

WatchMate Vision[®] Install Guide



vespermarine

Your WatchMate Vision® is a Class B AIS Transponder with a Color Touch Display and integrated NMEA 2000 and WiFi.

The WatchMate provides information to improve your situational awareness and assist in avoiding collisions at sea. Because it consumes very low power, it may be left turned on whenever your vessel is underway. It works by interpreting Universal Shipborne Automated Identification Systems (AIS) messages which are sent over VHF by transponders installed on other vessels. The AIS system uses two dedicated VHF channels designated for this purpose and with the installation of the WatchMate to receive these signals you can view AIS information. You can also distribute AIS information to other devices on board your vessel (e.g. chart plotters, laptops, smart phones) using NMEA 2000, USB and WiFi. In addition, your vessel data is transmitted to all other AIS-equipped vessels within range.

For more information on go to www.vespermarine.com/vision.

WHAT YOU NEED TO GET GOING

- WatchMate Vision
- Mounting Bracket
- 10 pin power/data cable
- AIS/VHF antenna
- MMSI number
- 2A fuse or circuit breaker

✓ = Item Included

OPTIONAL ACCESSORIES

- 1m USB cable (for configuration)
- Panel mount template, gasket and 4 screws (cut these to the required length)
- Waterproof 5m USB cable with locking security ring
- NMEA 2000 cable, T connector and network extension cable
- SP160 Antenna Splitter
- External GPS Antenna with 10m cable
- External alarm buzzer

Consider other equipment you may need to install this on your vessel e.g. additional cable, cable ties, mounting screws, wire strippers, screwdriver etc.

✓ = Item Included

CONNECTIONS

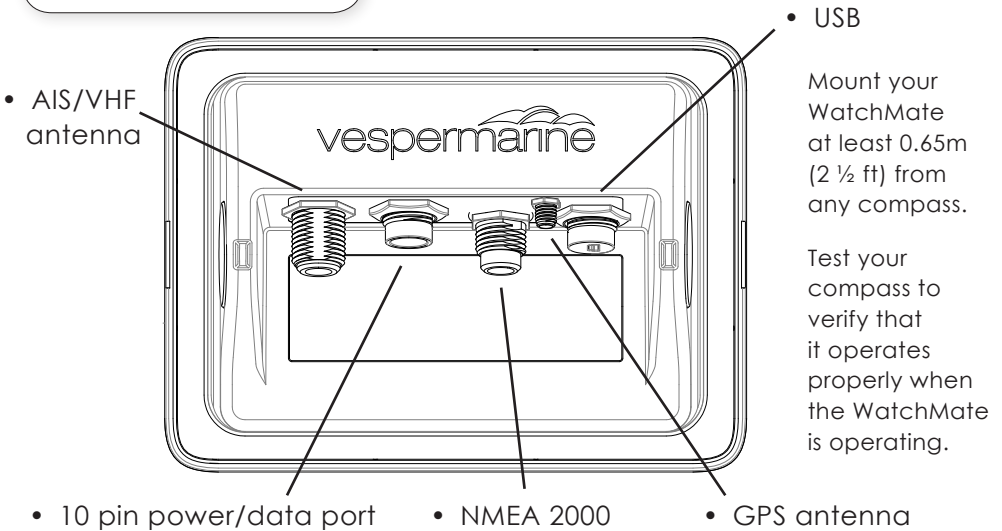

Mount your WatchMate at least 0.65m (2 ½ ft) from any compass.

Test your compass to verify that it operates properly when the WatchMate is operating.

When flush mounting, use the supplied template to carefully cut the holes. Always use the rubber gasket and install the screws from behind the panel.



CAUTION: Do not overtighten the flush mounting screws. Cut screws to the length required for your panel thickness.

VHF ANTENNA

- A dedicated VHF antenna or Vesper Marine AIS/VHF Antenna Splitter is required.
- Choose an omnidirectional VHF antenna designed for the marine band (156-162MHz) and ensure it is well tuned at the AIS end of the band (VSWR 2:1 or less at 162MHz). Avoid small helical "rubber duck" style antennas.
- Mount the antenna as high as possible (at least 2-3 metres (6-10 ft) above the water surface). It is not recommended to place the VHF antenna near a mast or other metal structures.



CAUTION: Install the antenna a minimum of 1m (4 ft) from any other VHF or HF antennas and not within the beam path of a radar. Inadequate separation may damage the device and void your warranty.



CAUTION: Never operate this device unless it is connected to a suitable VHF antenna or Vesper Marine AIS/VHF Antenna Splitter. The use of any other splitter may damage the device and void your warranty.



HINT: Use the WatchMate's VSWR meter to check your antenna system installation.

GPS ANTENNA

The WatchMate requires a GPS fix before it can transmit its position.

Internal

The WatchMate has a built-in GPS antenna.

- This antenna requires an unobstructed view of the sky.
- The antenna performance may be significantly reduced if the WatchMate is installed on, under, or near large metal structures.
- The antenna faces upwards and is located as shown:
- For faster fix times, turn the unit off using the menu option and keep power connected to the unit.

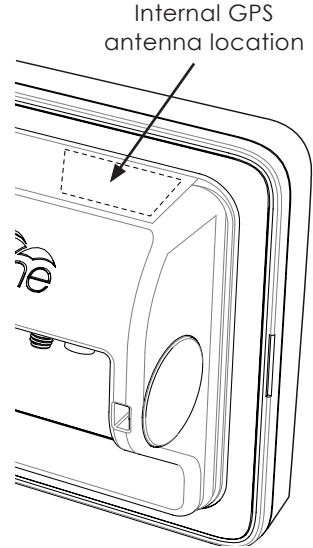

HINT: Use the My Position screen to view satellite signal strengths which will assist in determining the best location for the WatchMate or the external GPS antenna.

External (optional)

If you are mounting the WatchMate in a location which will not provide adequate GPS signal coverage, then you must install a dedicated GPS antenna.

- The GPS antenna should be situated so that it has an unobstructed view of the sky above.
- Do not place the GPS antenna near or in the path of radar or HF antennas.
- The antenna cable is terminated with a small SMA connector to facilitate easy routing through holes and openings. Do not cut the cable unless you have the proper tools to crimp a new connector. Make the connection to your AIS transponder last after antenna installation is complete.

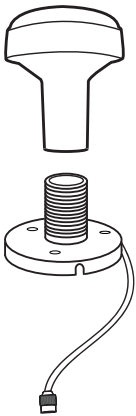

CAUTION: The Vesper Marine GPS antenna is designed specifically for use with the WatchMate Transponder. Performance cannot be assured unless you use a Vesper Marine GPS antenna. Use of a different antenna may damage the device and void your warranty.

NMEA 2000

The WatchMate can be connected to a NMEA 2000 network to enable AIS and GPS data to be sent to other NMEA 2000 devices. The WatchMate can also receive and make use of data sent from NMEA 2000 sensors.

- Supported NMEA sensors can be viewed on the My Instruments screen.
- Data Packets (PGN's) supported are defined below.
- A drop cable, T connection and network extension cable are required to connect the WatchMate to your NMEA 2000 network.

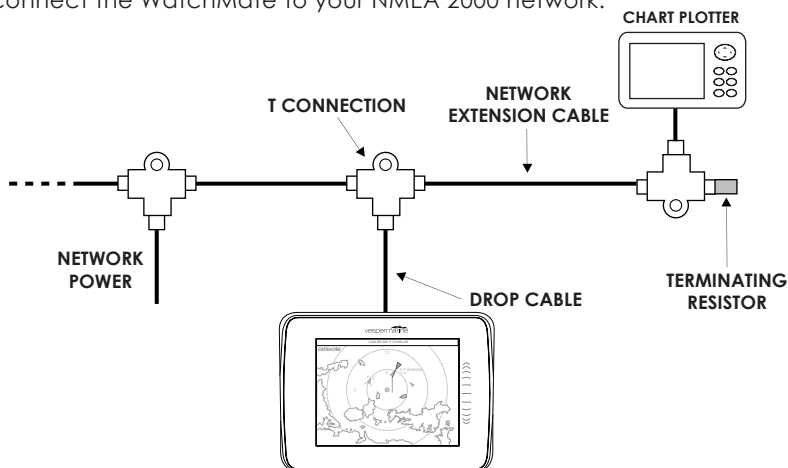

PGNs Received

Received PGN's are translated and output on the NMEA 0183, USB and WiFi ports. See www.vespermarine.com/vision for an up-to-date list.

PGN	DESCRIPTION	NMEA 0183 TRANSLATION
127250	Vessel Heading	HDG
128259	Speed	VHW
128267	Water Depth	DPT
128275	Distance Log	VLW
130306	Wind	MWD, MWV
130310, 130311 130312, 130316	Water Temperature	MTW

PGNs Sent

129025 Position (Rapid)

129026 COG & SOG (Rapid)

129029 GNSS Position

129540 GNSS Satellites

129038 AIS Class A Position

129039 AIS Class B Position

129040 AIS Class B Extended Position

129041 AIS Aids to Navigation

129794 AIS Class A Static Voyage

129798 AIS SAR Aircraft Position

129801 AIS Addressed Safety

129802 AIS Safety Related Broadcast

129809 AIS Class B "CS" Static, Part A

129810 AIS Class B "CS" Static, Part B

POWER AND DATA

A 2m (6 ½ft) cable with attached 10 pin connector is supplied for connecting the WatchMate to power, other devices over NMEA 0183, an external switch and external alarm. You may extend this cable as necessary.

- Check you have the VHF antenna connected before connecting to power.
- Fully engage the locking ring to ensure a watertight seal.

COLOR	DESCRIPTION
Red	DC positive (+) (12-24 volts). Always use a 2A fuse or circuit breaker. Do not connect directly to battery. If you must extend the power connections use high quality pre-tinned marine grade wire which is at least 16 AWG (1.5mm²) .
Black	DC negative (-)
Gray	NMEA 0183 out (+) A
Yellow	NMEA 0183 out (-) B
Green	NMEA 0183 in (+) A Received data is output on WiFi, USB & 0183
White	NMEA 0183 in (-) B
Brown	External switch may be used to activate anchor watch. Do not connect if not used.
Blue	External alarm (limited to 150mA)* Do not connect if not used.

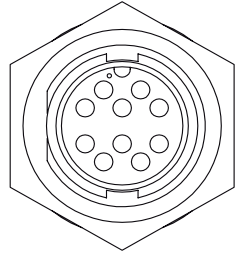

HINT: To turn ON the WatchMate simply touch the screen. Use the Menu to turn OFF.

HINT: Anchor Alarm may be armed and all alarms may be silenced using the WatchMate mobile apps.

(Do not connect orange or pink wire)

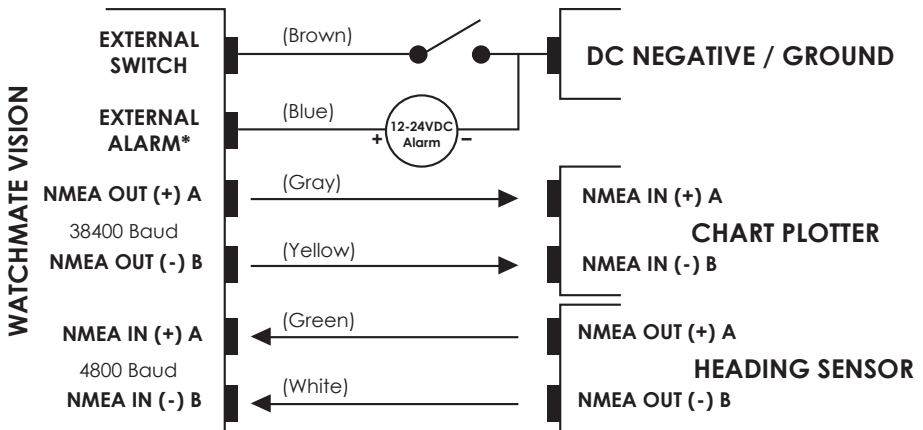

AIS PLOTTER

- Color and size of targets change depending on their alarm state.
- The target icon points in the direction of the target's heading. If heading data is not available it will use course over ground (COG). Target vectors always use COG.
- You must have a valid GPS fix for any targets to be shown on the AIS plotter.
- Go to www.vespermarine.com/vision for additional information.

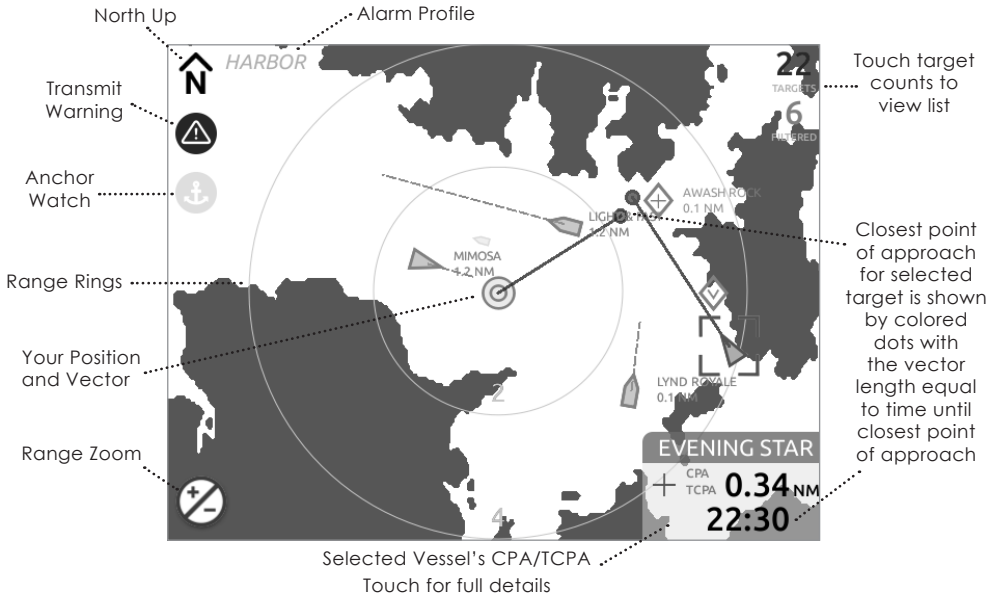

Icon Meanings

- Class B target.
- Class A target.
- An aid to navigation. A virtual aid to navigation.
- An AIS Man Overboard (AIS MOB) or search and rescue transponder (AIS SART).
- This symbol appears around a target to indicate it is the currently selected target.
- This symbol is overlaid over a target to indicate the target is "lost". No AIS data has been received from the target within the expected interval.
- Indicates your AIS data is not being transmitted. You can use the AIS Status screen to determine the reason.
- When used with a Vesper Marine AIS/VHF antenna splitter this symbol indicates the VHF radio is in-use and AIS transmissions are temporarily disabled.

WiFi

Configure your WatchMate WiFi from the WiFi settings menu.

Access Point Mode (default)

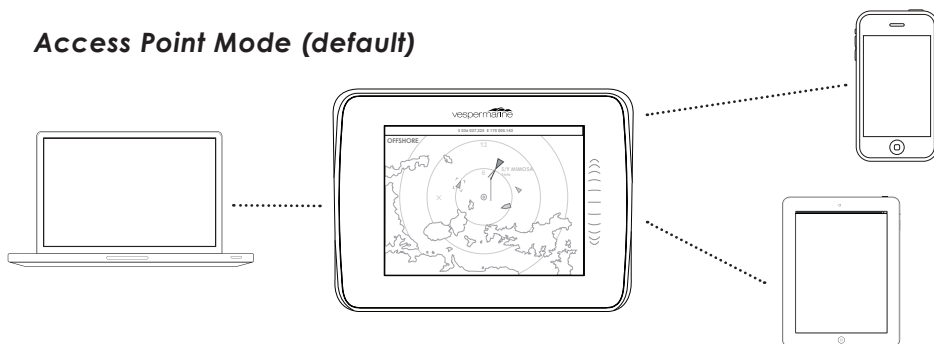

The WatchMate will control your onboard WiFi network for up to 5 devices.

You can connect to the WatchMate using:

- Network (SSID): **VesperXB-xxxxxx (serial number)**
- Password: **WatchMate**

We recommend that you change your password straight away. You can always access the password in the WiFi settings.

The default IP address that mobile apps may need is **192.168.15.1 (Port 39150)**.

Client Mode

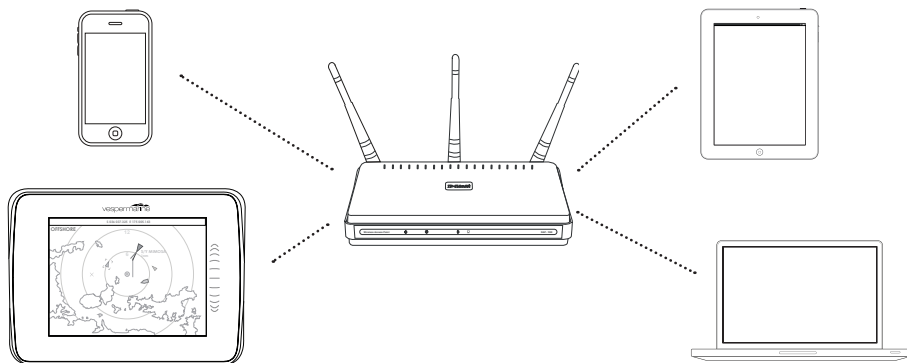

The WatchMate can also join an existing network. It can do this in either DHCP mode (default) or you can set a static IP address. To prevent the address from automatically changing we recommend that you use a static IP address.

CONFIGURATION

- Before the WatchMate can transmit your position you must configure your vessel details and enter a valid MMSI number. Your MMSI may have been entered already by your dealer. **You must have an assigned MMSI and Call Sign for your vessel.** If you do not have an assigned MMSI, contact the relevant authority in your country.
- You can configure your WatchMate from the menu, using the WatchMate App or the vmAIS PC software. The WatchMate App and vmAIS are available for download from www.vespermarine.com/vision.
- **Once you save the MMSI number you cannot change it.** If you need to change the MMSI, please contact an authorized dealer or Vesper Marine.
- To configure your vessel details use the menu to select the AIS Settings as shown below:

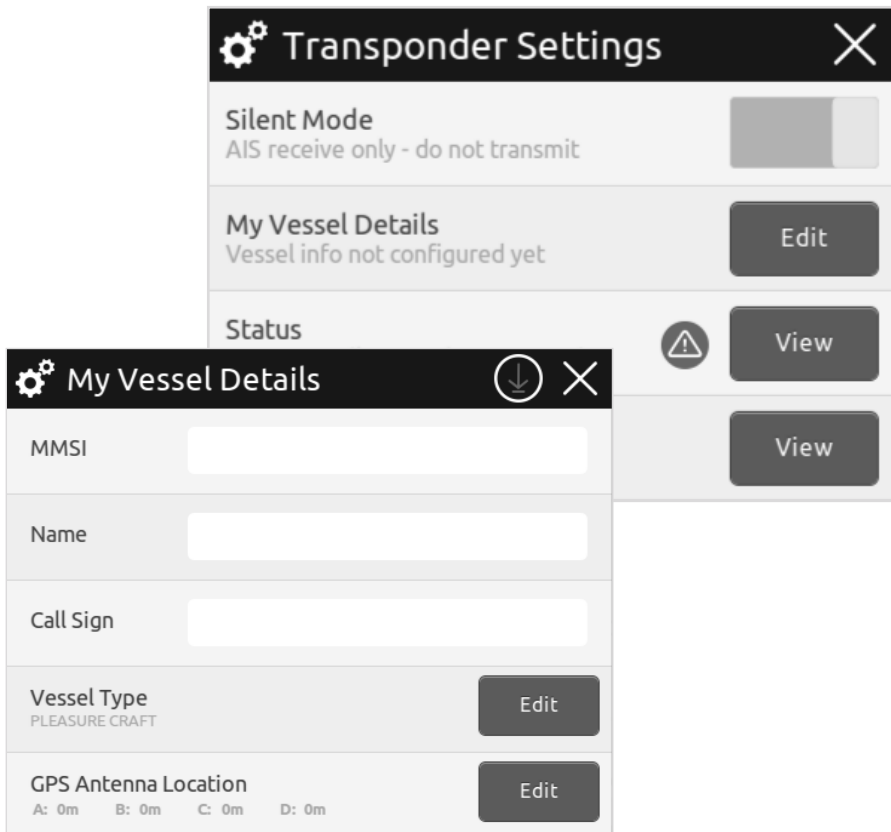

Transponder Settings

Silent Mode
AIS receive only - do not transmit

My Vessel Details
Vessel info not configured yet

Status

View

View

My Vessel Details

MMSI

Name

Call Sign

Vessel Type
PLEASURE CRAFT

GPS Antenna Location
A: 0m B: 0m C: 0m D: 0m

- With vmAIS you can connect to the WatchMate using either the USB COM port or over WiFi by entering the IP address (192.168.15.1 default).
- Click the **Connect** button and enter your vessel details.
- When all the information is correct, click on the **Save Data** button.
- You can also change your WiFi settings, view your GPS signal strength, transponder status and VSWR level using vmAIS.

The screenshot shows the WatchMate configuration interface. At the top, there are fields for 'Com Port' (set to COM10), 'IP Address', and 'Port', along with a 'Disconnect' button. Below this is a section for vessel identification: 'Model: XDB000', 'Version: 5.06 (1.03.4799)', 'Serial Number: KW74131', and 'Revision: 4993M'. The main area is titled 'Configure Vessel Data' and includes tabs for 'WiFi', 'NMEA2000', 'Status', 'GPS', 'Firmware Update', and 'Serial Data'. Under 'Configure Vessel Data', there are fields for 'MMSI', 'Name', and 'Call Sign', with an 'Info...' button next to MMSI. A 'Type' dropdown menu is set to 'Pleasure craft (primary propulsion is engine)'. Below this is a diagram of a boat with a 'GPS ANTENNA' marked. Dimensions are indicated: 'A' (width), 'B' (length), 'D' (height from centerline), and 'C' (height from deck). A 'Units' section has radio buttons for 'Metres' (selected) and 'Feet *'. A 'Save Data' button is at the bottom. A note at the very bottom states: '* Data is always stored in whole metres. Therefore not all dimensions in feet can be represented.'

YOU'RE FINISHED!

If you have a GPS position and there is no warning symbol the WatchMate is transmitting your position and is successfully installed! Your position will be transmitted every 3 minutes when your speed is under 2 knots or every 30 seconds otherwise. Your vessel information (e.g. name, callsign, etc) is transmitted every 6 minutes. If the warning symbol is still visible, touch it to display the reason. See the troubleshooting section for the probable cause.

GOT A QUESTION?

Visit www.vespermarine.com/vision for comprehensive answers to frequently asked questions, the user manual, technical support, downloads, local dealer contacts and more...

REGISTER YOUR WATCHMATE

Vesper Marine releases downloadable updates from time to time. These updates often add new features. To be notified when a new update is available please register your WatchMate at www.vespermarine.com/register.

USB

- When you connect the WatchMate to your PC or Mac using USB, it will automatically create a COM port (see configuration section). This COM port may then be used with the vmAIS utility or 3rd party navigation software. Download vmAIS from **www.vespermarine.com/vision**.
- The first time you plug it in, most operating systems will automatically install the necessary drivers.
- If a COM port is not created the first time you plug it in, you may need to install the drivers manually. Download the USB drivers from **www.vespermarine.com/vision**.

TROUBLESHOOTING

The  symbol indicates your AIS data is not being transmitted. It is located at the top left of the screen, touch it to reveal the AIS Transponder Status.

STATUS	DESCRIPTION
MMSI CONFIGURED	You must have a valid MMSI programmed before you can transmit your position (see configuration section).
SILENT MODE IS OFF	Silent mode is on. If this is not intentional check silent mode is switched off in AIS settings.
STARTUP COMPLETE	Before the WatchMate can transmit it needs 1 minute to initialize.
GPS POSITION FIX	The WatchMate requires a GPS fix before it can transmit its position. This may take a few minutes. If it is taking a long time check your GPS antenna installation (see GPS antenna section) and GPS signal strength on the My Position screen.
POSITION REPORT SENT	This may happen from time to time in very busy areas with lots of AIS traffic. This is normal behaviour for a Class B AIS device.
VSWR OK	Check your antenna installation. Use the VSWR meter in advanced AIS settings. A poorly tuned antenna, bad cabling or connections are typical reasons for a high VSWR. Your WatchMate will continue to operate normally but transmit performance will degrade.

TECH SPECS

Size	172mm wide x 130mm high x 60mm depth (6 7/8" x 5 1/8" x 2 3/8")
LCD Touch panel	145mm (5 11/16"), VGA Color TFT, Resistive Touch
Power supply	10-32 VDC 2A max, 6W nominal
Environmental	Waterproof (IPx7)
Operating temperature	-25°C to +55°C (-13°F to 131°F)
Storage temperature	-25°C to +80°C (-13°F to 176°F)
Serial data	1 USB port (isolated), 1 NMEA input (isolated RS422), 1 NMEA output (non-isolated RS422)
Data port impedance	NMEA input: 96k ohm, NMEA output: 28 ohm
NMEA output	RMC, GSV, GSA, GGA, GLL, VTG, VDO, VDM, TXT, DSC, HDG, VHW, DPT, VLW, MWD, MWV, MTW, APB, BOD, BWC, BWR, BWW, XTE, WPL
NMEA input (optional)	HDG, HDM, HDT (These are processed, but are not required. Other sentences are not processed but all valid NMEA sentences are output on NMEA 0183, WiFi and USB)
Number of receivers	2 AIS, 1 DSC (timeshared)
Number of transmitters	1 AIS
Receive frequency range	156.025 – 162.025 MHz
Transmit frequency range	161.500 – 162.025 MHz
AIS sensitivity	-113 dBm < 20% PER
Power output	33 dBm (2W)
GPS sensitivity	-159dBm tracking & navigation -142dBm acquisition
GPS SBAS support	WAAS, EGNOS, MSAS, GAGAN
External alarm maximum	150 mA @ VDC
Power/data connector	10 pin circular
USB connector	Mini USB (USB 2.0)
GPS antenna connector	SMA
VHF antenna connector	SO-239
VHF antenna required	50 ohm, max 2:1 VSWR @ 162MHz. PL-259 connector.
NMEA 2000 connector	NMEA 2000 Micro-C male
Firmware version	5.16
Wireless	802.11 b/g in Access Point or Client Mode
Wireless security	WPA2 Personal (Also none and WPA in Client Mode)

WARNINGS

This AIS Transponder works in conjunction with other vessels and systems, such as other AIS transponders and GPS devices. The accuracy of this device and the AIS system can be affected by many factors, including equipment failure or defects, environmental conditions and incorrect installation, handling or use. Vesper Marine does not warrant that this product is error-free. It is the user's responsibility to exercise common prudence and navigational judgment. This device should not be relied upon as a substitute for such prudence and judgment. Always maintain a permanent watch so that you can respond to situations as they develop. The prudent mariner will not rely on a single aid to navigation. The user should verify the information obtained from this AIS Transponder is in accordance with expected situations and conditions. The information is not guaranteed to be accurate or reliable and this AIS Transponder is not a substitute for proper seamanship. Vesper Marine Limited cannot be held liable for any injury, damage or loss, caused by, during, or because of the installation, use or inability to use this device. This AIS Transponder is to be installed and used entirely at your own risk. By installing and/or using this AIS Transponder you fully accept this risk and agree to hold Vesper Marine Limited harmless. If you do not agree to accept all risk, return this product unused in its original factory condition to your dealer for a full refund.

Intended Use

This product is intended to be used on leisure or commercial vessels (excluding IMO/SOLAS class). Vesper Marine has designed and manufactured this product to be used only aboard vessels.

Warranty Void

Do not disassemble the unit or remove the screws which hold it together. The unit is sealed and disassembly will void the warranty.

FCC Warning:

This device complies with Part 15 of the FCC Rules. Operation is subject to the following two conditions: (1) this device may not cause harmful interference and (2) this device must accept any interference received, including interference that may cause undesired operation.

Industry Canada Warning:

This device complies with Industry Canada license-exempt RSS standard(s). Operation is subject to the following two conditions: (1) this device may not cause interference, and (2) this device must accept any interference, including interference that may cause undesired operation of the device.

This device complies with RSS-310 of Industry Canada. Operation is subject to the condition that this device does not cause harmful interference.

To satisfy RF exposure requirements for mobile transmitting devices, a separation distance of 1 metre or more should be maintained between the antenna of this device and persons during device operation. To ensure compliance, operations at closer than this distance is not recommended.

The antenna used for this transmitter must not be co-located in conjunction with any other antenna or transmitter.

This device has been designed to operate with an antenna having a maximum gain of 3dBi. Antennas having a gain greater than 3dBi are strictly prohibited for use with this device. The required antenna impedance is 50 ohms.

To reduce potential radio interference to other users, the antenna type and its gain should be chosen that the equivalent isotropically radiated power (EIRP) is not more than that required for successful communication.

Pour satisfaire aux exigences d'exposition aux fréquences radio pour les appareils mobiles de transmission, une distance de 1 mètre ou plus doit être maintenue entre l'antenne de ce dispositif et les personnes pendant son fonctionnement. Pour assurer la sécurité, les opérations plus près de cette distance ne sont pas recommandées.

L'antenne utilisée pour ce transmetteur ne doit pas être co-localisée avec toute autre antenne ou transmetteur.

Ce dispositif a été conçu pour fonctionner avec une antenne ayant un gain maximal de 3dBi. Les antennes ayant un gain supérieur à 3dBi sont strictement interdites pour une utilisation avec cet appareil. L'impédance d'antenne requise est de 50 ohms.

Pour réduire le risque d'interférence aux autres utilisateurs, le type d'antenne et son gain doivent être choisis pour que la puissance isotrope rayonnée équivalente (PIRE) ne soit pas supérieure à celle requise pour une communication réussie.

MMSI Programming Warning

IMPORTANT: In most countries, the operation of an AIS unit is included under the vessel's marine VHF license provisions and the vessel on which this device is to be installed may be required to possess a current VHF radiotelephone license which lists the AIS system and the vessel Call Sign and MMSI number.

An MMSI number is required in order for this device to operate as a transmitter.

Please contact the relevant authority in your country for more information.

For Customers in the USA

This device must be programmed with data corresponding to the vessel on which it will be installed. Programming must be carried out by a Vesper Marine dealer. The included instructions contain information on how to verify the correct programming.

WARNING: It is a violation of the rules of the Federal Communications Commission to input an MMSI that has not been properly assigned to the end user, or to otherwise input any inaccurate data in this device.

RF Emissions Warnings



CAUTION: This device generates and radiates electromagnetic energy. This device must be installed and operated according to the instructions contained in this manual. Failure to do so may result in product malfunction and/or exposure to potentially harmful levels of radio frequency radiation. Changes or modifications to the unit not expressly approved by Vesper Marine Ltd will void the user's authority to operate this equipment.



CAUTION: The system has a Maximum Permissible Exposure (MPE) radius of 1m from the antenna. This has been determined assuming the maximum power of the transmitter and using a standard half-wave monopole VHF antenna with a maximum gain of 3dBi and termination impedance of 50 ohms.

When installing the antenna and operating the equipment consider the following:

- The antenna should be mounted as high above deck as possible.
- Higher gain VHF antennas will require a larger MPE radius.
- Do not operate the unit when anyone is within the MPE radius of the antenna.
- The antenna should not be collocated or operated in conjunction with any other transmitting antenna.

WARRANTY

Your Vesper Marine AIS transponder is warranted, when properly installed and used, to be free from defects in materials or workmanship for two years, from the date the product was purchased by the first retail customer. This warranty applies to the original retail purchaser only and is not transferable. This warranty only applies to products purchased from Vesper Marine or from an authorized Vesper Marine reseller. Within this period, Vesper Marine will, at its sole option, repair or replace any components which fail in normal use. Repairs or replacement will be made at no charge for parts or labor, provided that the customer shall be responsible for any transportation costs. This warranty does not cover failures due to abuse, misuse, accident, improper installation, unauthorized alterations or repairs, shipping damage, wear and tear, or corrosion.

This warranty will not apply if the product's external housing has been opened, the serial number or other labels have been removed or altered, or the specified input voltage has been exceeded. This warranty will not apply if the product has been operated with an incompatible GPS antenna or without a suitable VHF antenna, where applicable to the product.

Vesper Marine retains the exclusive right to repair or replace the unit at its sole discretion. In the event Vesper Marine chooses to replace the unit it may be replaced with a factory reconditioned unit or a new unit at its sole discretion. Where a replacement is provided the original product becomes the property of Vesper Marine and the warranty will remain from the original purchase date.

THE WARRANTIES AND REMEDIES CONTAINED HEREIN ARE EXCLUSIVE AND IN LIEU OF ALL OTHER WARRANTIES, WHETHER EXPRESS, IMPLIED OR STATUTORY, INCLUDING ANY LIABILITY ARISING UNDER ANY WARRANTY OF MERCHANTABILITY OR FITNESS FOR A PARTICULAR PURPOSE, STATUTORY OR OTHERWISE. THIS WARRANTY GIVES YOU SPECIFIC LEGAL RIGHTS, WHICH MAY VARY FROM STATE TO STATE.

IN NO EVENT SHALL VESPER MARINE BE LIABLE FOR ANY INCIDENTAL, SPECIAL, INDIRECT, OR CONSEQUENTIAL DAMAGES, WHETHER RESULTING FROM THE USE, MISUSE OR INABILITY TO USE THE PRODUCT OR FROM DEFECTS IN THE PRODUCT. SOME STATES DO NOT ALLOW THE EXCLUSION OF INCIDENTAL OR CONSEQUENTIAL DAMAGES, SO THE ABOVE LIMITATIONS MAY NOT APPLY TO YOU.

Vesper Marine retains the exclusive right to repair or replace the product or offer a full refund of the purchase price at its sole discretion. SUCH REMEDY SHALL BE YOUR SOLE AND EXCLUSIVE REMEDY.

*These warranty terms and conditions are provided as a summary and the specific terms and conditions of your warranty may vary by region. Please see www.vespermarine.com/vision for details of the warranty terms and conditions specific to your region.

Vesper Marine declares that this AIS Class B transponder is in compliance with Directive 2014/53/EU.

The full text of the EU Declaration of Conformity is available at the following internet address: www.vespermarine.com/compliance

This product is for use worldwide, including the following countries:

AT	BE	BG	CH	CY	CZ	DE	DK	EE	ES
FI	FR	GR	HU	IE	IS	IT	LT	LU	LV
MT	NO	NL	PL	PT	RO	SE	SI	SK	UK

This device is also approved for use in the United States, Canada, Australia and New Zealand.



Electronic Waste Recycling

Various regional and national regulations exist regarding the recycling of certain electronics.

Please consult your local authorities or contact Vesper Marine for recycling information.





Phone +64 9 950 4848 | Email info@vespermarine.com

Fax +64 9 950 4085 | Web www.vespermarine.com

Follow us on Facebook | www.facebook.com/vespermarine

Copyright © 2016, Vesper Marine Ltd.

AIS WatchMate, WatchMate Vision and WatchMate Wheel are trademarks of Vesper Marine Ltd.
All other products are trademarks or registered trademarks of their respective owners.

Unless otherwise indicated, all documentation and operating software contained within this product
or distributed with this product is copyrighted by Vesper Marine Ltd. All rights are reserved.

Portions of this product may use software licensed under open source license agreements.
Source code for the applicable software is available upon request from Vesper Marine Ltd.

WatchMate Vision 1610

Member of:

