

HEHR

POWER SYSTEMS

POWERLINE

HEAVY-DUTY ALTERNATORS

SERIES 23 / 24 ALTERNATOR

TROUBLE SHOOTING GUIDE

A DIVISION OF HEHR INTERNATIONAL INC.
4616 Fairlane Avenue, Fort Worth, Texas 76119
(817) 535-0284 • FAX (817) 531-2755
E-MAIL: powersales@hehrintl.com

OR VISIT OUR WEBSITE AT:
www.hehrintl.com

AN ISO 9001:2000 COMPANY



INDEX

- Page 1.** Configuration Alternators, Regulators and Wiring Harness
- Page 2.** On Vehicle Trouble Shooting Guide
- Page 3.** Alternator Electrical Condition
- Page 4.** 23/24 Series Terminal Identification
- Page 5 thru 7.** Regulator Identification and Pin Function
- Page 8 thru 9.** 23 Series Alternator Terminal Identification
- Page 10 thru 12.** 24 Series Alternator Terminal Identification
- Page 13.** External Rectifier Pac Terminal Identification
- Page 14.** Isolator Terminal Identification and Terminal Connections
- Page 15 thru 20.** 23 Series Alternator to Regulator Connections
- Page 21 thru 29.** 24 Series Alternator to Regulator Connections
- Page 30 thru 32.** Alternator and Regulator Voltage Test, 23/24 Series Alternators
- Page 33.** How to Full Field 23/24 Series Alternators
- Page 34.** How to Test for AMP Load
- Page 35.** 24 Series External Rectified Alternator Test
- Page 36.** External Rectifier Pac Trouble Shooting
- Page 37.** Bench Test Procedures
- Page 38.** Isolator Test
- Page 39.** Finding Pulley Ratio
- Page 40.** Recommend Battery Cable Size
- Page 41 thru 44.** 23 Series Power Curves
- Page 45 thru 48.** 24 Series Power Curves
- Page 49.** Miscellaneous Alternator Information
- Page 50.** 24 Series 24-Volt Voltage Test
- Page 51.** 23 Series Enclosed Brush Model Gasket Installation

Wiring Harness and Regulator

CONFIGURATION

All Models 23 Series Standard Alternators

All Models 23 Series Marine Enclosed Brush Alternators

100, 120 and 150 Amp 12-Volt Models

All Models 24 Series Standard Alternators

All Models 24 Series Insulated Field Alternators

All Models 24 Series External Rectified Alternators

160, 190 and 220 Amp 12-Volt Models

100 Amp 24-Volt Models

Wiring Harness Color and Configuration

#1 (S2)	Auxiliary Sense Lead - Red w/Yellow strip
#2 (F)	Field Lead - Blue
#3 (I)	Ignition Lead - Brown or Green w/ Red strip
#4 (S1)	Sense Main Battery Lead - Red w/ White strip
#5 (Grd)	Ground Lead - Black
#6 (S)	Stator Lead - White
#7 (A)	Current Power Lead - Red

10-170 and 10-172
L.E.D. Configuration

Green LED on Indicates the A Terminal has battery power

Orange LED on Indicates Field is on and supplying field current

Yellow LED on Indicates Stator output is present Alternator is working

Red LED on Indicates Overload condition, Low voltage condition.

ON VEHICLE TROUBLE SHOOTING GUIDE PRELIMINARY PROCEDURES

***POWERLINE* 23 and 24 SERIES ALTERNATORS ALL MODELS WITH EXTERNAL REGULATORS**

- 1) CHECK ALTERNATOR DRIVE BELT (S) AND BELT TENSION.
- 2) CHECK ALTERNATOR POSITIVE AND NEGATIVE CABLE CONNECTIONS.
- 3) CHECK FOR PROPERLY SIZED CABLES FROM ALTERNATOR TO BATTERY (S), BOTH POSITIVE AND NEGATIVE. **0 CABLE MINIMUM.**
- 4) CHECK NEGATIVE CABLE CONNECTIONS TO FRAME RAILS WHEN USED FOR GROUND CIRCUIT, FOR CLEAN TIGHT CONNECTIONS. **0 CABLE MINIMUM.**
- 5) CHECK CABLE CONNECTIONS **ON** BATTERY FOR CLEAN TIGHT CONNECTIONS.
- 6) CHECK BATTERY (S) CONDITION, 12.6 VOLT – 100%, 12.4 VOLT – 75%, 12.2 VOLT – 50% STATE OF CHARGE. TRUE BATTERY VOLTAGE IS OBTAINED **AFTER** REMOVING ANY SURFACE CHARGE FROM BATTERIES. IF BATTERY VOLTAGE IS **LESS THAN 12.4 VOLTS**, REPLACE OR RECHARGE BATTERIES AND RETEST. IF BATTERY VOLTAGE IS **EQUAL TO OR HIGHER THAN 12.4 VOLTS**, CONTINUE TO TEST.
- 7) IDENTIFY MODEL OF ALTERNATOR.
- 8) IDENTIFY MODEL OF REGULATOR.
- 9) DETERMINE IF VEHICLE IS ISOLATOR EQUIPPED.
- 10) LOCATE IN MANUAL THE CORRECT TERMINAL REFERENCE DRAWING FOR THE ALTERNATOR ON VEHICLE.
- 11) LOCATE IN MANUAL THE CORRECT TERMINAL CONNECTION REFERENCE DRAWING FOR THE ALTERNATOR AND REGULATOR ON VEHICLE.

ALTERNATOR ELECTRICAL CONDITION (POSSIBLE CAUSES)

LOW VOLTAGE OUTPUT

- 1) LOOSE DRIVE BELTS (S)
- 2) WIRING PROBLEM ON POSITIVE OR NEGATIVE OR BOTH CABLES. POOR CONNECTIONS OR IMPROPERLY SIZED WIRE FOR THE ALTERNATOR SIZE OR LENGTH OF CABLES.
- 3) CURRENT LOAD ON SYSTEMS GREATER THAN ALTERNATOR CAN PRODUCE AT THAT SPEED
- 4) WRONG PULLEY RATIO (P.R.) FOR APPLICATIONS: THE O.D. OF CRANKSHAFT PULLEY DIVIDED BY THE O.D. OF ALTERNATOR PULLEY DETERMINES P.R. MOST HEAVY DUTY APPLICATIONS REQUIRE A P.R. OF 2.5 OR HIGHER.
- 5) LOW REGULATOR SET POINT
- 6) DEFECTIVE REGULATOR
- 7) DEFECTIVE ALTERNATOR

HIGH VOLTAGE OUTPUT

- 1) HIGH REGULATOR SET POINT
- 2) S1 SENSE TERMINAL CONNECTED AT WRONG POINT, BAD CONNECTION, OR NOT SENSING TRUE BATTERY VOLTAGE.
- 3) DEFECTIVE ISOLATOR (IF IN SYSTEM)
- 4) DEFECTIVE REGULATOR, OR REGULATOR ADJUSTMENT SET TOO HIGH.
- 5) RADIO FREQUENCY INTERFERENCE (RFI). IF HIGH VOLTAGE IS AN INTERMITTENT CONDITION CAN YOU TIE IT TO USING A POWERFUL RADIO? IF YES, CALL 1-800-443-9394 FOR TECHNICAL ASSISTANCE.

NO VOLTAGE OUTPUT

- 1) NO DRIVE BELT
- 2) NO VOLTAGE ON "A" TERMINAL (BLOWN FUSE ON "A" LEAD) (10-130 REGULATOR BLOWN FUSE ON REGULATOR)
- 3) NO VOLTAGE AT IGNITION TERMINAL
- 4) NO GROUND CABLE ON ISOLATED GROUND SYSTEM
- 5) FIELD CONNECTION NOT CORRECT ON INSULATED FIELD MODELS
- 6) DEFECTIVE REGULATOR: DO ON VEHICLE VOLTAGE TESTS. (See Pages 30-32)
- 7) DEFECTIVE ALTERNATOR: MOMENTARILY FULL FIELDING OF ALTERNATOR WILL DETERMINE IF IT IS GOOD OR BAD. (See Page 33)
- 8) REGULATOR GROUND LEAD HAS A BAD CONNECTION
- 9) S1 OR S2 NO VOLTAGE: CHECK FOR BLOWN FUSE OR BAD CONNECTION
- 10) F TERMINAL NO VOLTAGE: CHECK FOR BLOWN FUSE IN "A" TERMINAL LEAD

TERMINAL IDENTIFICATION

23, 24 Series Alternator and External Rectifier Assembly

TERMINAL

- A. Positive Alternator output Terminal
- B. Negative Alternator output Terminal of Ground connections
- C. Field Positive Terminal
- D. Stator of Relay Terminal (Tachometer connection)
- E. A.C. Terminal Alternator External Rectified
- F. A.C. Terminal Alternator External Rectified
- G. A.C. Terminal Alternator External Rectified
- H. Battery Positive Terminal
- I. Battery Negative Terminal
- J. A.C. Terminal External Rectifier Assembly
- K. A.C. Terminal External Rectifier Assembly
- L. A.C. Terminal External Rectifier Assembly
- M. Positive Terminal External Rectifier Assembly
- N. Negative Terminal External Rectifier Assembly
- O. Field Negative Terminal

REGULATOR TERMINAL IDENTIFICATION

- 1. (S2) Remote sense for Auxiliary Battery (Use only with isolator in system)
- 2. (F) Regulator output (Drives field winding)
- 3. (I) Turns Regulator on (3,4,6 or 7 wire hook up)
- 4. (S1) Remote sense for the main battery
- 5. (Grd) Circuit grounding for the regulator
- 6. (S) 3 or 6 wire hook up turns regulator on
(S) 4 or 7 wire hook up turn charge light off
- 7. (A) Power supply to regulator and field

ISOLATOR TERMINAL IDENTIFICATION

- P. B1 Main Battery Connection
- Q. A Alternator Connection
- R. B2 Auxiliary Battery Connection
- S. Auxiliary Battery Positive Post
- T. Auxiliary Battery Negative Post

REGULATOR IDENTIFICATION

(MODEL 10-11)

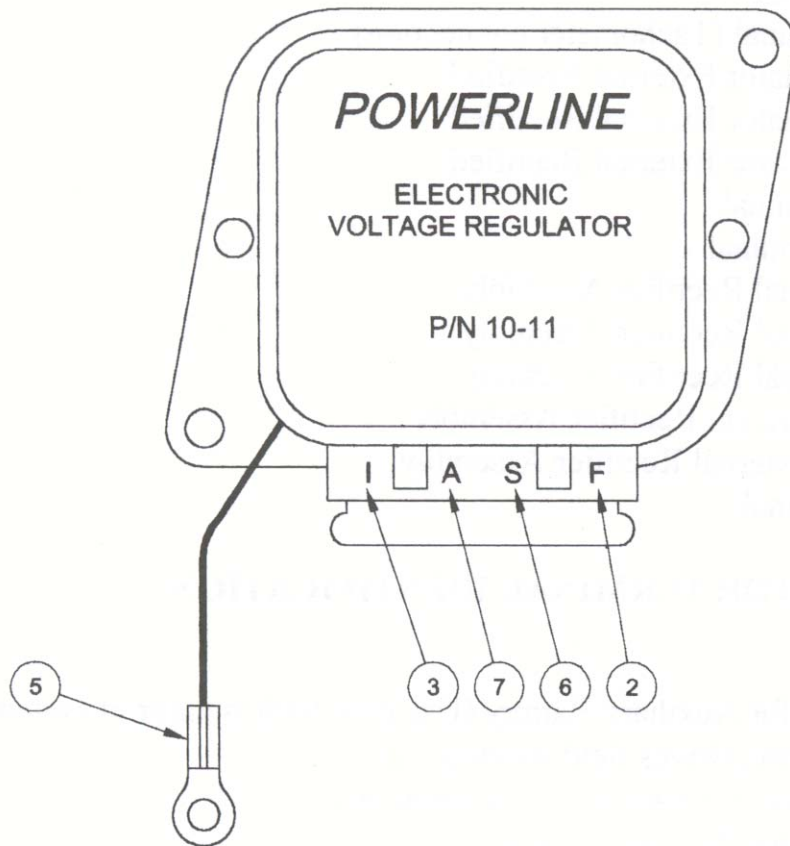

PIN FUNCTION

- | | | |
|----|------|--|
| 2. | F | REGULATOR OUTPUT (DRIVES FIELD WINDING OF ALTERNATOR) |
| 3. | I | TURNS REGULATOR ON (4 WIRE HOOK-UP) |
| 5. | CASE | CIRCUIT GROUND FOR REGULATOR |
| 6. | S | 3 WIRE HOOK-UP (TURNS REGULATOR ON)
4 WIRE HOOK-UP (TURNS WARNING LIGHT OFF WHEN THE ALTERNATOR IS WORKING) |
| 7. | A | POWER SUPPLY AND VOLTAGE SENSE LEAD FOR REGULATOR (ALL MODELS) |

REGULATOR IDENTIFICATION

(MODEL 10-129 & 10-130)

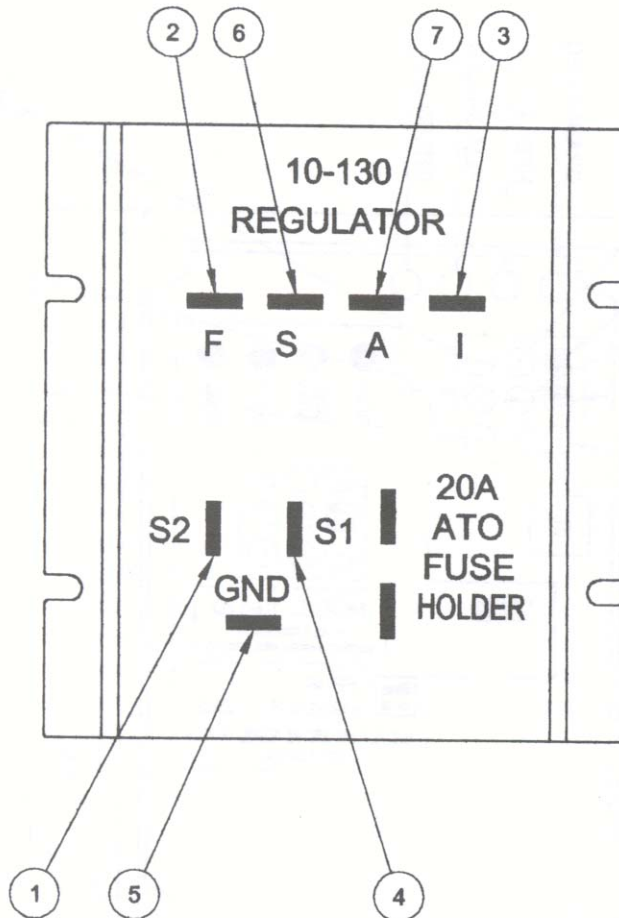

PIN FUNCTION

1. S2 REMOTE SENSE FOR AUXILIARY BATTERY
2. F REGULATOR OUTPUT (DRIVES FIELD WINDING OF ALTERNATOR)
3. I TURNS REGULATOR ON (4 WIRE HOOK-UP)
4. S1 REMOTE SENSE FOR THE MAIN BATTERY
5. GND CIRCUIT GROUND FOR THE REGULATOR
6. S 6 WIRE HOOK-UP (TURNS THE REGULATOR ON)
7 WIRE HOOK-UP (TURNS THE WARNING LIGHT OFF WHEN THE ALTERNATOR IS WORKING)
7. A POWER SUPPLY TO THE REGULATOR AND FIELD

REGULATOR IDENTIFICATION

(MODEL 10-170 & 10-172)

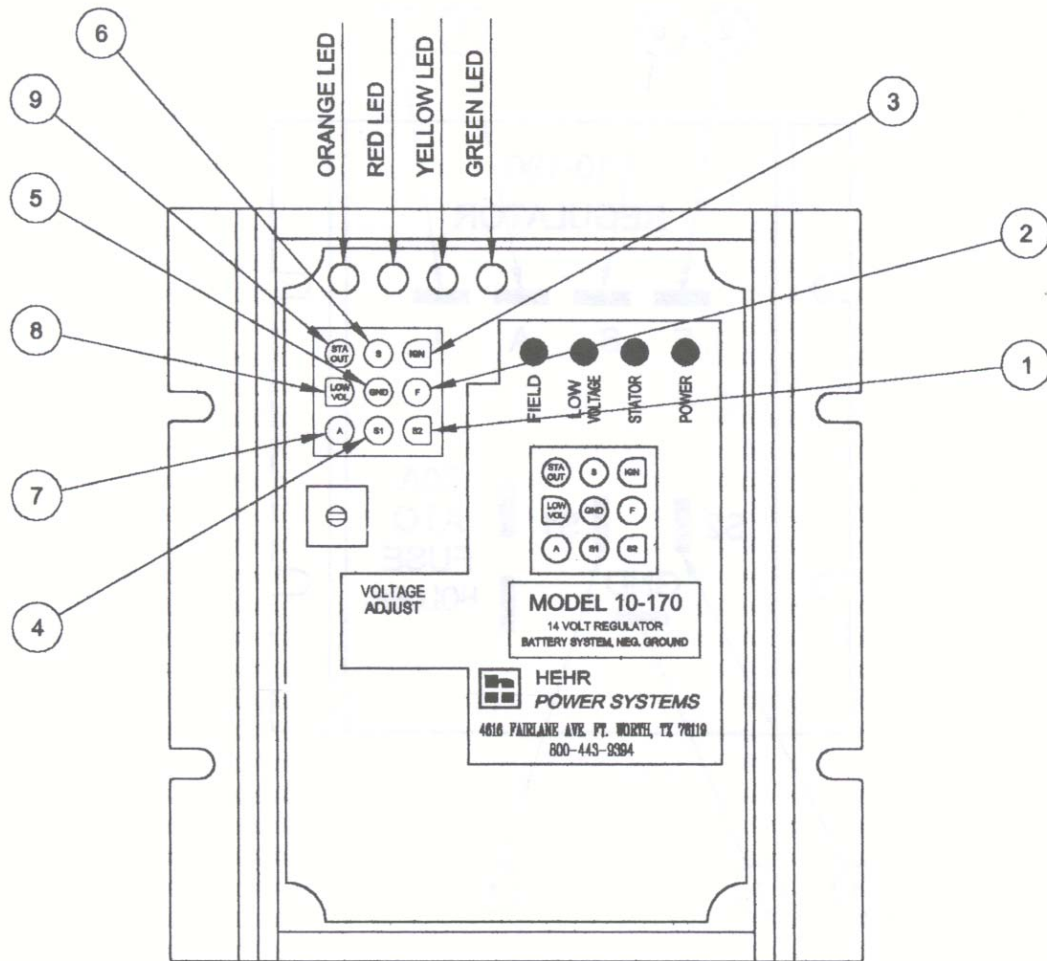

PIN IDENTIFICATION

- | | | |
|----|-----|---|
| 1. | S2 | REMOTE SENSE FOR AUXILIARY BATTERY |
| 2. | F | REGULATOR OUTPUT (DRIVES FIELD WINDING) |
| 3. | I | TURNS REGULATOR ON (4 WIRE HOOK-UP) |
| 4. | S1 | REMOTE SENSE FOR THE MAIN BATTERY |
| 5. | GND | CIRCUIT GROUND FOR THE REGULATOR |
| 6. | S | 7 WIRE HOOK-UP (TURNS WARNING LIGHT OFF WHEN ALTERNATOR IS WORKING) |
| 7. | A | POWER SUPPLY TO THE REGULATOR AND FIELD |
| 8. | | LOW VOLTAGE (REMOTE LED) |
| 9. | | STATOR ON (REMOTE LED) |

SERIES 23

(12 VOLT, 100, 120 & 150 AMP)

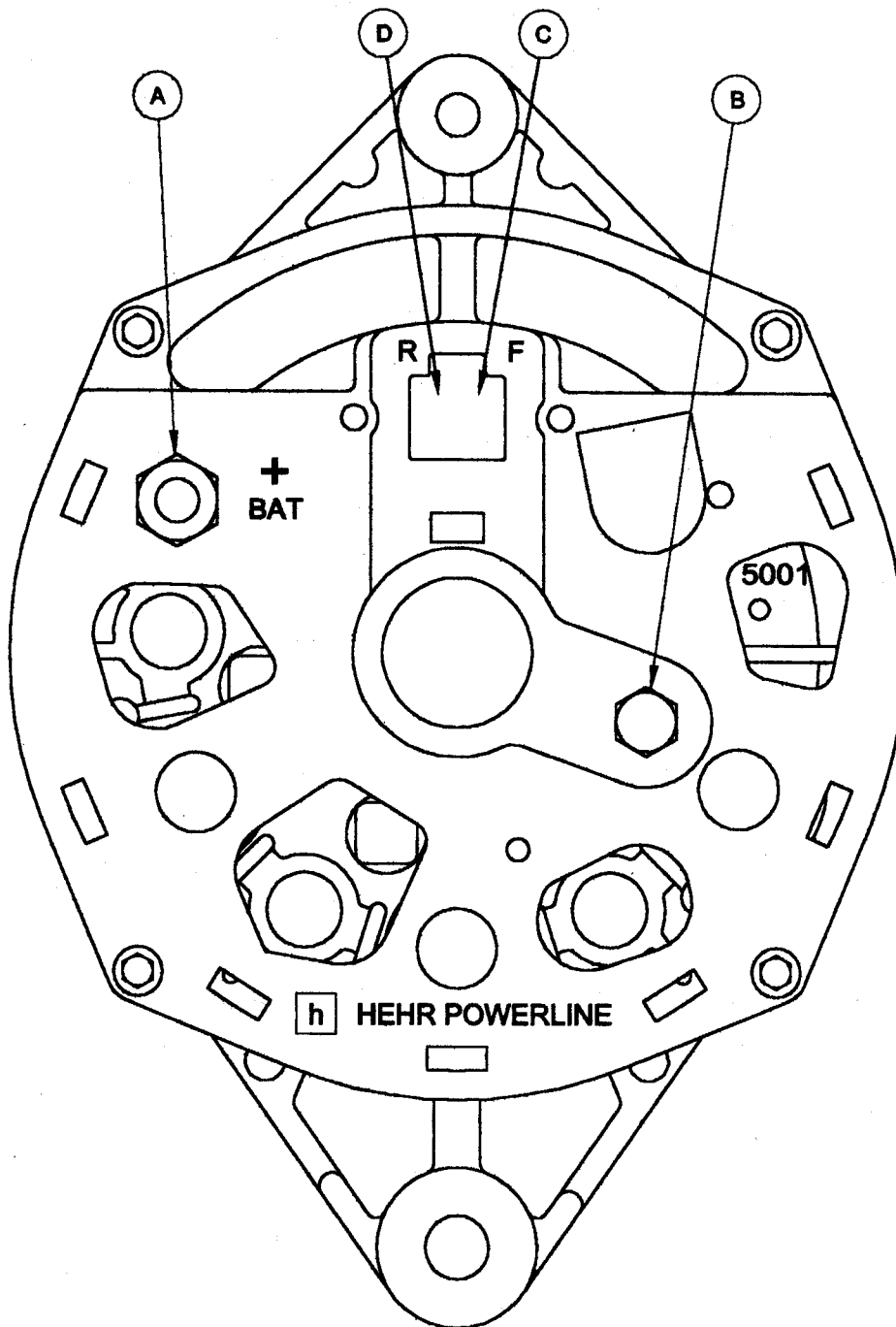

TERMINAL IDENTIFICATION

- A. POSITIVE OUTPUT TERMINAL
- B. GROUND
- C. FIELD
- D. RELAY (R) STATOR TERMINAL

SERIES 23

(ENCLOSED BRUSHES)
(INSULATED FIELD)

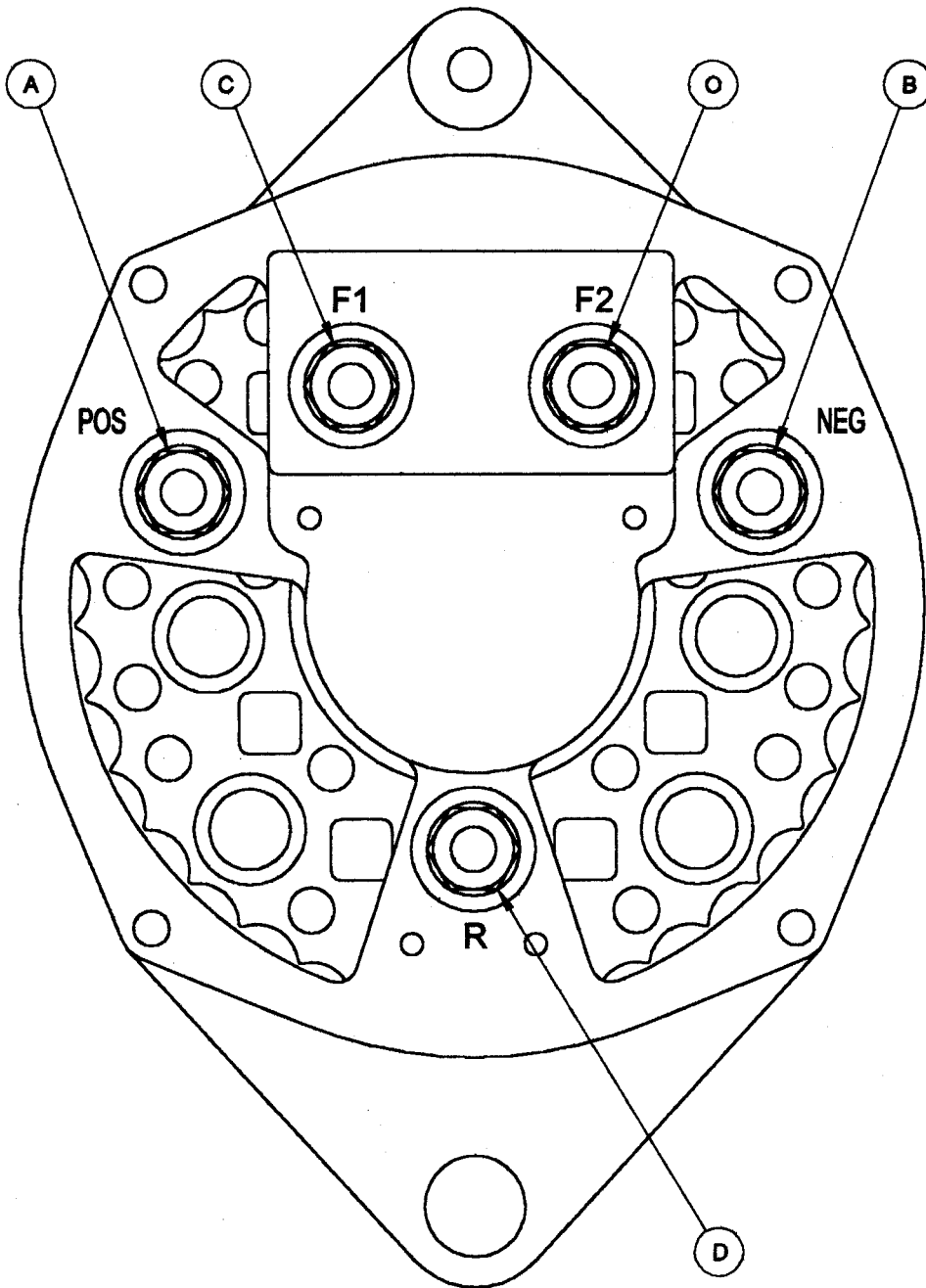

TERMINAL IDENTIFICATION

- A. POSITIVE OUTPUT TERMINAL
- B. NEGATIVE OUTPUT TERMINAL
- C. FIELD (F1) TERMINAL
- D. RELAY (R) STATOR TERMINAL
- E. FIELD (F2) TERMINAL

SERIES 24

(12 VOLT 100, 160, 190 & 220 AMP)

(STANDARD UNITS)

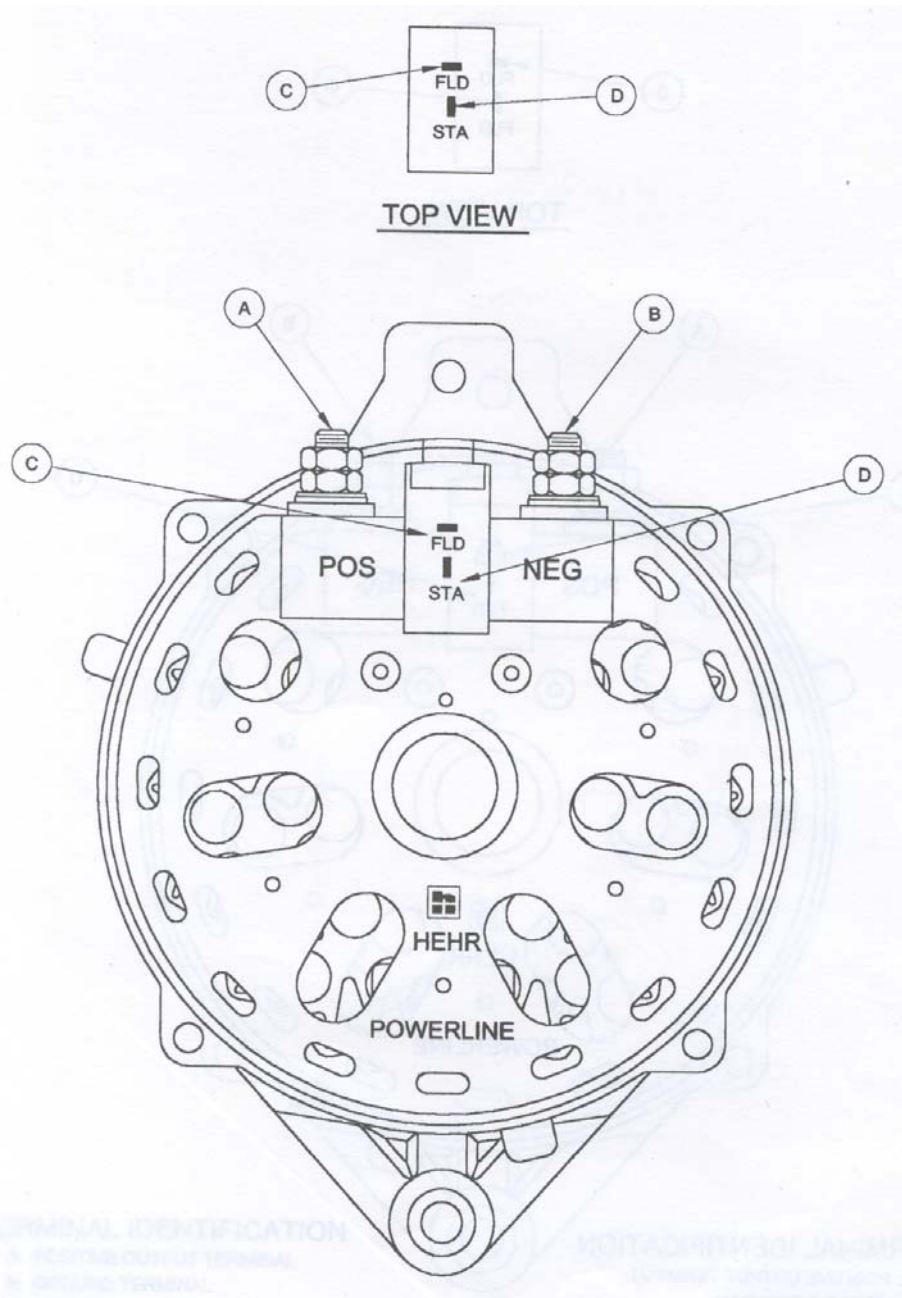

TERMINAL IDENTIFICATION

- A. POSITIVE OUTPUT TERMINAL
- B. GROUND TERMINAL
- C. STATOR TERMINAL
- D. FIELD TERMINAL

SERIES 24

(12 VOLT 100, 160, 190 & 220 AMP)

(INSULATED FIELD UNITS)

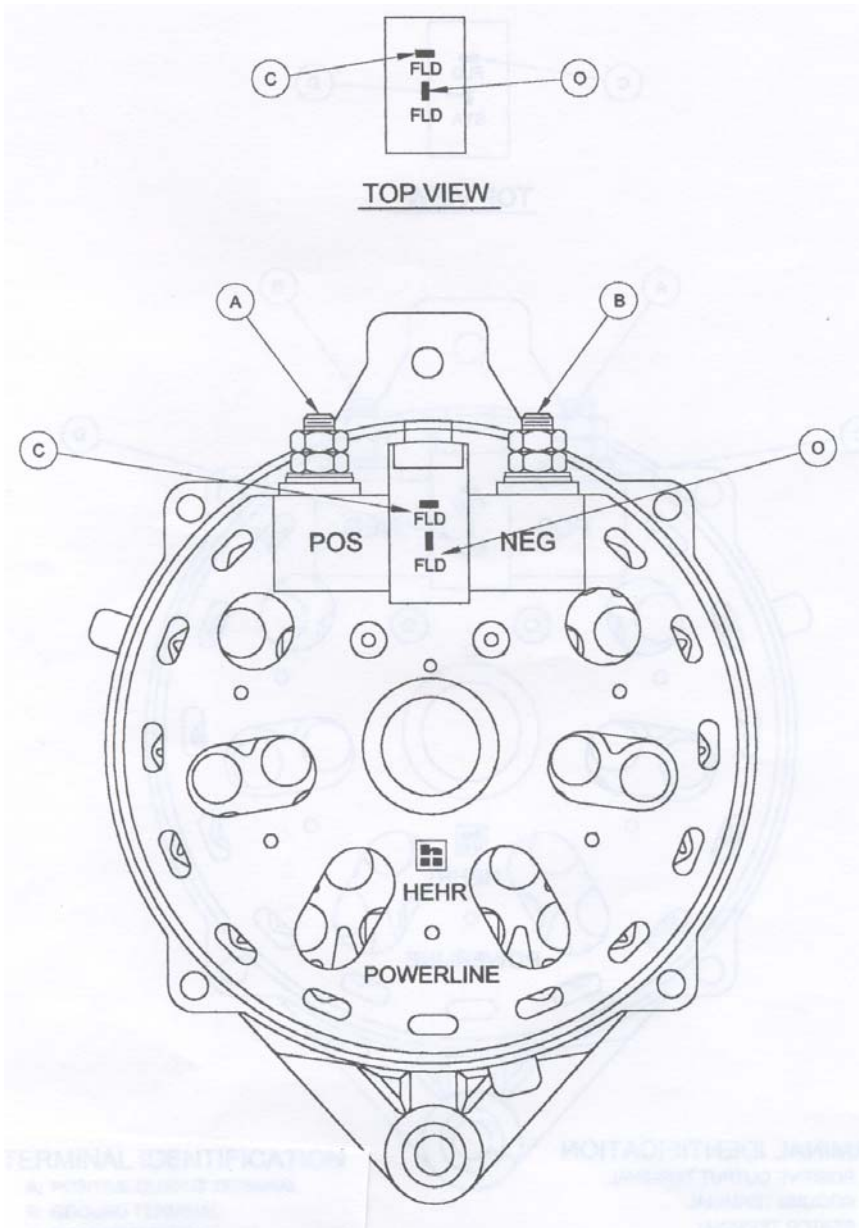

TERMINAL IDENTIFICATION

- A. POSITIVE OUTPUT TERMINAL
- B. GROUND TERMINAL
- C. FIELD TERMINAL
- O. FIELD TERMINAL

SERIES 24

(12 VOLT 100, 160, 190 & 220 AMP)

(EXTERNAL RECTIFIED UNITS)

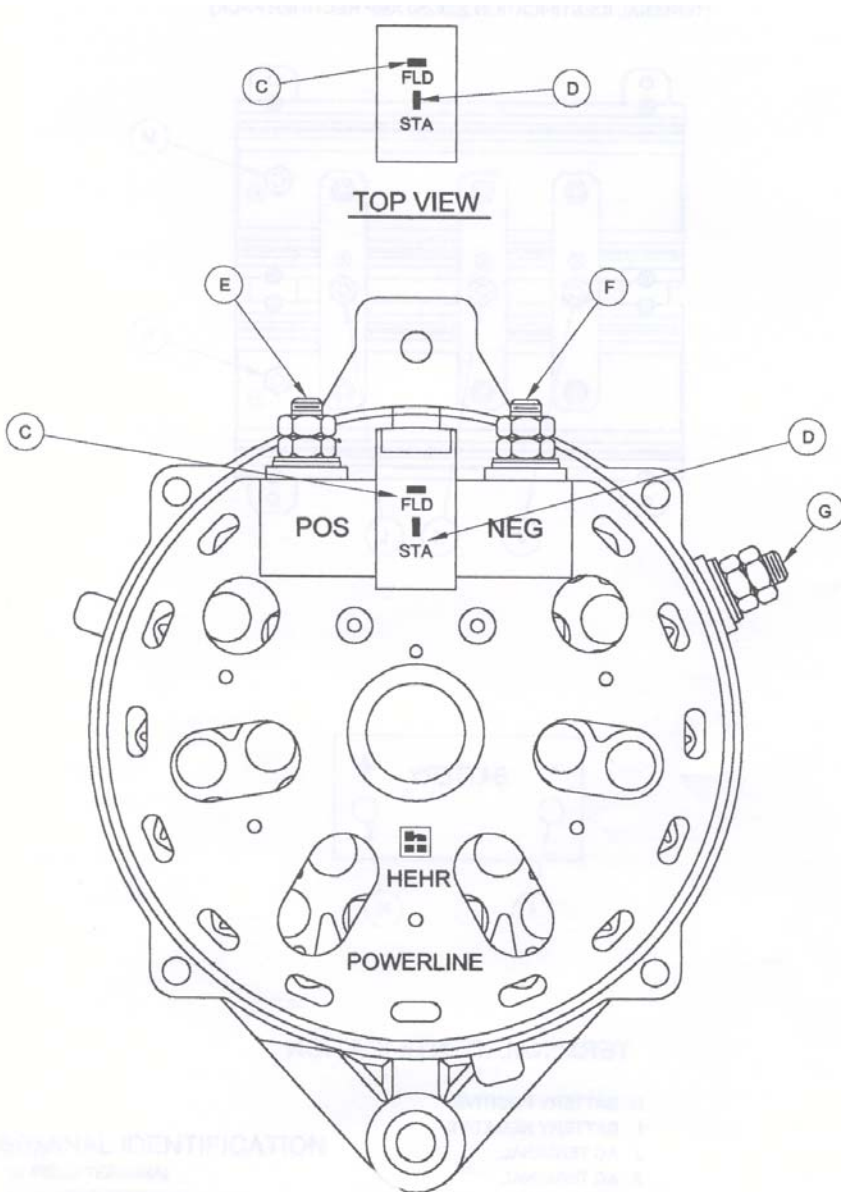

TERMINAL IDENTIFICATION

- C. FIELD TERMINAL
- D. STATOR TERMINAL
- E. AC TERMINAL
- F. AC TERMINAL
- G. AC TERMINAL

EXTERNAL RECTIFIER PACK

(TERMINAL IDENTIFICATION 200/250 AMP RECTIFIER PACK)

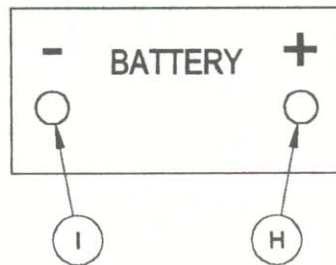
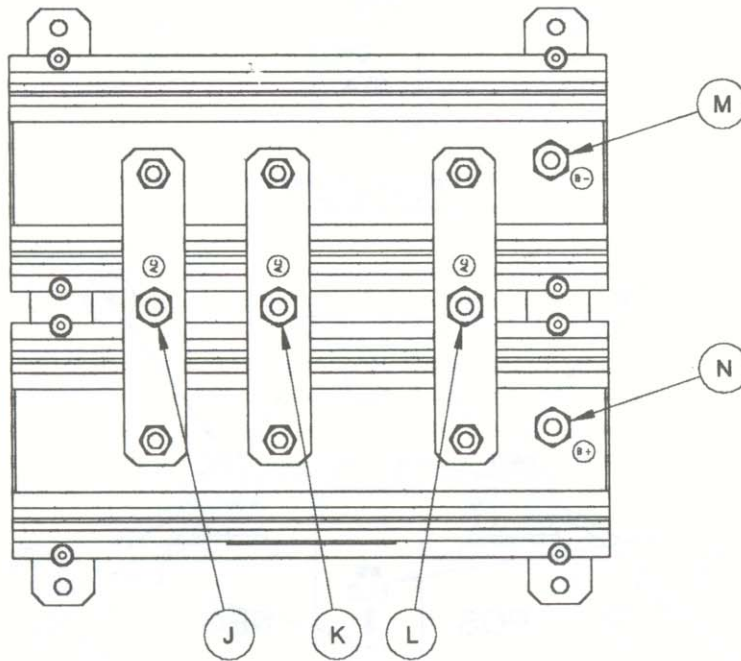

TERMINAL IDENTIFICATION

- H. BATTERY POSITIVE
- I. BATTERY NEGATIVE
- J. AC TERMINAL
- K. AC TERMINAL
- L. AC TERMINAL
- M. POSITIVE RECTIFIER POST
- N. NEGATIVE RECTIFIER POST

ISOLATOR

(TERMINAL IDENTIFICATION AND CONNECTIONS)

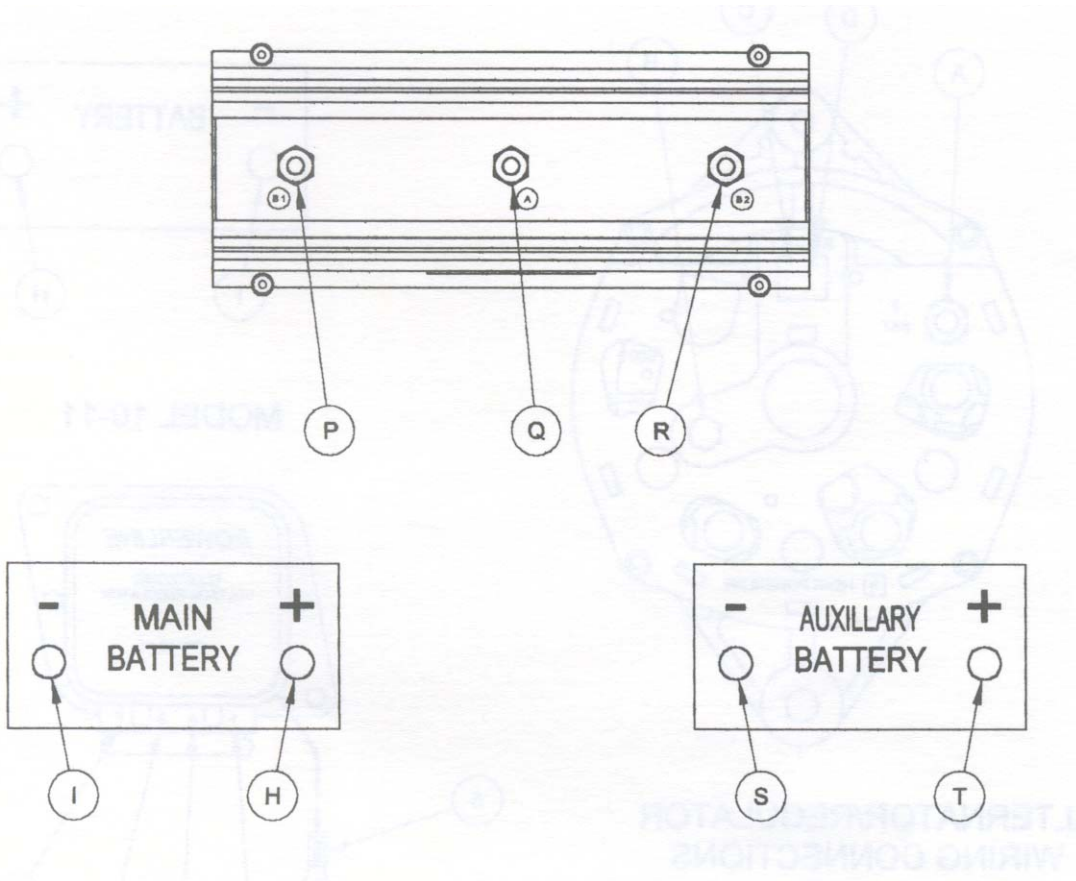

TERMINAL IDENTIFICATION

- H. MAIN BATTERY POSITIVE POST
- I. MAIN BATTERY NEGATIVE POST
- P. MAIN BATTERY POSITIVE POST CONNECTION
- Q. ALTERNATOR INPUT POST
- R. AUXILIARY BATTERY POST POSITIVE CONNECTION
- S. AUXILIARY BATTERY NEGATIVE POST
- T. AUXILIARY BATTERY POSITIVE POST

TERMINAL CONNECTIONS

- H. CONNECTS TO P
- I. CONNECTS TO GROUND
- P. CONNECTS TO H
- Q. CONNECTS TO A ON ALTERNATORS OR M ON RECTIFIER PACK
- R. CONNECTS TO T
- S. CONNECTS TO GROUND
- T. CONNECTS TO R

SERIES 23

(12 VOLT 100, 120 & 150 AMP)

EXTERNAL 10-11 REGULATOR

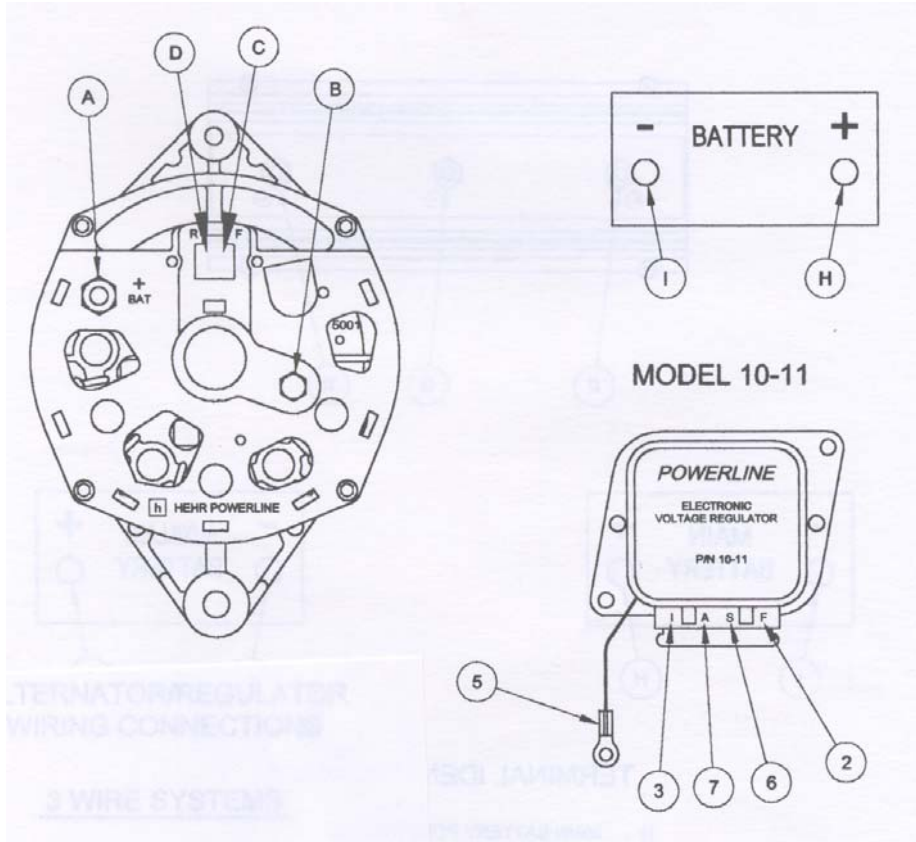

ALTERNATOR / REGULATOR WIRING CONNECTIONS 3 WIRE SYSTEMS

- A. CONNECTS TO H
- B. CONNECTS TO I
- C. CONNECTS TO #2
- D. NOT USED (TACHOMETER CONNECTION)
- 3. NOT USED
- 5. CONNECTS TO B
- 6. CONNECTS TO ON/OFF IGNITION

4 WIRE SYSTEMS

- A. CONNECTS TO H
- B. CONNECTS TO I
- C. CONNECTS TO #2
- D. CONNECTS TO #6 (ALSO TACHOMETER CONNECTION)
- 3. CONNECTS TO ON/OFF IGNITION THRU CHARGE LIGHT
- 5. CONNECTS TO B
- 7. CONNECTS TO H

PIN FUNCTION

- 2. F REGULATOR OUTPUT (DRIVES FIELD WINDING OF ALTERNATOR)
- 3. I TURNS REGULATOR ON (4 WIRE HOOK-UP)
- 5. CASE CIRCUIT GROUND FOR REGULATOR
- 6. S 3 WIRE HOOK-UP (TURNS REGULATOR ON)
4 WIRE HOOK-UP (TURNS WARNING LIGHT OFF WHEN ALTERNATOR IS WORKING)
- 7. A POWER SUPPLY AND VOLTAGE SENSE LEAD FOR REGULATORS (ALL MODELS)

SERIES 23

(12 VOLT 100, 120 & 150 AMP)

EXTERNAL 10-130 REGULATOR

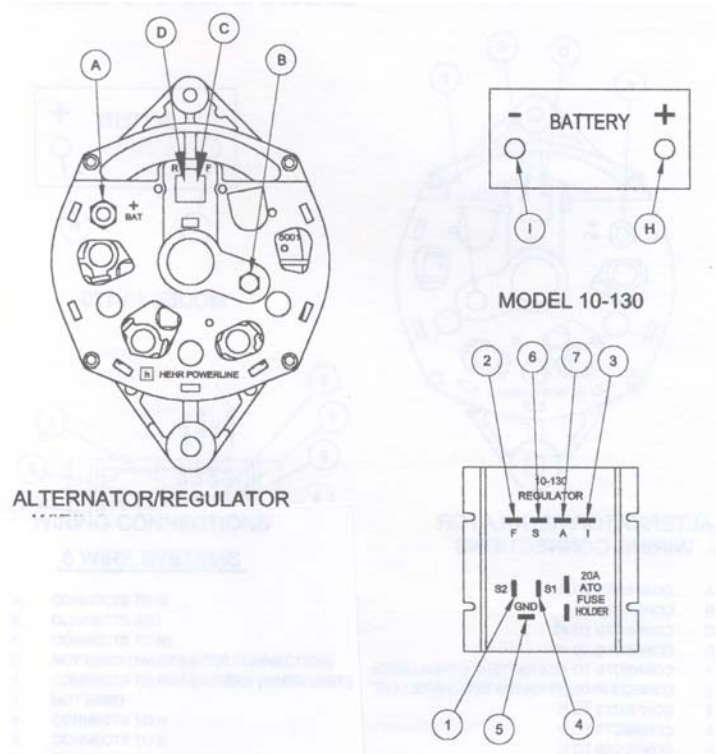

WIRING CONNECTIONS

6 WIRE SYSTEMS

- A. CONNECTS TO H
- B. CONNECTS TO I
- C. CONNECTS TO #2
- D. NOT USED (TACHOMETER CONNECTION)
- 1. CONNECTS TO AUXILIARY BATTERY (WHEN USED)
- 3. NOT USED
- 4. CONNECTS TO H
- 5. CONNECTS TO B
- 6. CONNECTS TO ON/OFF IGNITION

7 WIRE SYSTEMS

- A. CONNECTS TO H
- B. CONNECTS TO I
- C. CONNECTS TO #2
- D. CONNECTS TO #6
- 1. CONNECTS TO AUXILIARY BATTERY (WHEN USED)
- 3. CONNECTS TO ON/OFF IGNITION THRU CHARGE LIGHT
- 4. CONNECTS TO H
- 5. CONNECTS TO B
- 7. CONNECTS TO H

REGULATOR PIN FUNCTION

- 1. S2 REMOTE SENSE FOR THE AUXILIARY BATTERY
- 2. F REGULATOR OUTPUT (DRIVES FIELD WINDING)
- 3. I TURNS REGULATOR ON (4 WIRE HOOK-UP)
- 4. S1 REMOTE SENSE FOR THE MAIN BATTERY
- 5. GND CIRCUIT GROUNDING FOR THE MAIN BATTERY
- 6. S 6 WIRE HOOK-UP (TURNS REGULATOR ON)
7 WIRE HOOK-UP (TURNS WARNING LIGHT OFF WHEN ALTERNATOR IS WORKING)
- 7. A POWER SUPPLY TO REGULATOR AND FIELD

SERIES 23

(12 VOLT 100, 120 & 150 AMP)

EXTERNAL 10-170 & 10-172 REGULATOR

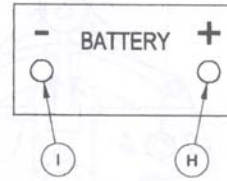
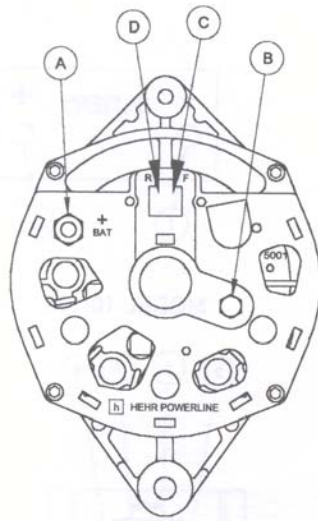

MODEL 10-170

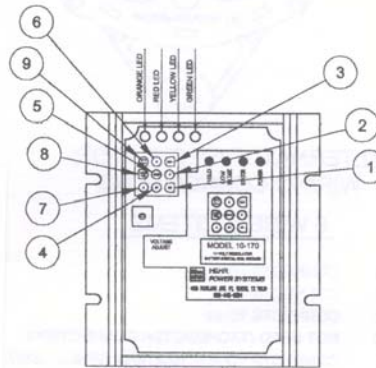

ALTERNATOR / REGULATOR WIRING CONNECTIONS

- A. CONNECTS TO H
- B. CONNECTS TO I
- C. CONNECTS TO #2
- D. CONNECTS TO #6
- 1. CONNECTS TO AUXILIARY BATTERY (WHEN USED)
- 3. CONNECTS TO ON/OFF IGNITION THRU CHARGE LIGHT
- 4. CONNECTS TO H
- 5. CONNECTS TO B
- 7. CONNECTS TO H

REGULATOR PIN FUNCTION

- 1. S2 REMOTE SENSE FOR THE AUXILIARY BATTERY
- 2. F REGULATOR OUTPUT (DRIVES FIELD WINDING)
- 3. I TURNS REGULATOR ON (ON/OFF IGNITION)
- 4. S1 REMOTE SENSE FOR THE MAIN BATTERY
- 5. GND CIRCUIT GROUNDING FOR THE REGULATOR
- 6. S 4 WIRE HOOK-UP (TURNS WARNING LIGHT OFF WHEN ALTERNATOR IS WORKING)
- 7. A POWER SUPPLY TO REGULATOR AND FIELD

SERIES 23

(12 VOLT 100, 120 & 160 AMP)
(MARINE - ENCLOSED INSULATED BRUSHES)

EXTERNAL 10-11 REGULATOR

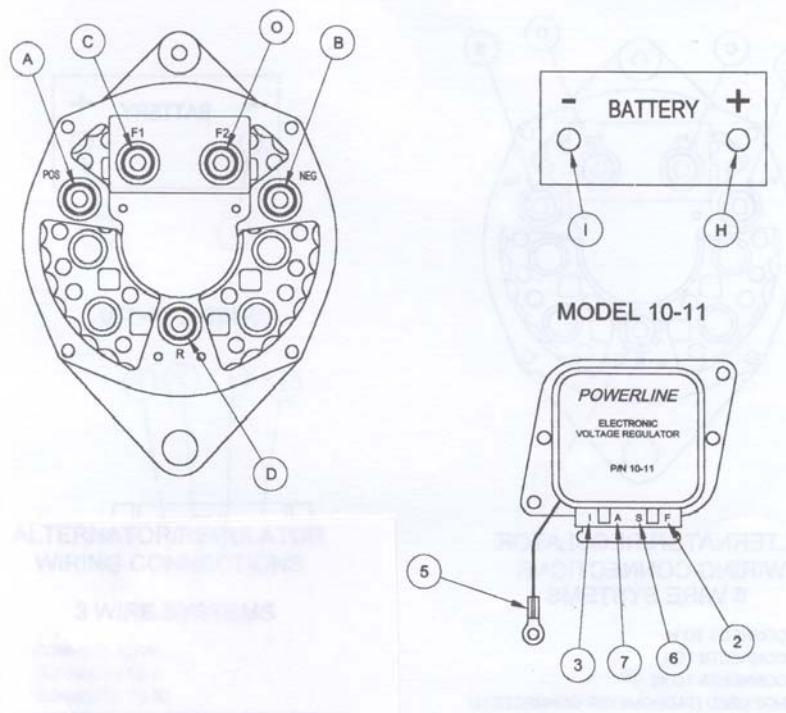

ALTERNATOR / REGULATOR WIRING CONNECTIONS 3 WIRE SYSTEMS

- A. CONNECTS TO H
- B. CONNECTS TO I
- C. CONNECTS TO #2
- D. NOT USED (TACHOMETER CONNECTION)
- O. CONNECTS TO B
- 3. NOT USED
- 5. CONNECTS TO B
- 6. CONNECTS TO ON/OFF IGNITION
- 7. CONNECTS TO H

4 WIRE SYSTEMS

- A. CONNECTS TO H
- B. CONNECTS TO I
- C. CONNECTS TO #2
- D. CONNECTS TO #6 (ALSO TACHOMETER CONNECTION)
- O. CONNECTS TO B
- 3. CONNECTS TO ON/OFF IGNITION THRU CHARGE LIGHT
- 5. CONNECTS TO B
- 7. CONNECTS TO H

PIN FUNCTION

- 2. F REGULATOR OUTPUT (DRIVES FIELD WINDING OF ALTERNATOR)
- 3. I TURNS REGULATOR ON (4 WIRE HOOK-UP)
- 5. CASE CIRCUIT GROUND FOR REGULATOR
- 6. S 3 WIRE HOOK-UP (TURNS REGULATOR ON)
4 WIRE HOOK-UP (TURNS WARNING LIGHT OFF WHEN ALTERNATOR IS WORKING)
- 7. A POWER SUPPLY AND VOLTAGE SENSE LEAD FOR REGULATORS (ALL MODELS)

SERIES 23

(12 VOLT 100, 120 & 160 AMP)
(MARINE - ENCLOSED INSULATED BRUSHES)

EXTERNAL 10-130 REGULATOR

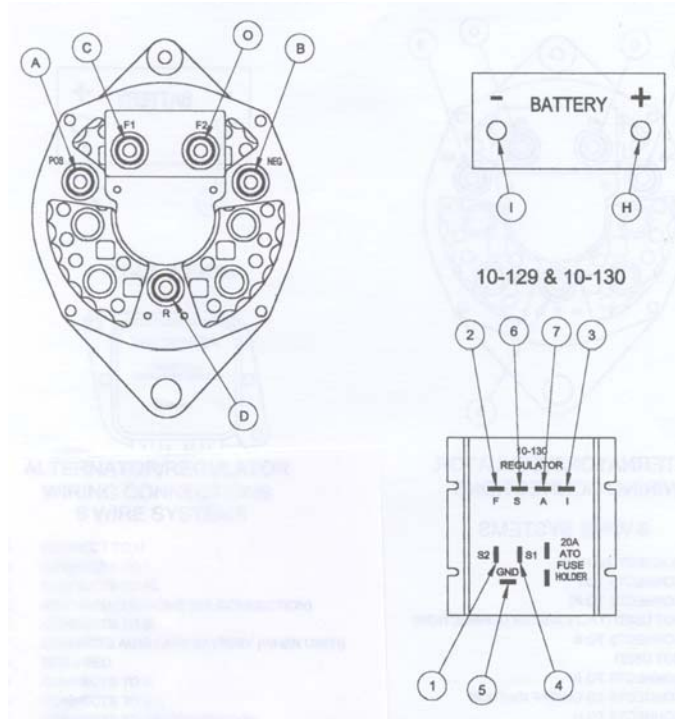

ALTERNATOR / REGULATOR WIRING CONNECTIONS 6 WIRE SYSTEMS

- A. CONNECTS TO H
- B. CONNECTS TO I
- C. CONNECTS TO #2
- D. NOT USED (TACHOMETER CONNECTION)
- O. CONNECTS TO B
- 1. CONNECTS TO AUXILIARY BATTERY (WHEN USED)
- 3. NOT USED
- 4. CONNECTS TO H
- 5. CONNECTS TO B
- 6. CONNECTS TO ON/OFF IGNITION
- 7. CONNECTS TO H

7 WIRE SYSTEMS

- A. CONNECTS TO H
- B. CONNECTS TO I
- C. CONNECTS TO #2
- D. CONNECTS TO #6 (ALSO TACHOMETER CONNECTION)
- O. CONNECTS TO B
- 1. CONNECTS TO AUXILIARY BATTERY (WHEN USED)
- 3. CONNECTS TO ON/OFF IGNITION THRU CHARGE LIGHT
- 4. CONNECTS TO H
- 5. CONNECTS TO B
- 7. CONNECTS TO H

REGULATOR PIN FUNCTION

- 1. S2 REMOTE SENSE FOR THE AUXILIARY BATTERY
- 2. F REGULATOR OUTPUT (DRIVES FIELD WINDING)
- 3. I TURNS REGULATOR ON (4 WIRE HOOK-UP)
- 4. S1 REMOTE SENSE FOR THE MAIN BATTERY
- 5. GND CIRCUIT GROUNDING FOR THE MAIN BATTERY
- 6. S1 6 WIRE HOOK-UP (TURNS REGULATOR ON)
7 WIRE HOOK-UP (TURNS WARNING LIGHT
OFF WHEN ALTERNATOR IS WORKING)
- 7. A POWER SUPPLY TO REGULATOR AND FIELD

SERIES 23

(12 VOLT 100, 120 & 160 AMP)

(MARINE - ENCLOSED INSULATED BRUSHES)

EXTERNAL 10-170 REGULATOR

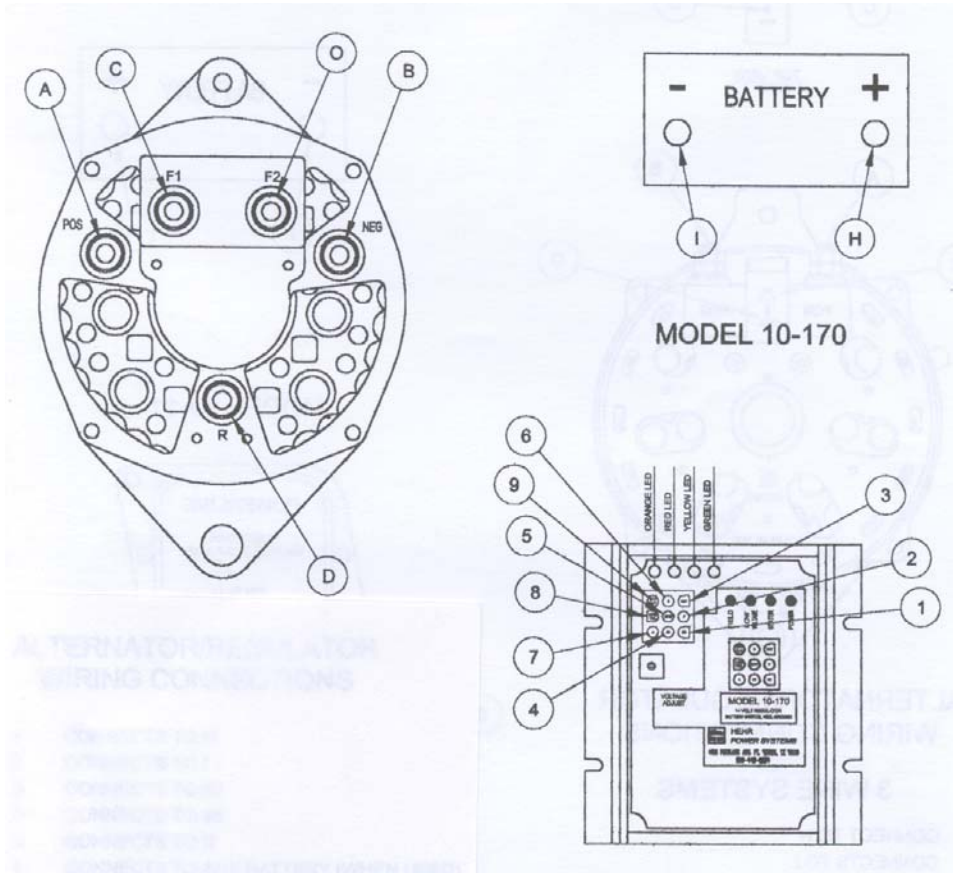

ALTERNATOR / REGULATOR WIRING CONNECTIONS

- A. CONNECTS TO H
- B. CONNECTS TO I
- C. CONNECTS TO #2
- D. CONNECTS TO #6
- O. CONNECTS TO B
- 1. CONNECTS TO AUXILIARY BATTERY (WHEN USED)
- 3. CONNECTS TO ON/OFF IGNITION
- 4. CONNECTS TO H
- 5. CONNECTS TO B
- 7. CONNECTS TO H

REGULATOR PIN FUNCTION

- 1. S2 REMOTE SENSE FOR THE AUXILIARY BATTERY
- 2. F REGULATOR OUTPUT (DRIVES FIELD WINDING)
- 3. I TURNS REGULATOR ON (ON/OFF IGNITION)
- 4. S1 REMOTE SENSE FOR THE MAIN BATTERY
- 5. GND CIRCUIT GROUNDING FOR THE REGULATOR
- 6. S 4 WIRE HOOK-UP (TURNS WARNING LIGHT OFF WHEN ALTERNATOR IS WORKING)
- 7. A POWER SUPPLY TO REGULATOR AND FIELD

SERIES 24

(12 VOLT 100, 160, 190 & 220 AMP)
(STANDARD UNIT)

EXTERNAL 10-11 REGULATOR

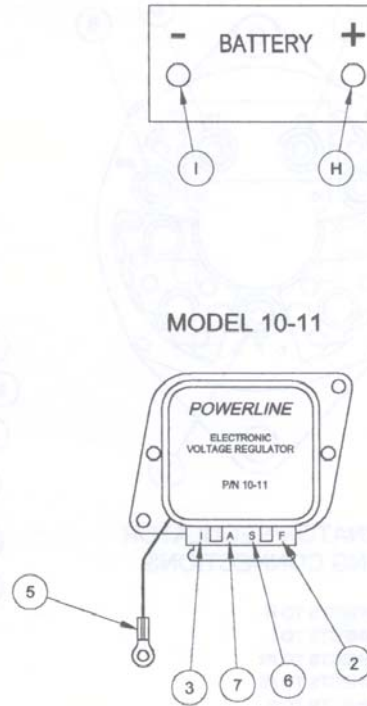
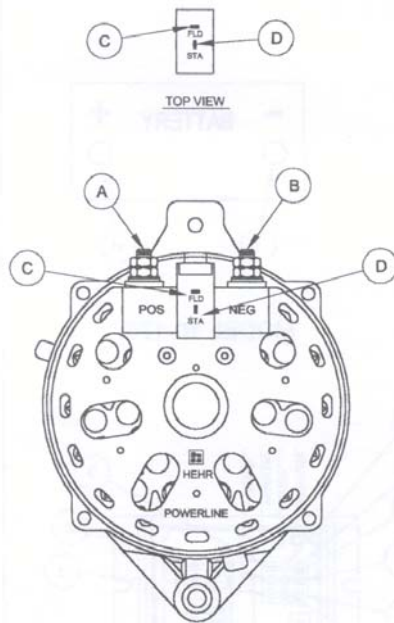

ALTERNATOR / REGULATOR WIRING CONNECTIONS 3 WIRE SYSTEMS

- A. CONNECTS TO H
- B. CONNECTS TO I
- C. CONNECTS TO #2
- D. NOT USED (TACHOMETER CONNECTION)
- 3. NOT USED
- 5. CONNECTS TO B
- 6. CONNECTS TO ON/OFF IGNITION
- 7. CONNECTS TO H

4 WIRE SYSTEMS

- A. CONNECTS TO H
- B. CONNECTS TO I
- C. CONNECTS TO #2
- D. CONNECTS TO #6 (ALSO TACHOMETER CONNECTION)
- 3. CONNECTS TO ON/OFF IGNITION THRU CHARGE LIGHT
- 5. CONNECTS TO B
- 7. CONNECTS TO H

PIN FUNCTION

- 2. F REGULATOR OUTPUT (DRIVES FIELD WINDING OF ALTERNATOR)
- 3. I TURNS REGULATOR ON (4 WIRE HOOK-UP)
- 5. CASE CIRCUIT GROUND FOR REGULATOR
- 6. S 3 WIRE HOOK-UP (TURNS REGULATOR ON)
4 WIRE HOOK-UP (TURNS WARNING LIGHT OFF WHEN ALTERNATOR IS WORKING)
- 7. A POWER SUPPLY AND VOLTAGE SENSE LEAD FOR REGULATORS (ALL MODELS)

SERIES 24
(12 VOLT 100, 160, 190 & 220 AMP)
(STANDARD UNIT)

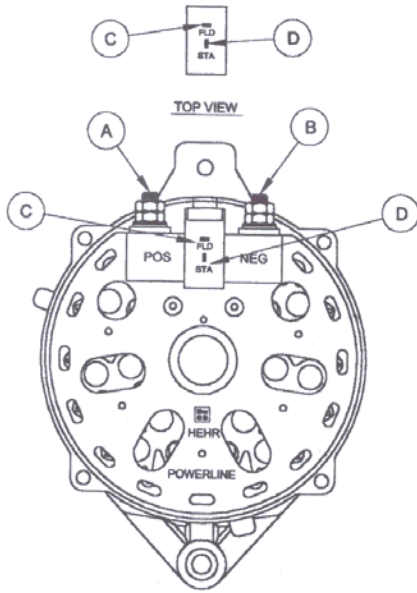

EXTERNAL REGULATOR
10-130

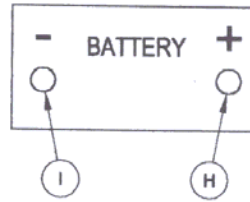

10-129 & 10-130

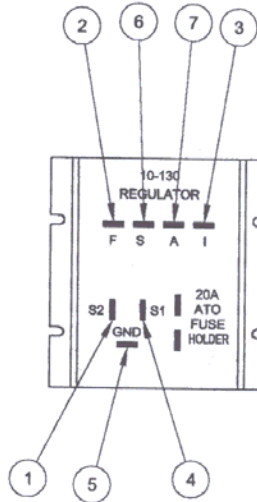

ALTERNATOR / REGULATOR
WIRING CONNECTIONS
6 WIRE SYSTEMS

- A. CONNECTS TO H
- B. CONNECTS TO I
- C. CONNECTS TO #2
- D. NOT USED
- 1. CONNECTS TO AUXILIARY BATTERY (WHEN USED)
- 3. NOT USED
- 4. CONNECTS TO H
- 5. CONNECTS TO B
- 6. CONNECTS TO ON/OFF IGNITION

7 WIRE SYSTEMS

- A. CONNECTS TO H
- B. CONNECTS TO I
- C. CONNECTS TO #2
- D. CONNECTS TO #6
- 1. CONNECTS TO AUXILIARY BATTERY (WHEN USED)
- 3. CONNECTS TO ON/OFF IGNITION
- 4. CONNECTS TO H
- 5. CONNECTS TO B
- 6. CONNECTS TO D
- 7. CONNECTS TO H

REGULATOR PIN FUNCTION

- 1. S2 REMOTE SENSE FOR THE AUXILIARY BATTERY
- 2. F REGULATGOR OUTPUT (DRIVES FIELD WINDING)
- 3. I TURNS REGULATOR ON (7 WIRE HOOK-UP)
- 4. S1 REMOTE SENSE FOR THE MAIN BATTERY
- 5. GND CIRCUIT GROUNDING FOR THE MAIN BATTERY
- 6. S1 6 WIRE HOOK-UP (TURNS REGULATOR ON)
7 WIRE HOOK-UP (TURNS WARNING LIGHT OFF WHEN ALTERNATOR IS WORKING)
- 7. A POWER SUPPLY TO REGULATOR AND FIELD

SERIES 24
 (12 VOLT 100, 160, 190 & 220 AMP)
 (STANDARD UNIT)

EXTERNAL REGULATOR
 10-170 & 10-172

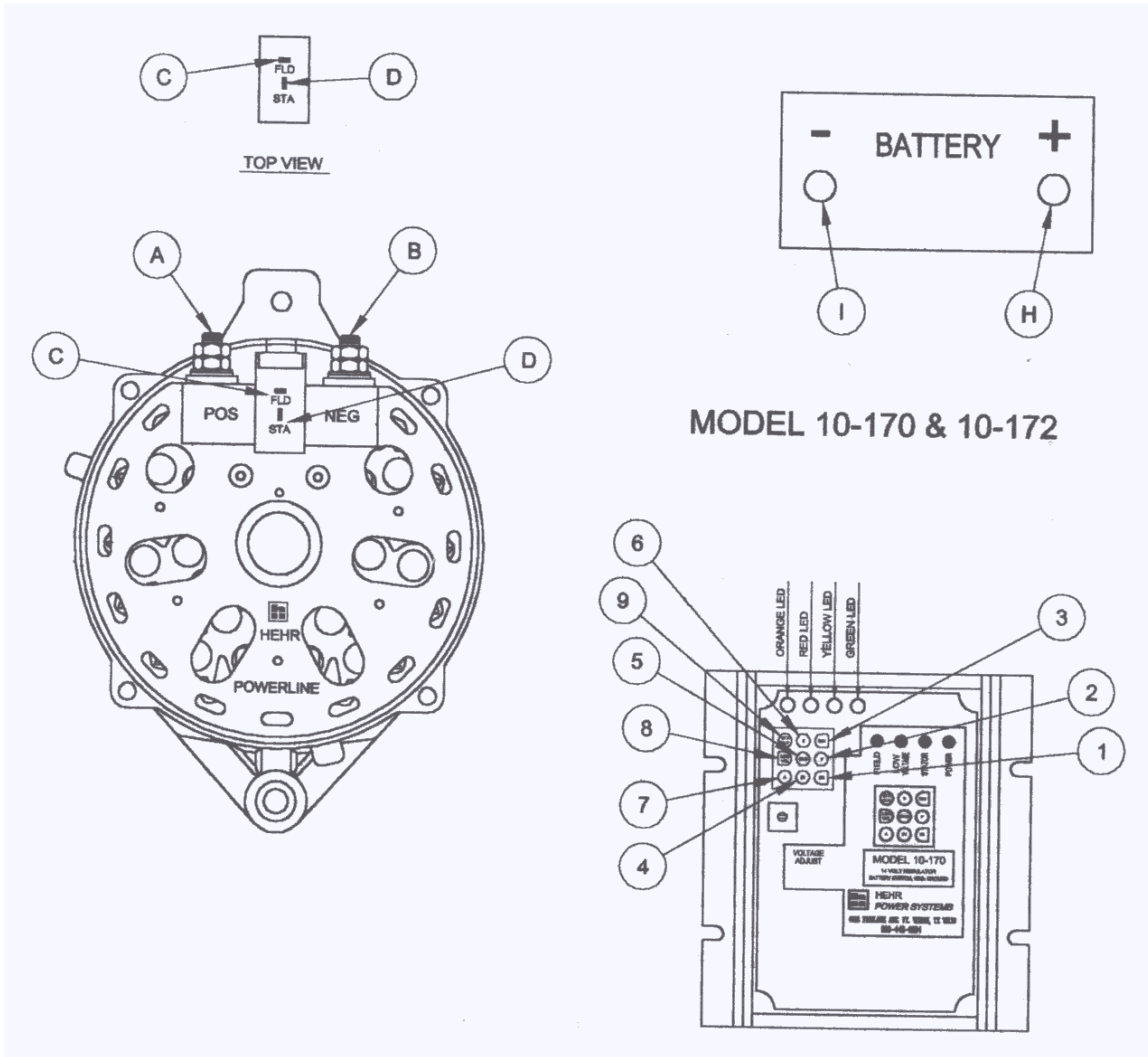

ALTERNATOR / REGULATOR
 WIRING CONNECTIONS

- A. CONNECTS TO H
- B. CONNECTS TO I
- C. CONNECTS TO #2
- D. CONNECTS TO #6
- 1. CONNECTS TO AUXILIARY BATTERY
- 3. CONNECTS TO ON/OFF IGNITION
- 4. CONNECTS TO H
- 5. CONNECTS TO B
- 6. CONNECTS TO H

REGULATOR PIN FUNCTION

- 1. S2 REMOTE SENSE FOR THE AUXILIARY BATTERY
- 2. F REGULATOR OUTPUT (DRIVES FIELD WINDING)
- 3. I TURNS REGULATOR ON (ON/OFF IGNITION)
- 4. S1 REMOTE SENSE FOR THE MAIN BATTERY
- 5. GND CIRCUIT GROUNDING FOR THE REGULATOR
- 6. S 7 WIRE HOOK-UP (TURNS WARNING LIGHT OFF WHEN ALTERNATOR IS WORKING)
- 7. A POWER SUPPLY TO REGULATOR AND FIELD

SERIES 24
 (12 VOLT 100, 160, 190 & 220 AMP)
 (INSULATED FIELD)

EXTERNAL 10-11 REGULATOR

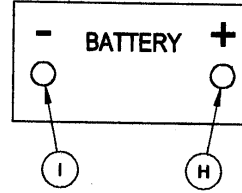
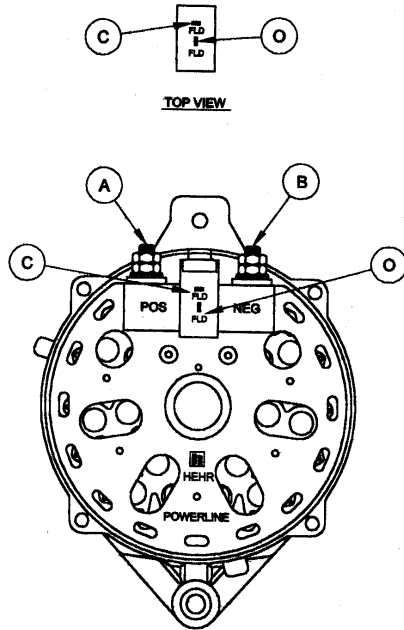

MODEL 10-11

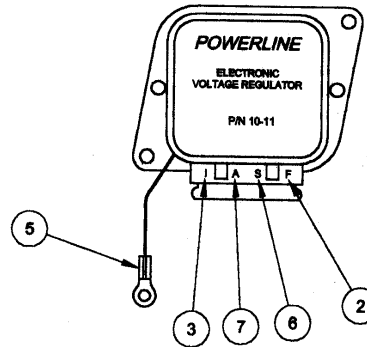

ALTERNATOR / REGULATOR
 WIRING CONNECTIONS
 3 WIRE SYSTEMS

- A. CONNECTS TO H
- B. CONNECTS TO I
- C. CONNECTS TO #2
- O. CONNECTS TO B
- 3. NOT USED
- 5. CONNECTS TO B
- 6. CONNECTS TO ON/OFF IGNITION
- 7. CONNECTS TO H

CHRYSLER/OSHKOSH APPLICATION

- A. CONNECTS TO H
- B. CONNECTS TO I
- C. CONNECTS TO ON/OFF IGNITION
- O. CONNECTS TO VEHICLE ENGINE COMPUTER REGULATOR

NOTE: IF A 3 WIRE REGULATOR IS USED IN THE ABOVE APPLICATION, A PART NUMBER 11-53 MUST BE INSTALLED BETWEEN THE 2 OEM ALTERNATOR FIELD WIRES

PIN FUNCTION

- 2. F REGULATOR OUTPUT (DRIVES FIELD WINDING OF ALTERNATOR)
- 3. I TURNS REGULATOR ON (4 WIRE HOOK-UP)
- 5. CASE CIRCUIT GROUND FOR REGULATOR
- 6. S 3 WIRE HOOK-UP (TURNS REGULATOR ON) 4 WIRE HOOK-UP (TURNS WARNING LIGHT OFF WHEN ALTERNATOR IS WORKING)
- 7. A POWER SUPPLY AND VOLTAGE SENSE LEAD FOR REGULATORS (ALL MODELS)

NOTE: BRUSHES MUST BE CHANGED TO USE REMOTE REGULATOR

SERIES 24
(12 VOLT 100, 160, 190 & 220 AMP)
(INSULATED FIELD)

EXTERNAL 10-130 REGULATOR

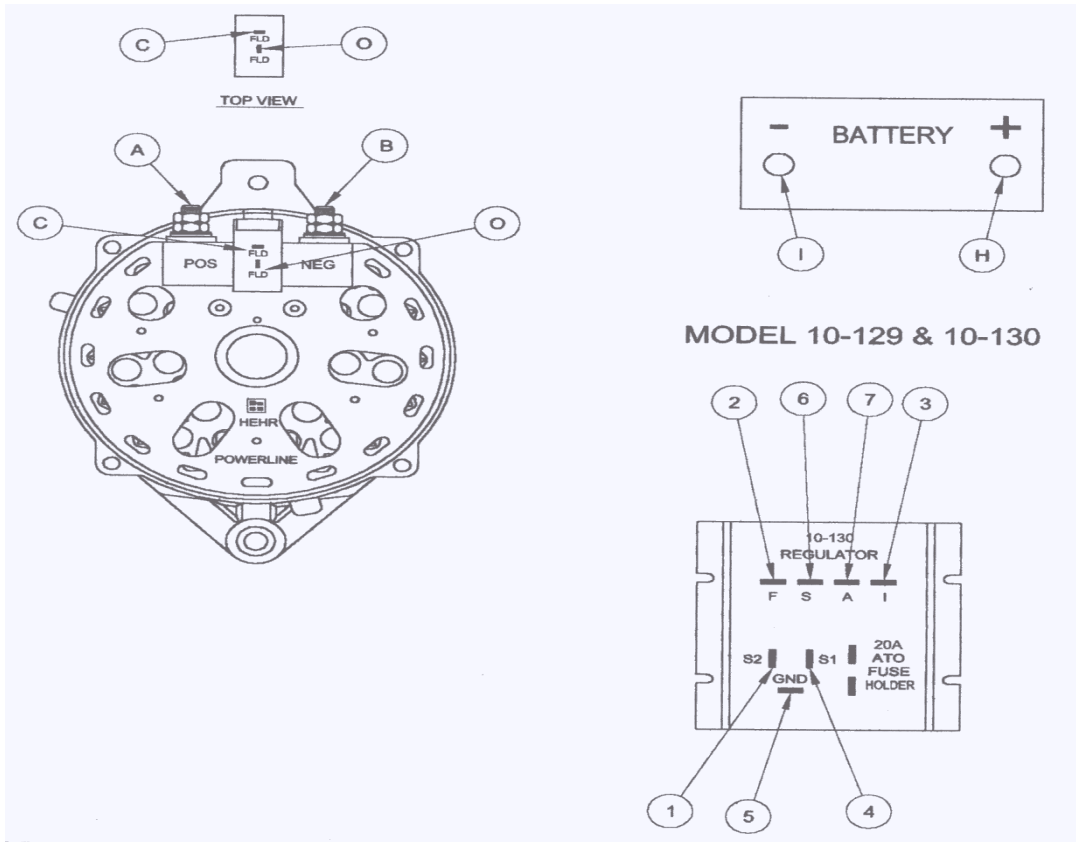

ALTERNATOR / REGULATOR
WIRING CONNECTIONS
6 WIRE SYSTEMS

- A. CONNECTS TO H
- B. CONNECTS TO I
- C. CONNECTS TO #2
- O. CONNECTS TO B
- 1. CONNECTS TO AUXILIARY BATTERY (WHEN USED)
- 3. NOT USED
- 4. CONNECTS TO H
- 5. CONNECTS TO B
- 7. CONNECTS TO H

CHRYSLER/OSHKOSH APPLICATION

- A. CONNECTS TO H
- B. CONNECTS TO I
- C. CONNECTS TO ON/OFF IGNITION
- O. CONNECTS TO REGULATOR IN THE ENGINE COMPUTER

NOTE: THE OEM FIELD LEADS MUST HAVE A 11-53 RESISTOR KIT INSTALLED BETWEEN THEM TO TURN OFF THE ENGINE SERVICE LIGHT

MODEL 10-129 & 10-130

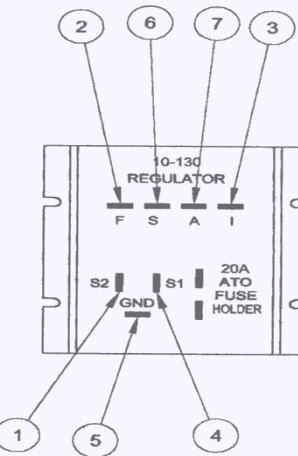

REGULATOR PIN FUNCTION

- 1. S2 REMOTE SENSE FOR THE AUXILIARY BATTERY
- 2. F REGULATOR OUTPUT (DRIVES FIELD WINDING)
- 3. I NOT USED
- 4. S1 REMOTE SENSE FOR THE MAIN BATTERY
- 5. GND CIRCUIT GROUNDING FOR THE MAIN BATTERY
- 6. S 6 WIRE HOOK-UP (TURNS REGULATOR ON)
- 7. A POWER SUPPLY TO REGULATOR AND FIELD

NOTE: BRUSHES MUST BE CHANGED TO USE REMOTE REGULATOR

SERIES 24
(12 VOLT 100, 160, 190 & 220 AMP)
(INSULATED FIELD)

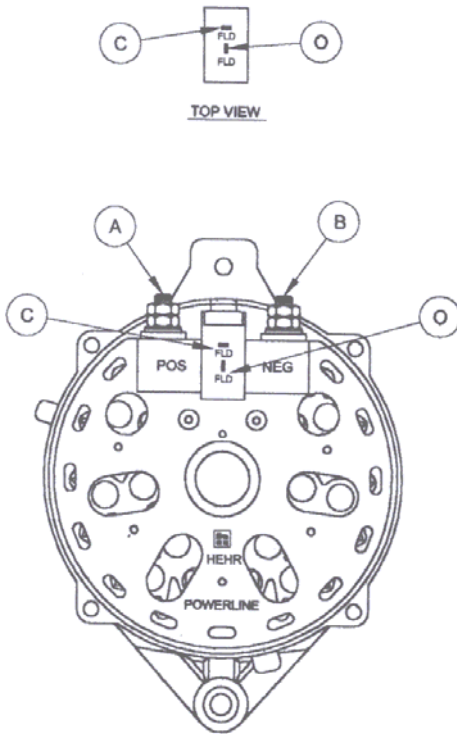

EXTERNAL REGULATOR
10-170 & 10-172

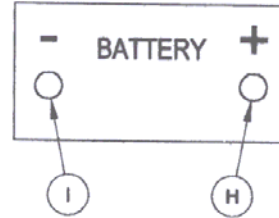

MODEL 10-170 & 10-172

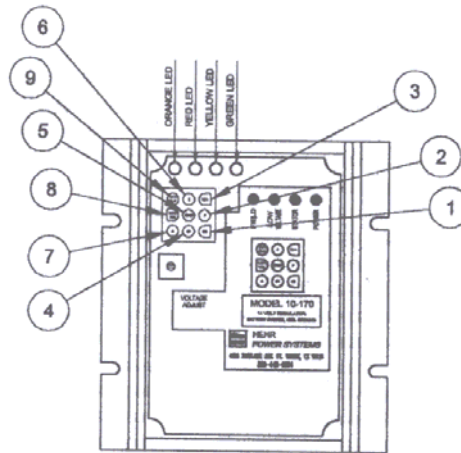

ALTERNATOR / REGULATOR
WIRING CONNECTIONS
7 WIRE SYSTEMS

- A. CONNECTS TO H
- B. CONNECTS TO I

TO INSTALL A 10-170 STYLE REGULATOR ON THE ORIGINAL CHRYSLER/OSHKOSH INSULATED FIELD ALTERNATOR

1. REPLACE THE BRUSHES WITH A 6-20 BRUSH ASSEMBLY KIT
2. USE A 11-81 WIRING HARNESS TO CONNECT BETWEEN THE ALTERNATOR AND THE REGULATOR
3. FOLLOW CONNECTION GUIDE FOR STANDARD ALTERNATOR PAGE # 23
4. INSTALL A 11-53 RESISTOR KIT BETWEEN THE OEM FIELD LEADS

REGULATOR PIN FUNCTION

- | | | |
|----|-----|---|
| 1. | S2 | REMOTE SENSE FOR THE AUXILIARY BATTERY |
| 2. | F | REGULATOR OUTPUT (DRIVES FIELD WINDING) |
| 3. | I | TURNS REGULATOR ON (ON/OFF IGNITION) |
| 4. | S1 | REMOTE SENSE FOR THE MAIN BATTERY |
| 5. | GND | CIRCUIT GROUNDING FOR THE REGULATOR |
| 6. | S | 7 WIRE HOOK-UP (TURNS WARNING LIGHT OFF WHEN ALTERNATOR IS WORKING) |
| 7. | A | POWER SUPPLY TO REGULATOR AND FIELD |

SERIES 24
(12 VOLT 100, 160, 190 & 220 AMP)

EXTERNAL10-11 REGULATOR

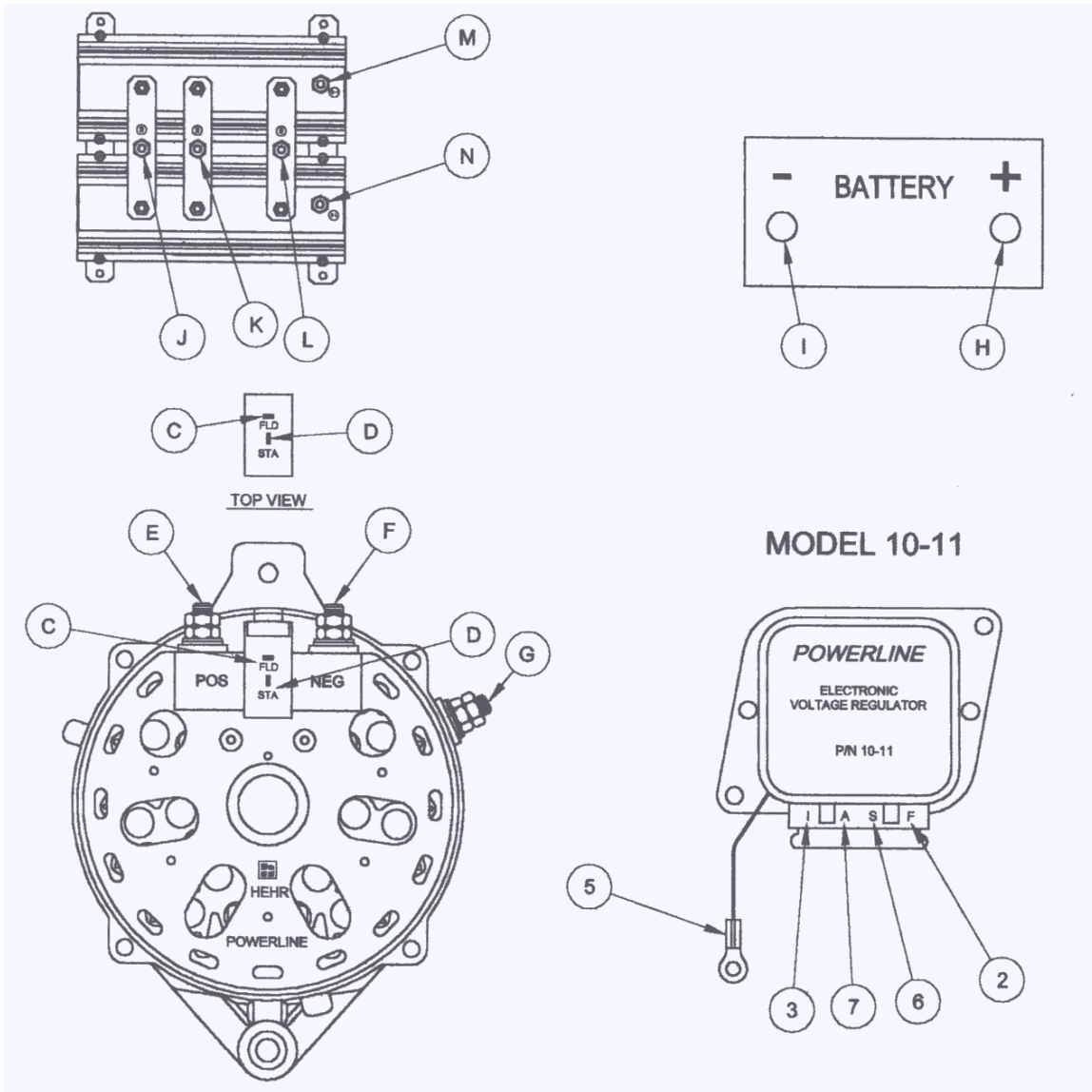

ALTERNATOR / REGULATOR

WIRING CONNECTIONS

- C. CONNECTS TO #2
- D. CONNECTS TO #6 ON A 4 WIRE SYSTEM
- E, F, G. CONNECTS TO J, K, L
- N. CONNECTS TO I
- M. CONNECTS TO H
- 3. CONNECTS TO ON/OFF IGNITION ON A 4 WIRE SYSTEM
- 5. CONNECTS TO ENGINE GROUND
- 6. CONNECTS TO STATOR ON 4 WIRE SYSTEMS
CONNECTS TO ON/OFF IGNITION ON 3 WIRE SYSTEMS
- 7. CONNECTS TO H

PIN FUNCTION

- 2. F REGULATOR OUTPUT (DRIVES FIELD WINDING OF ALTERNATOR)
- 3. I TURNS REGULATOR ON (4 WIRE HOOK-UP)
- 5. CASE CIRCUIT GROUND FOR REGULATOR
- 6. S 3 WIRE HOOK-UP (TURNS REGULATOR ON)
4 WIRE HOOK-UP (TURNS WARNING LIGHT OFF WHEN ALTERNATOR IS WORKING)
- 7. A POWER SUPPLY AND VOLTAGE SENSE LEAD FOR REGULATORS (ALL MODELS)

SERIES 24
(12 VOLT 100, 160, 190 & 220 AMP)

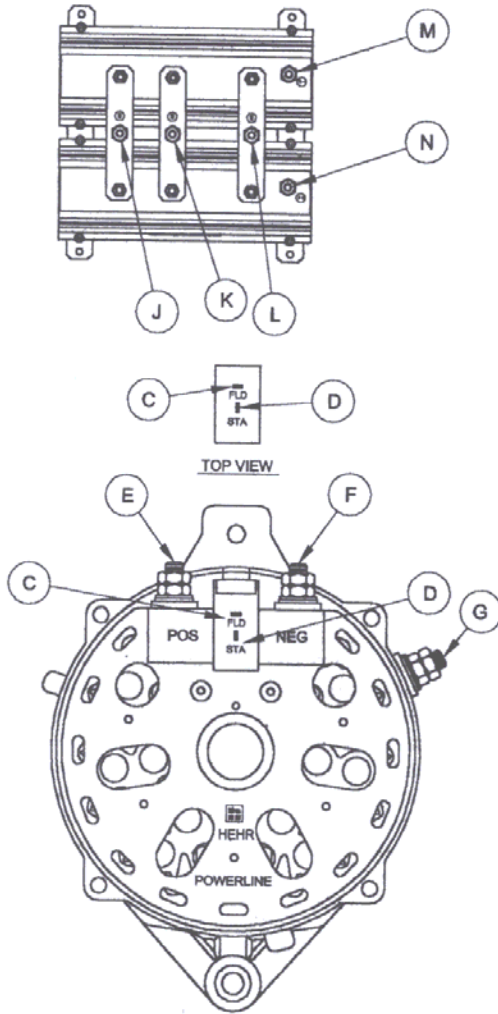

**EXTERNAL 10-130 REGULATOR
RECTIFIER PACK**

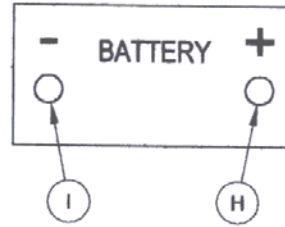

MODEL 10-129 & 10-130

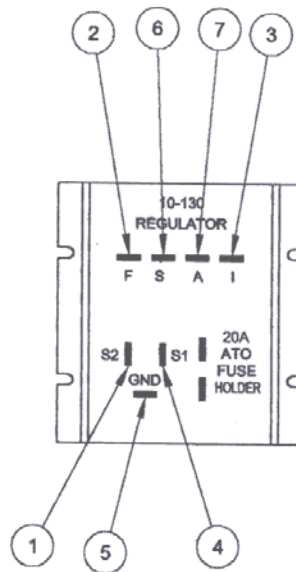

**ALTERNATOR / REGULATOR
WIRING CONNECTIONS**

- C. CONNECTS TO #2
- D. CONNECTS TO #6 ON A 7 WIRE SYSTEM
- E, F, G. CONNECTS TO J, K, L
- N. CONNECTS TO I
- M. CONNECTS TO H
- 1. CONNECTS TO AUXILIARY BATTERY (WHEN USED)
- 3. CONNECTS TO ON/OFF IGNITION
- 4. CONNECTS TO AUXILIARY BATTERY
- 5. CONNECTS TO ENGINE GROUND
- 6. CONNECTS TO ON/OFF IGNITION (3 WIRE)
SYSTEM #3 IS NOT USED
- 7. CONNECTS TO H

REGULATOR PIN FUNCTION

- 1. S2 REMOTE SENSE FOR THE AUXILIARY BATTERY
- 2. F REGULATOR OUTPUT (DRIVES FIELD WINDING)
- 3. I TURNS REGULATOR ON (4 WIRE HOOK-UP)
- 4. S1 REMOTE SENSE FOR THE MAIN BATTERY
- 5. GND CIRCUIT GROUNDING FOR THE MAIN BATTERY
- 6. S 6 WIRE HOOK-UP (TURNS REGULATOR ON)
- 7. 7 WIRE HOOK-UP (TURNS WARNING LIGHT
OFF IF SYSTEM IS WORKING)
- 7. A POWER SUPPLY TO REGULATOR AND FIELD

SERIES 24

(12 VOLT 100, 160, 190 & 220 AMP)

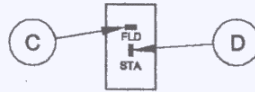
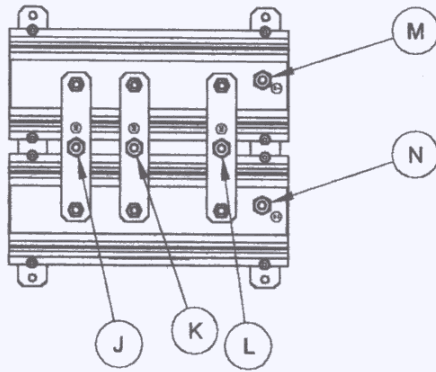

TOP VIEW

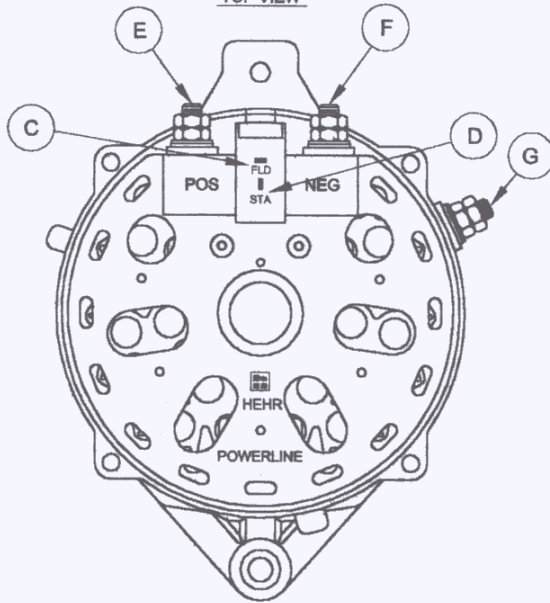

EXTERNAL 10-170 & 10-172 REGULATOR AND RECTIFIER PACK

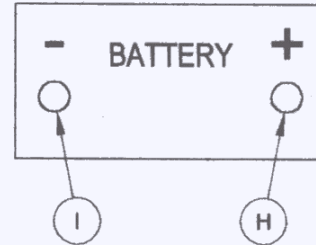

MODEL 10-170 & 10-172

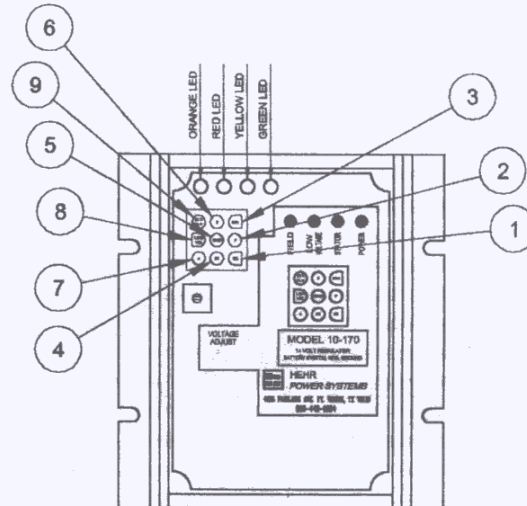

ALTERNATOR / REGULATOR WIRING CONNECTIONS

- C. CONNECTS TO #2
- D. CONNECTS TO #6
- E, F, G. CONNECTS TO J, K, L
- N. CONNECTS TO I
- M. CONNECTS TO H
- 1. CONNECTS TO POSITIVE AUXILIARY BATTERY
- 3. CONNECTS TO ON/OFF IGNITION
- 4. CONNECTS TO POSITIVE AUXILIARY BATTERY
- 5. CONNECTS TO ENGINE GROUND
- 6. CONNECTS TO POSITIVE MAIN BATTERY

REGULATOR PIN FUNCTION

- 1. S2 REMOTE SENSE FOR THE AUXILIARY BATTERY
- 2. F REGULATOR OUTPUT (DRIVES FIELD WINDING)
- 3. I TURNS REGULATOR ON (ON/OFF IGNITION)
- 4. S1 REMOTE SENSE FOR THE MAIN BATTERY
- 5. GND CIRCUIT GROUNDING FOR THE REGULATOR
- 6. S STATOR CONNECTION (COMPLETES REGULATOR TURN ON)
- 7. A POWER SUPPLY TO REGULATOR AND FIELD

VOLTAGE TEST FOR 10-11 REGULATOR 23 AND 24 SERIES ALTERNATOR

3 WIRE CONNECTIONS

TERM #	TERMINALS	IGNITION OFF	IGNITION ON ENGINE NOT RUNNING	ENGINE RUNNING
3	Reg Term I	Not Used	Not Used	Not Used
7	Reg Term A	12.6 Volts	12.6 Volts Approx.	14 Volts
6	Reg Term S	0 Volts	12 Volts Approx.	13-14 Volts
2	Reg Term F	0 Volts	10-11 Volts Approx.	4-12 Volts
D	Alt. R/S Term	0 Volts	0 Volts	7 Volts
C	Alt. F Term	0 Volts	10-11 Volts Approx.	4-12 Volts
A	Alt. Pos. Term	12.6 Volts	12.6 Volts	14 Volts
Q	*Isol A Term	0 Volts	0 Volts	14.5 - 15 Volts
P	*Isol B1 Term	12.6 Volts	12.6 Volts	13.5 - 14 Volts
R	*Isol B2 Term	12.6 Volts	12.6 Volts	13.5 - 14 Volts
A	*Alt. Positive term w/Isol.	0 Volts	0 Volts	14.5 - 15 Volts

***Test points when isolator used**

7 WIRE CONNECTIONS

TERM #	TERMINALS	IGNITION OFF	IGNITION ON ENGINE NOT RUNNING	ENGINE RUNNING
3	Reg Term I	0 Volts	2 Volts Approx.	2-10 Volts
7	Reg Term A	12.6 Volts	12.6 Volts	14 Volts
6	Reg Term S	0 Volts	0 Volts	7 Volts Approx.
2	Reg Term F	0 Volts	10-11 Volts	4-11 Volts
D	Alt. R/S Term	0 Volts	0 Volts	7 Volts Approx.
C	Alt. F Term	0 Volts	10-11 Volts	4-11 Volts
A	Alt. Pos. Term	12.6 Volts	12.6 Volts	14 Volts
Q	*Isol A Term	0 Volts	0 Volts	14.5 - 15 Volts
P	*Isol B1 Term	12.6 Volts	12.6 Volts	13.5 - 14 Volts
R	*Isol B2 Term	12.6 Volts	12.6 Volts	13.5 - 14 Volts
A	*Alt. Positive term w/Isol.	0 Volts	0 Volts	14.5 - 15 Volts

***Test points when isolator used**

VOLTAGE TEST FOR 10-130 REGULATOR 23 AND 24 SERIES ALTERNATOR

6 WIRE CONNECTIONS				
TERM #	TERMINALS	IGNITION OFF	IGNITION ON ENGINE NOT RUNNING	ENGINE RUNNING
3	Reg Term I	Not Used	Not Used	Not Used
7	Reg Term A	12.6 Volts	12.6 Volts	14 Volts
6	Reg Term S	0 Volts	12 Volts Approx.	13-14 Volts
2	Reg Term F	0 Volts	10-11 Volts	4-11 Volts
4	Reg Term, S1	12.6 Volts	12.6 Volts	14 Volts
1	*Reg Term S2	12.6 Volts	12.6 Volts	14 Volts
D	Alt. R/S Term	0 Volts	0 Volts	7 Volts
C	Alt. F Term	0 Volts	10-11 Volts	4-11 Volts
A	Alt. Pos. Term	12.6 Volts	12.6 Volts	14 Volts
Q	*Isol A Term	0 Volts	0 Volts	14.5 - 15 Volts
P	*Isol B1 Term	12.6 Volts	12.6 Volts	13.5 - 14 Volts
R	*Isol B2 Term	12.6 Volts	12.6 Volts	13.5 - 14 Volts
A	*Alt. Positive term w/Isol.	0 Volts	0 Volts	14.5 - 15 Volts

***Test points when isolator used. S2 only used with isolator in system**

7 WIRE CONNECTIONS				
TERM #	TERMINALS	IGNITION OFF	IGNITION ON ENGINE NOT RUNNING	ENGINE RUNNING
3	Reg Term I	0 Volts	2 Volts Approx.	2-10 Volts
7	Reg Term A	12.6 Volts	12.6 Volts	14 Volts
6	Reg Term S	0 Volts	0 Volts	7 Volts Approx.
2	Reg Term F	0 Volts	10-11 Volts	4-11 Volts
4	Reg Term S1	12.6 Volts	12.6 Volts	14 Volts
1	*Reg Term S2	12.6 Volts	12.6 Volts	14 Volts
D	Alt. R/S Term	0 Volts	0 Volts	7 Volts Approx.
C	Alt. F Term	0 Volts	10-11 Volts	4-11 Volts
A	Alt. Pos. Term	12.6 Volts	12.6 Volts	14 Volts
Q	*Isol A Term	0 Volts	0 Volts	14.5 - 15 Volts
P	*Isol B1 Term	12.6 Volts	12.6 Volts	13.5 - 14 Volts
R	*Isol B2 Term	12.6 Volts	12.6 Volts	13.5 - 14 Volts
A	*Alt. Positive term w/Isol.	0 Volts	0 Volts	14.5 - 15 Volts

***Test points when isolator used. S2 only used with isolator in system**

VOLTAGE TEST FOR 10-170/10-172 REGULATOR 23 AND 24 SERIES ALTERNATOR

7 WIRE CONNECTIONS				
TERM #	TERMINALS	IGNITION OFF	IGNITION ON ENGINE NOT RUNNING	ENGINE RUNNING
3	Reg Term I	0 Volts	1.5 - 3 Volts	14 Volts
7	Reg Term A	12.6 Volts	12.6 Volts	14 Volts
6	Reg Term S	0 Volts	0 Volts	7 Volts Approx.
2	Reg Term F	0 Volts	.8 - 2.4 Volts	4-11 Volts
4	Reg Term S1	12.6 Volts	12.6 Volts	14 Volts
1	*Reg Term S2	12.6 Volts	12.6 Volts	14 Volts
D	Alt. R/S Term	0 Volts	0 Volts	7 Volts Approx.
C	Alt. F Term	0 Volts	.8 - 2.4 Volts	4-11 Volts
A	Alt. Pos. Term	12.6 Volts	12.6 Volts	14 Volts
Q	*Isol A Term	0 Volts	0 Volts	14.5 - 15 Volts
P	*Isol B1 Term	12.6 Volts	12.6 Volts	14 Volts
R	*Isol B2 Term	12.6 Volts	12.6 Volts	14 Volts
A	*Alt. Positive term w/Isol.	0 Volts	0 Volts	14.5 - 15 Volts

***Test points when isolator used. S2 only used with isolator in system**

DIAGNOSTIC LED FUNCTIONS

1. **Green** LED is on when "A" Terminal has voltage and internal 5 Volts supply is working
2. **Orange** LED is on when the field terminal is high. It is also on when the ignition is on and the engine is not running.
3. **Yellow** LED is on when engine is running and the alternator is working (7 Volt stator output is present)
4. **Red** LED indicates a low voltage condition the "A" Terminal voltage has dropped below 12.6 Volts

Note: It is normal for Red and Orange LED to flash at low alternator RPM

HOW TO FULL FIELD ALTERNATORS

Full Field 23 & 24 Series at Alternator

1. Remove field/stator plug from alternator (on 23 Series with enclosed brushes remove lead from "F1" (Terminal "C") and tape up (on insulated field models Grd F2 (Terminal "O")).
2. Connect a voltmeter between Terminal "A" (Positive output post) and Terminal "B" (Negative post of alternator ground).
3. Attach A jumper from Terminal "C" (Field Terminal to Positive output post (Terminal "A"). If system had an isolator connect jumper between Terminal "C" and a 12-volt source.
4. Start engine and run at 800 to 1000 RPM's. Alternator voltage should increase to 15-16 volts. If the voltage fails to increase the alternator is bad.
5. If the alternator voltage increases the regulator or wiring harness could be the problem.

Full Field 23 & 24 Series at Regulator

1. Remove the 4 Terminal (or 9 Pin Terminal) plastic plug from regulator.
2. With key on, check brown or green/red lead in harness (Terminal 3), voltage should be from 2 to 10 volts. Check voltage on red or yellow lead in harness (Terminal "7"), this lead must have 12 volts at all times.
3. With engine running at 800-1000 RPM's jump between Terminal position "7" and Terminal position "2" (This is A (#7) and F (#2) position) in plastic plug. The voltage should increase to 15-16 volts on a good alternator and wiring harness. If it works with above test and this test. The problem may be the regulator.
4. If the alternator fails to work but worked with full field at alternator the harness is bad or voltage was not present on A ("7") Terminal.

Fuse in System

1. 10-130 has 20 Amp fuse on regulator. Check fuse if no field current is present.
2. 10-130, 10-170 and 10-172 harnesses have a 20 Amp fuse in Red lead. Check if no field current is present. S1 red/white lead has 5 Amp fuse. Fuse must be good for correct regulator operation. S2 red/yellow lead has a 5 Amp fuse. Fuse must be good for correct auxiliary battery operation.

TEST FOR AMP LOAD ON VEHICLE

Equipment Required to Test Alternator

1. Battery
2. Battery Tester
3. Clamp on Amp meter
5. Photo Electric Tachometer
6. Battery Post Cleaner
7. Jumper Lead with Clips

TEST PROCEDURE

- 1) Test battery to be sure it is full charged and clean cable connections
- 2) Connect voltmeter across positive and negative battery terminals
- 3) Clamp a clamp-on Amp meter over positive battery cable at battery.
- 4) Turn on every load possible with engine not running. Record Amp draw and voltage. If more than one cable, measure each cable's Amp draw and record. Then add all current draws together to get total Amp draw on vehicle.
- 5) Connect voltmeter on positive and negative post of alternator.
- 6) Clamp a clamp-on Amp meter around positive cable at alternator. Start engine. Record voltage and Amps at idle speed.
- 7) Turn on all loads and record voltage and Amps at rear of alternator.
- 8) If load measured at batteries with engine off exceeds Amperage coming out of alternator, increase engine speed until Amperage meets or exceeds the total load that was measured at batteries.
- 9) If engine speed is too high or you are unable to meet the load, the problem may be with pulley ratio or the alternator Amp rating is too small for the load.
- 10) To correct the problem will require a pulley change on the alternator to improve ratio or change both the alternator and pulley to provide more Amps and a better pulley ration.

24 SERIES EXTERNAL RECTIFIED ALTERNATOR

TEST

- 1) To test alternator, remove cables from AC terminals "E", "F" and "G". Remove field stator plug from alternator.
- 2) Connect a jumper from field (Terminal "C") to a 12-volt source. Start engine.
- 3) Engine should be running fast enough to allow the alternator to turn 2000 RPM's.
- 4) Using an AC voltmeter, connect leads between terminals "E" and "F", then between "E" and "G", then between "F" and "G". The AC voltage between the AC terminals should read 26 volts AC plus or minus .5 volt. A difference of 1 volt or more between any of the terminals will indicate a defective stator.
- 5) There should not be any voltage reading from terminals "E", "F" and "G" to alternator case ground.

TROUBLE SHOOT EXTERNAL RECTIFIER PACK

REFER TO DRAWING ON PAGE 13

TOOLS NEEDED: 12-VOLT TEST LITE
12-VOLT VEHICLE BATTERY
VOLT/OHM METER
12-VOLT BATTERY TEST

- STEP 1. DISCONNECT ALL WIRES FROM RECTIFIER PACK
- STEP 2. ATTACH GROUND OF TEST LITE TO BATTERY GROUND. (I)
- STEP 3. ATTACH JUMPER CABLE FROM BATTERY POSITIVE (H) TO POSITIVE BATTERY POST ON RECTIFIER PACK. (M)
- STEP 4. TOUCH TEST LITE TO ALL THREE AC POSTS (J, K, L) ONE AT A TIME. TEST LITE **SHOULD NOT LITE** ON ANY POST.
- STEP 5. ATTACH JUMPER CABLE FROM BATTERY POSITIVE (H) TO NEGATIVE BATTERY POST ON RECTIFIER PACK (N).
- STEP 6. TOUCH TEST LITE TO ALL THREE AC POSTS (J, K, L) ONE AT A TIME. TEST LITE **SHOULD LITE** ON ALL 3 POSTS.
- STEP 7. ATTACH JUMPER CABLE FROM BATTERY POSITIVE TO ALL OF THE THREE PHASE BOLTS (J, K, L) ON RECTIFIER PACK, ONE AT A TIME. TEST LITE **SHOULD LITE** WHEN TOUCHED TO POSITIVE BATTERY POST ON RECTIFIER PACK (M) FOR ALL THREE PHASES.
- STEP 8. REPEAT STEP 7, BUT TOUCH TEST LITE TO NEGATIVE BATTERY POST ON RECTIFIER PACK (N). TEST LITE **SHOULD NOT LITE** WHEN TOUCHED TO NEGATIVE BATTERY POST ON RECTIFIER PACK FOR ALL THREE PHASES.
- STEP 9. WITH METER ON CONTINUITY SETTING, CHECK BETWEEN THE BATTERY BOLT AND THE CASE ON BOTH THE POSITIVE AND NEGATIVE SIDES OF THE RECTIFIER PACK. **THERE SHOULD BE NO READING.**

OHM METER TEST

- STEP 1. SET OHM METER ON DIODE SCALE.
- STEP 2. CONNECT NEGATIVE LEAD TO TERMINAL "M". TOUCH TERMINALS "J", "K", AND "L" WITH POSITIVE LEAD. YOU SHOULD GET A READING.
- STEP 3. CONNECT POSITIVE TERMINAL-TO-TERMINAL "M". TOUCH TERMINALS "J", "K", AND "L". YOU SHOULD NOT GET A READING.
- STEP 4. CONNECT POSITIVE LEAD TO TERMINAL "N". TOUCH TERMINALS "J", "K", AND "L" WITH NEGATIVE LEAD. YOU SHOULD GET A READING.
- STEP 5. CONNECT NEGATIVE LEAD TO TERMINAL "N". TOUCH TERMINALS "J", "K", AND "L" WITH POSITIVE LEAD. YOU SHOULD NOT GET A READING.

NOTE: ON SOME IMPORT OHM METERS, THE RED AND BLACK LEADS ARE REVERSED FOR ABOVE TEST

- STEP 6. CONNECT NEGATIVE LEAD TO GOOD CASE GROUND. TOUCH POSITIVE LEAD TO ALL TERMINALS. YOU SHOULD NOT GET A READING.

ANY DIFFERENCE IN RESULTS OF TESTS COULD INDICATE A FAULTY PRODUCT. CALL FOR TECHNICAL ASSISTANCE AT 1-800-443-9394.

BENCH TEST PROCEDURES

23/24 SERIES ALTERNATOR

A. Items required for test:

1. A variable speed test bench with enough house power to turn alternator at least 8500 RPM. We recommend at least a 20 horsepower drive motor.
2. Heavy duty clamp on Amp meter.
3. Heavy-duty voltmeter.
4. Photoelectric tachometer.

B. Test procedures:

1. Install alternator on test stand.
2. Connect a regulator up to alternator.
3. Connect a voltmeter to positive and negative terminals at alternator.
4. Clamp an Amp meter around positive cable at alternator.
5. Start test stand and stabilize at 2000 alternator RPM's.

C. Test run:

1. Locate correct power curve at rear of this manual for alternator being tested.
2. Run alternator at various speeds and apply loads at various levels against power curves.
MAINTAIN VOLTAGE AT APPROXIMATELY 14.0 VOLTS
3. If unable to get output within 5% of output curve while maintaining the desired voltage, check the **FIELD VOLTAGE**.
4. To check the field voltage, insert a probe into plug on alternator field position. Attach a voltmeter to the probe. Compare the voltage registered here with the voltage, which is read across the positive and negative terminals. At a full load condition the field voltage should read within .5 volts of what is read across positive and negative terminals of the alternator.
5. If field voltage is low it is possible that you have a regulator that will not allow enough field voltage to the rotor and thus a drop in alternator output.
6. If you find step 5 to be the problem, you must full field the alternator. See how to full field on page 33. Results should be an increase in both voltage and Amperage output.
7. If no increase is realized, there is quite possibly a problem inside the alternator. It should be opened up for inspection to determine the nature of the problem.
8. If an increase is realized that indicates a problem with the regulator and it should be replaced.

ISOLATOR TEST

Refer to drawing on page 14

Tools Needed:

12 Volt test light
12 Volt vehicle battery
Volt/OHM meter

TEST USING BATTERY AND TEST LIGHT

- Step 1. Discount all cables from isolator.
- Step 2. Attach lead of test light to battery negative (1).
- Step 3. Attach jumper cable from battery positive (H) to alternator terminal (Q) of isolator.
- Step 4. Touch test light to B1 terminal (P) and to B2 terminal (R) test light should light.
- Step 5. Attach lead of test light to battery positive (H).
- Step 6. Attach jumper cable from battery negative (I) to alternator terminal (Q) of isolator.
- Step 7. Touch test light B1 terminal (P) and to B2 terminal (R) test light should not light.
- Step 8. Attach jumper from battery negative (I) to case ground to isolator (make sure of good connection). Attach test light lead to battery positive (H). Touch test light to terminals "P", "Q", and "R" of isolator. Test light should not light.

TEST USING VOLT/OHM METER

- Step 1. Disconnect all cables from isolator.
- Step 2. Set Volt/OHM meter on diode scale.
- Step 3. Attach positive lead of meter to terminal A (Q) of isolator.
- Step 4. Touch terminals B1 (P) and B2 (R) with negative lead of meter. You should get a reading.
- Step 5. Attach negative lead of meter to terminal A (Q) of isolator.
- Step 6. Touch terminals B1 (P) and B2 (R) with positive lead of meter. You should not get a reading.
- Step 7. Attach positive lead of meter to case of isolator. Touch terminals "P", "Q", and "R". You should not get a reading.

Note: On some import OHM meters the red and black leads are reversed for above test.

TEST USING VOLT/OHM METER

- Step 1. Disconnect all cables from isolator.
- Step 2. Set volt/OHM meter on diode scale.
- Step 3. Attach terminals B1 (P) and B3 (R) with negative lead of meter. You should get a reading.
- Step 4. Touch terminals B1 (P) and B3 (R) with negative lead of meter. You should get a reading.

FINDING PULLEY RATIO

The correct pulley ratio is very important for correct alternator performance.

1. A pulley ratio of 3 to 1 is preferred, or a ratio as close to 3 to 1 as possible. It is recommended not to use a ratio less than 2.5 to 1.
2. To find the pulley ratio: Measure the diameter of the crankshaft pulley (or the pulley driving the alternator) and the diameter of the alternator pulley.

Note: Measure V belt pulleys on total outside diameter.

Measure serpentine belt pulleys across the top of the grooves the belt rides on.

3. Divide the diameter of the crankshaft pulley by the diameter of the alternator pulley. This will give you the pulley ratio.
4. On engines with an alternator driven off an accessory drive it is necessary to use a photo tachometer to figure ratios. *
5. To find the ratio using a photo tachometer: Measure the speed of the crankshaft pulley. Measure the speed of the alternator pulley. Divide the alternator pulley speed by the crankshaft pulley speed; this will give you the ratio.
6. To find alternators current capability at any given RPM refer to the alternator power curves in this book. Page 41 thru 44.

Note: The power curves show alternator RPM, you must multiply engine RPM by ratio to get alternator speed.

* Sometimes the alternator is driven by a pulley other than the crankshaft, and that drive pulley sometimes is designed to run at 2 to 2 ½ times the engine crankshaft speed: in these instances call 800-433-9394 for assistance.

RECOMMENDED BATTERY CABLE SIZE (AS A FUNCTION OF CURRENT AND LENGTH)

SYSTEM VOLTAGE	RATED OUTPUT (AMPS)	MINIMUM SIZE CABLE TO USE (AWG)					
		UP TO 5 FT.	5-10 FT.	10-15 FT.	15-20 FT.	20-25 FT.	25-30 FT.
12 VOLT	0-60	8 AWG	4 AWG	2 AWG	2 AWG	1 AWG	0 AWG
	60-100	6 AWG	4 AWG	1 AWG	0 AWG	0 AWG	2/0 AWG
	100-150	4 AWG	2 AWG	0 AWG	2/0 AWG	2/0 AWG	3/0 AWG
	150-190	4 AWG	1 AWG	2/0 AWG	3/0 AWG	4/0 AWG	4/0 AWG
	190-250	2 AWG	0 AWG	2/0 AWG	4/0 AWG	4/0 AWG	4/0 AWG
	250-300	0 AWG	2/0 AWG	3/0 AWG	4/0 AWG	4/0 AWG	4/0 AWG
24 VOLT	0-30	14 AWG	14 AWG	10 AWG	8 AWG	8 AWG	6 AWG
	30-50	12 AWG	10 AWG	8 AWG	6 AWG	6 AWG	4 AWG
	50-75	10 AWG	8 AWG	6 AWG	4 AWG	4 AWG	2 AWG
	75-100	6 AWG	6 AWG	4 AWG	4 AWG	2 AWG	1 AWG
	100-125	4 AWG	4 AWG	4 AWG	2 AWG	2 AWG	1 AWG
	125-150	2 AWG	2 AWG	1 AWG	1 AWG	0 AWG	0 AWG

CONVERSION OF WIRE SIZES			
AWG	METRIC (MM ²)	AWG	METRIC (MM ²)
14	2	2	32
12	3	1	40
10	5	0	50
8	8	2/0	62
6	13	3/0	81
4	19	4/0	103

NOTE

1. Cable length must include both positive and negative cables.
2. Maximum acceptable voltage drop = 0.5 volts in a 12 volt system or 1.0 volts in a 24 system with ambient temperature surrounding cables is 150°F or less.

SERIES 23, 100 AMP, 12V

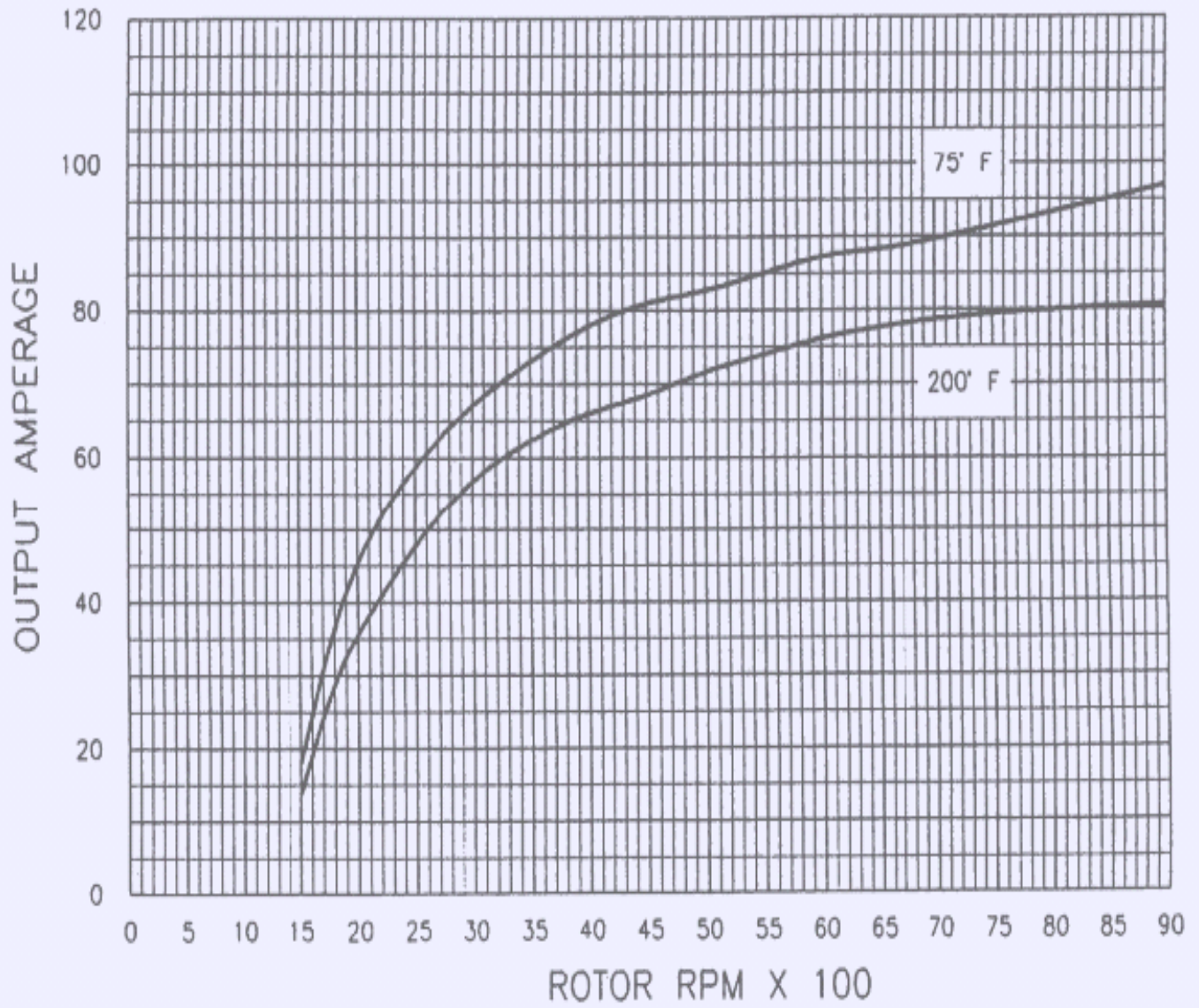

SERIES 23, 120 AMP, 12V

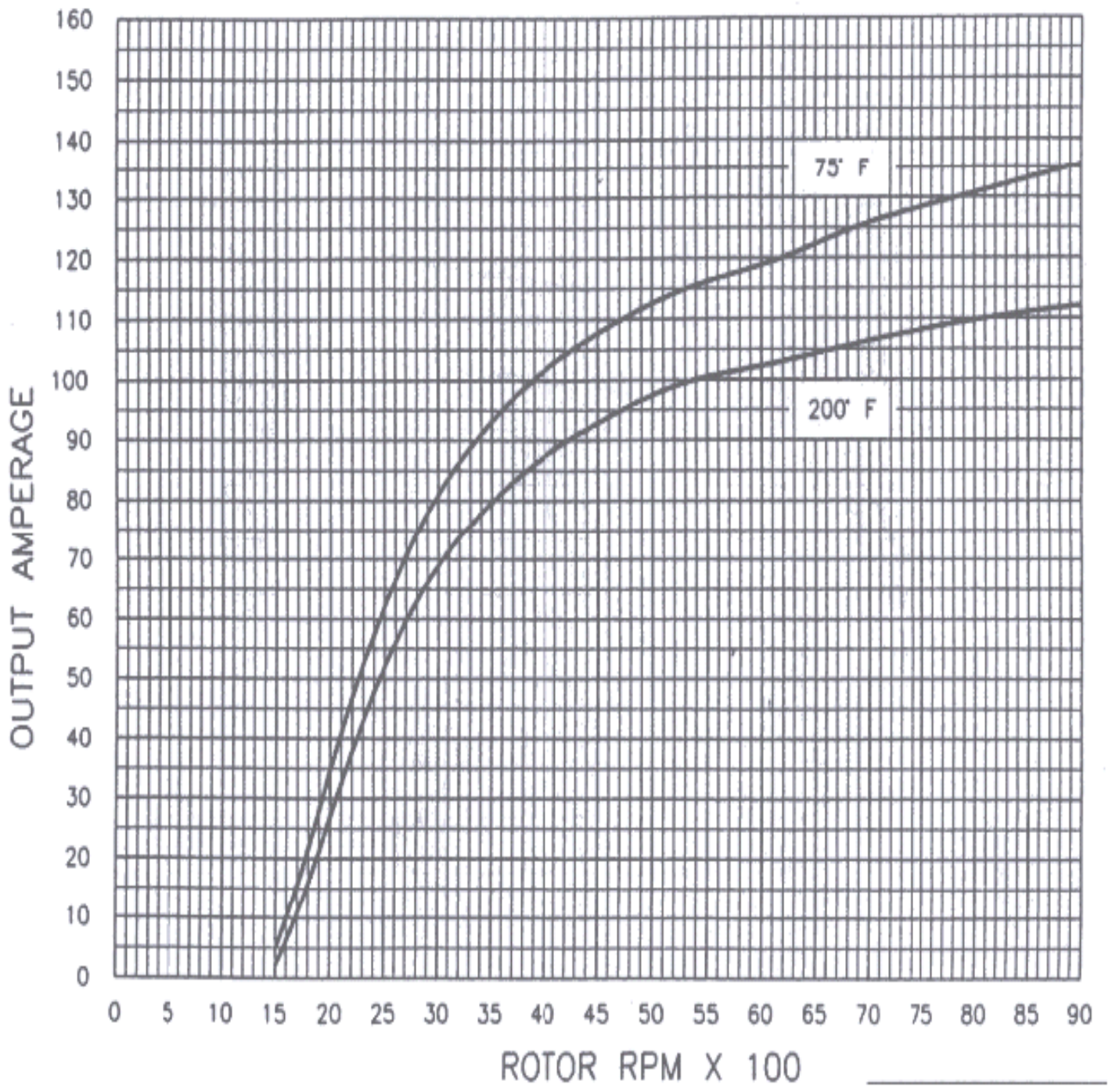

Series 23, ULA MARINE, 120 AMP, 12V

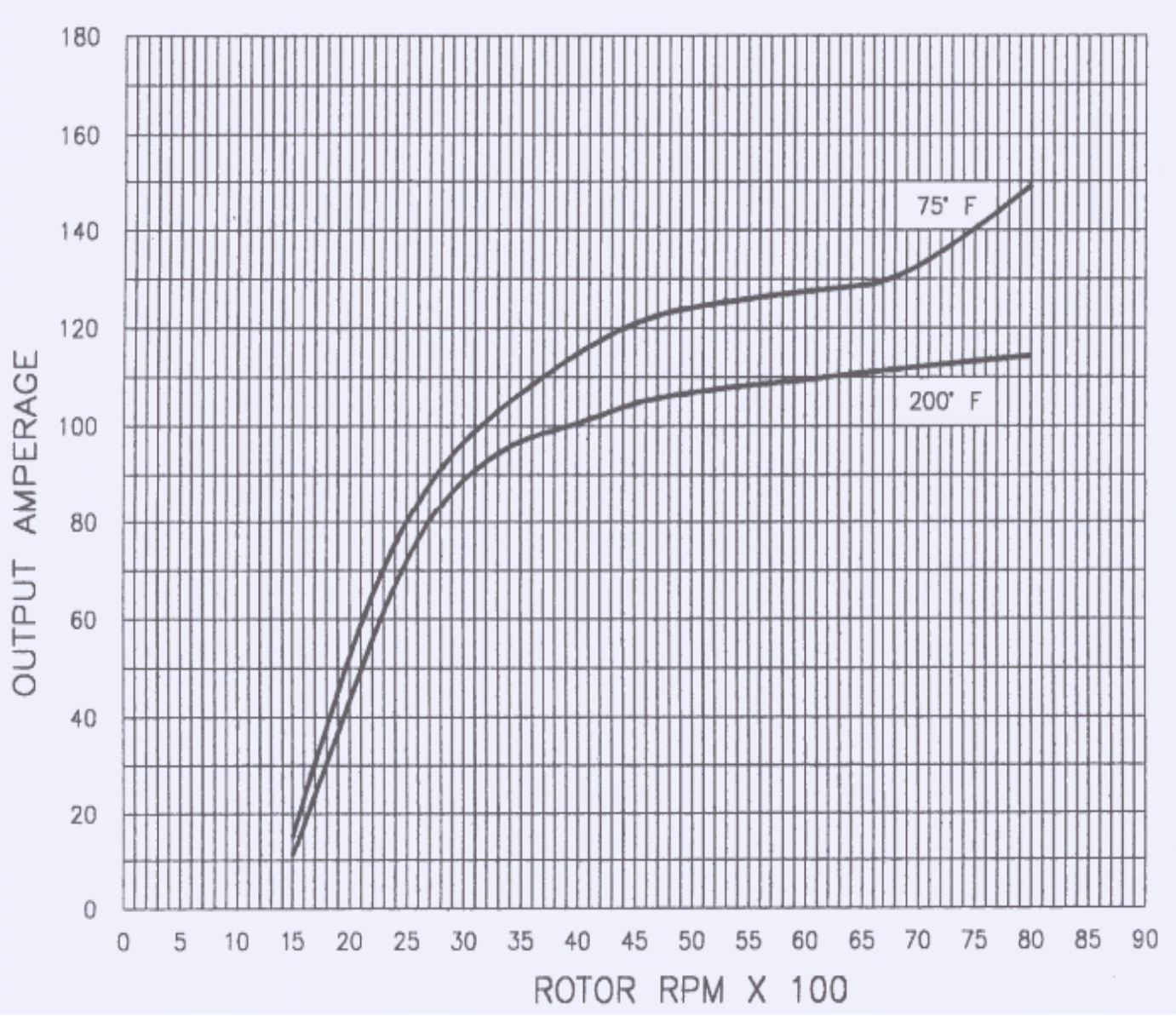

SERIES 23, 150 AMP, 12V

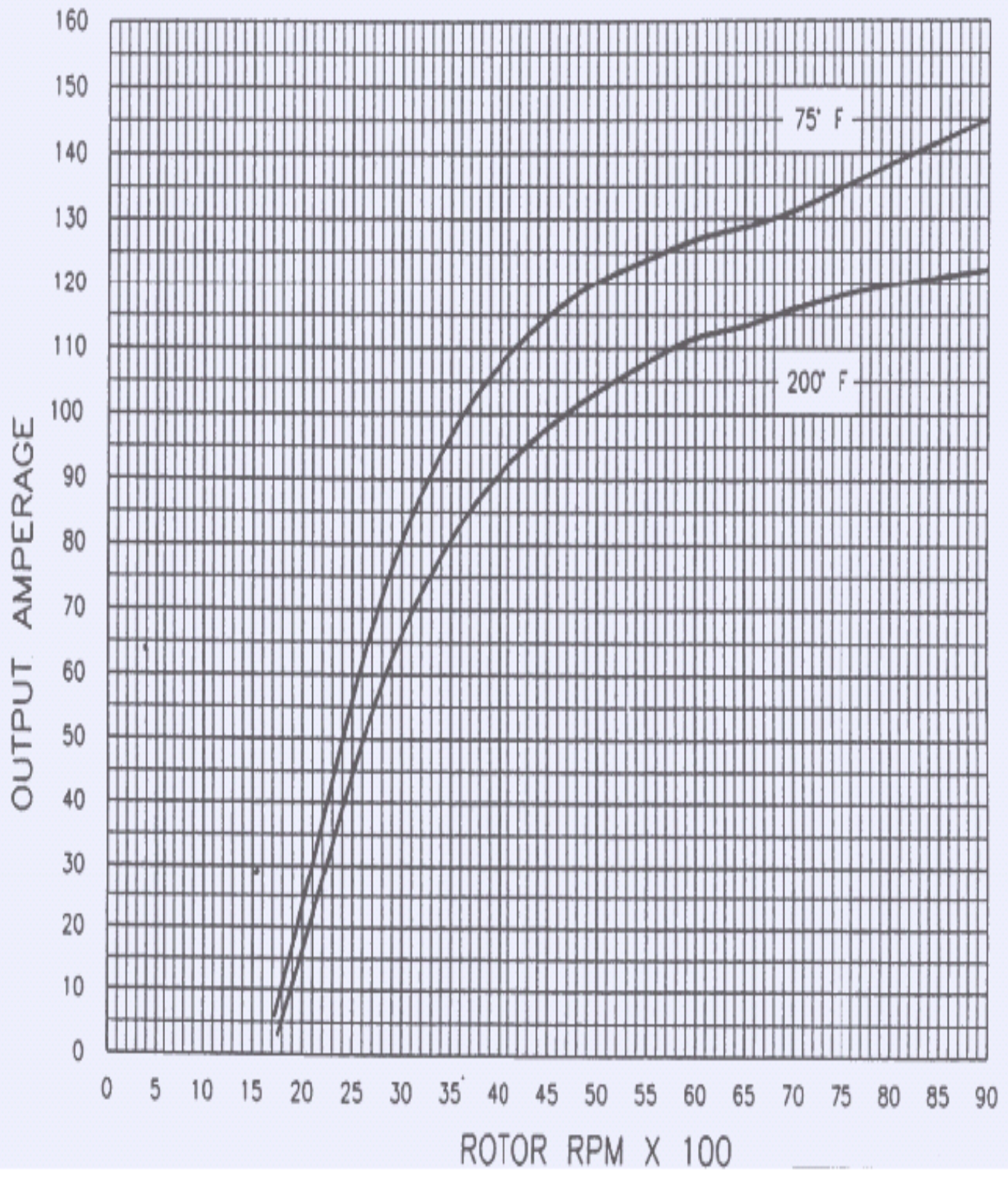

SERIES 24, 100 AMP, 24V

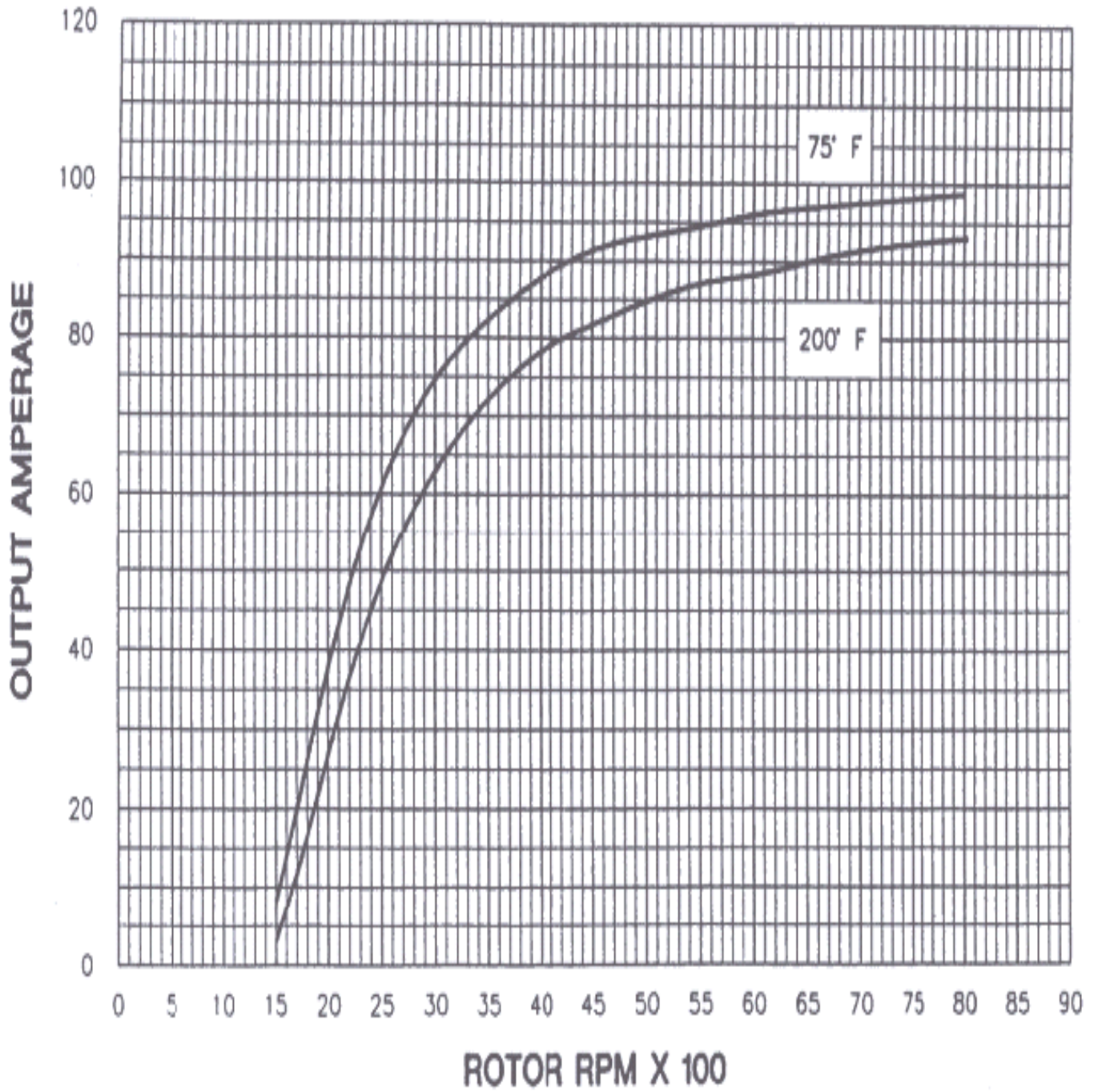

SERIES 24, 160 AMP, 12V

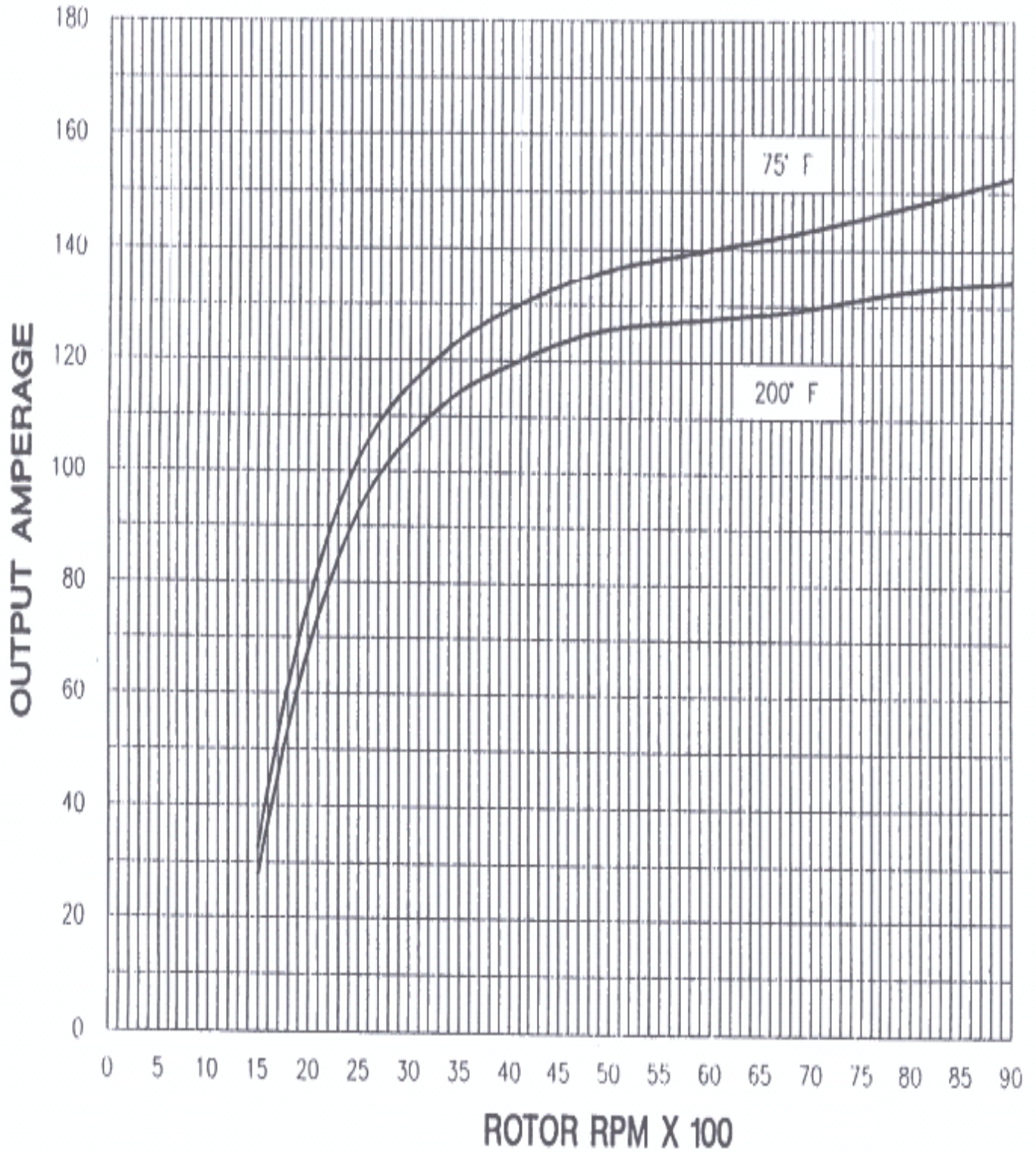

SERIES 24, 190 AMP, 12V

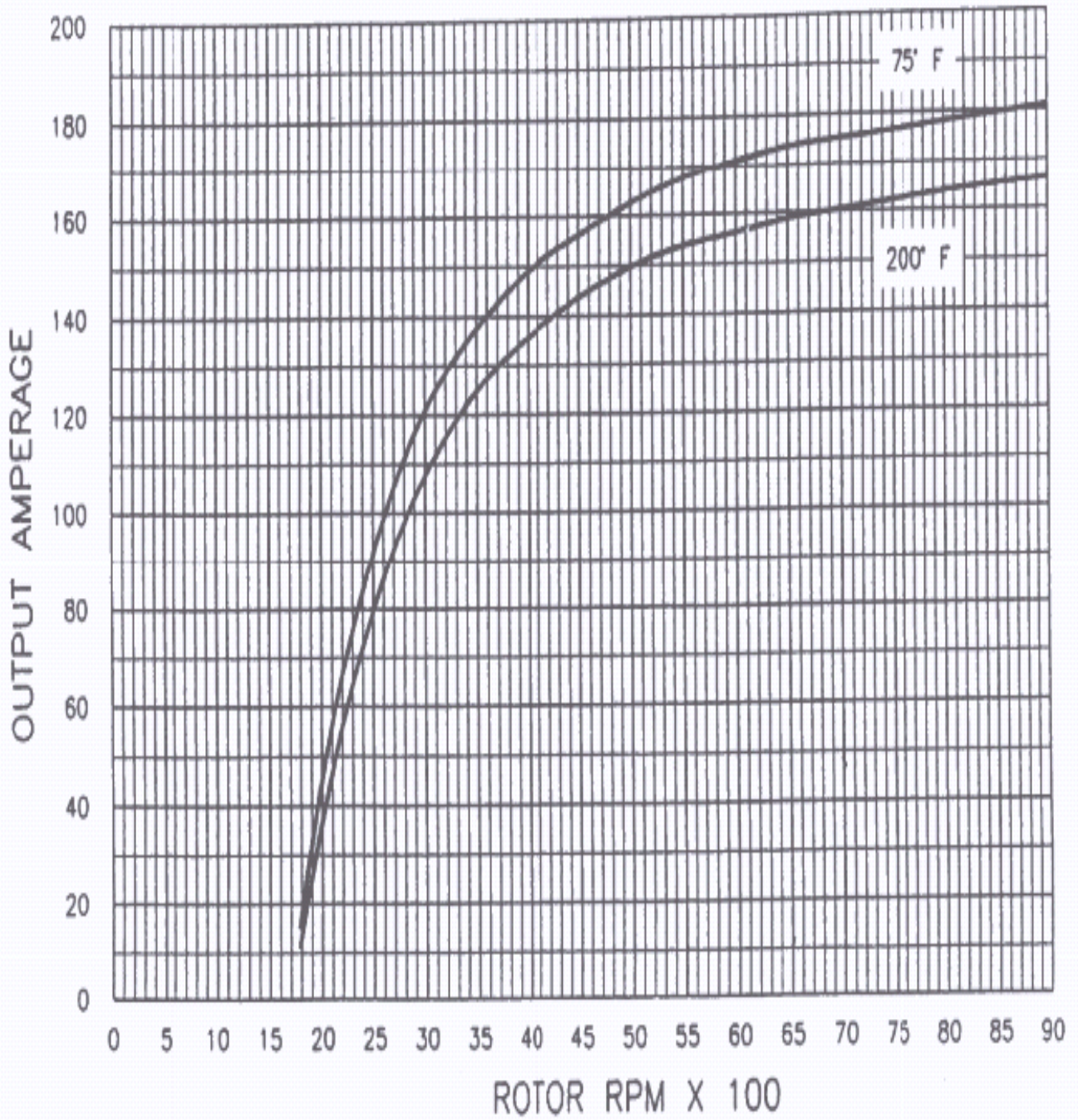

SERIES 24, 220 AMP, 12V

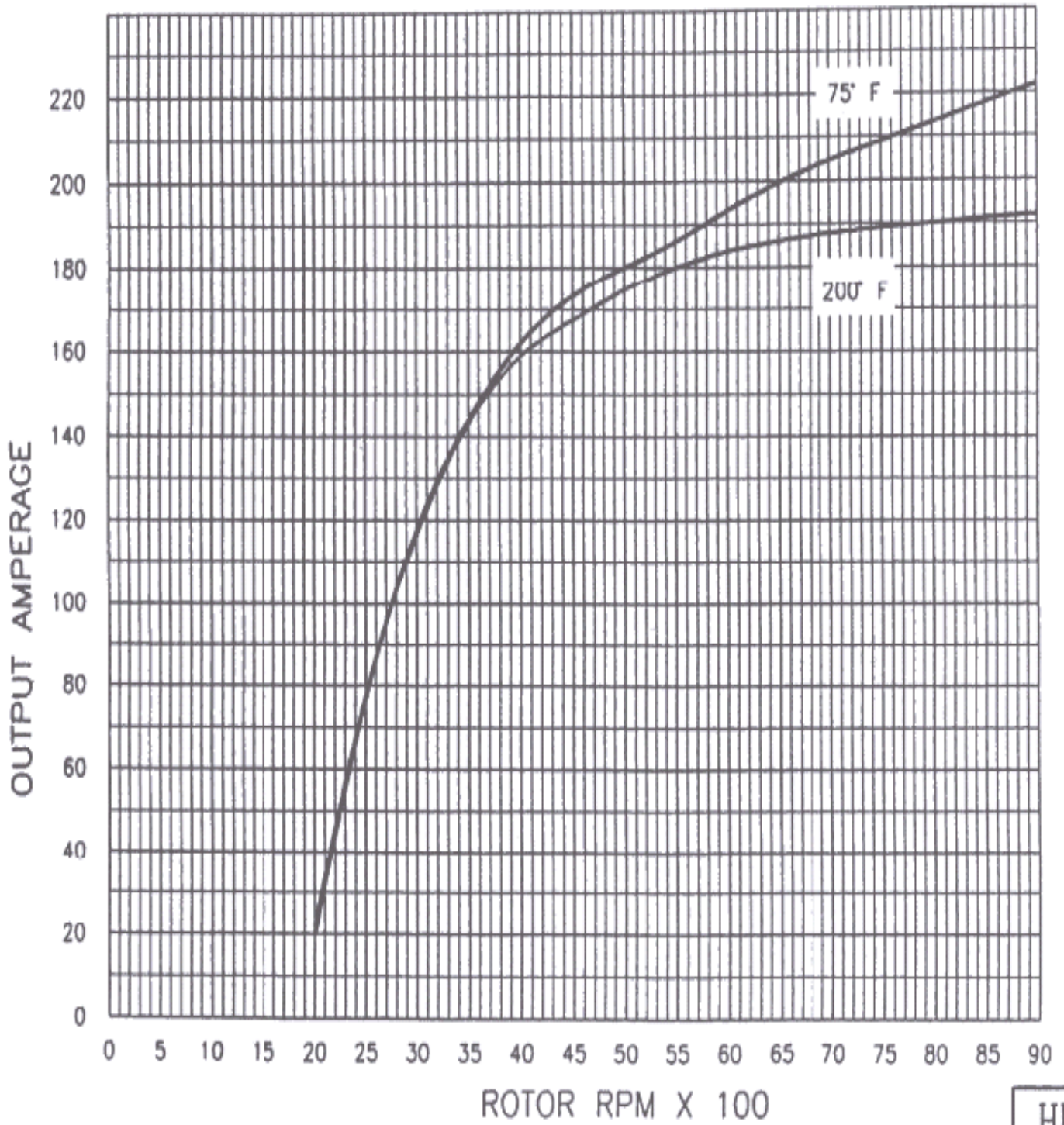

HEI

MISCELLANEOUS ALTERNATOR INFORMATION

FIELD VOLTAGE

LOAD	12 VOLTS	24 VOLTS
LIGHT LOAD	1-4 VOLTS	2-8 VOLTS
MEDIUM LOAD	5-9 VOLTS	10-18 VOLTS
HEAVY LOAD	10-13.5 VOLTS	20-28 VOLTS

FIELD CURRENT MAXIMUM DRAW

SERIES	AMPS	VOLTS
23	4.5-5	12.6
23 ENCLOSED BRUSH MODEL	5.5-6	12.6
24	5.5-6	12.6
24	5-5.5	25.2

ROTOR OHMS

SERIES	OHMS
23 12 VOLT	2.5-2.8
23 ENCLOSED BRUSH MODEL	2.1-2.2
24 12 VOLT	1.9-2.2
24 24 VOLT	4.5-4.7

MEASURE ACROSS SLIP RINGS

NUMBER OF POLES ON ROTOR

SERIES	POLES
23	14
24	12

24 SERIES 24 VOLT VOLTAGE TEST

VOLTAGE TEST FOR 10-9

3 WIRE CONNECTION				
TERM #	TERMINALS	IGNITION OFF	IGNITION ON ENGINE NOT RUNNING	ENGINE RUNNING
3	Reg Term I	-----	Not Used	-----
7	Reg Term A	24.5 - 25 Volts	24.5 - 25 Volts	27 - 29 Volts
6	Reg Term S	0 Volts	24.5 - 25 Volts	26 - 28 Volts
2	Reg Term F	0 Volts	22 - 23.5 Volts	10 - 23.5 Volts
D	Alt Term R/S	0 Volts	0 Volts	13.5 to 14.5 Volts
C	Alt Term F	0 Volts	22 - 23.5 Volts	10 - 23.5 Volts
A	Alt Pos. Term	24.5 - 25 Volts	24.5 - 25 Volts	27 - 29 Volts
Q	*Isol A Term	0 Volts	0 Volts	28 - 30 Volts
P	*Isol B1 Term	24.5 - 25 Volts	24.5 - 25 Volts	27 - 29 Volts
R	*Isol B2 Term	24.5 - 25 Volts	24.5 - 25 Volts	27 - 29 Volts
A	*Alt Pos. w/ Isol	0 Volts	0 Volts	28 - 30 Volts

VOLTAGE TEST FOR 10-129

6 WIRE CONNECTION NO LAMP USED				
TERM #	TERMINALS	IGNITION OFF	IGNITION ON ENGINE NOT RUNNING	ENGINE RUNNING
3	Reg Term I	-----	Not Used	-----
7	Reg Term A	24.5 - 25 Volts	24.5 - 25 Volts	27 - 29 Volts
6	Reg Term S	0 Volts	24.5 - 25 Volts	26 - 28 Volts
2	Reg Term F	0 Volts	22 - 23.5 Volts	10 - 23.5 Volts
4	Reg Term S1	24.5 - 25 Volts	24.5 - 25 Volts	27 - 29 Volts
1	*Reg Term S2	24.5 - 25 Volts	24.5 - 25 Volts	27 - 29 Volts
D	Alt Term R/S	0 Volts	0 Volts	13.5 to 14.5 Volts
C	Alt Term F	0 Volts	22 - 23.5 Volts	10 - 23.5 Volts
A	Alt Pos. Term	24.5 - 25 Volts	24.5 - 25 Volts	27 - 29 Volts
Q	*Isol A Term	0 Volts	0 Volts	28 - 30 Volts
P	*Isol B1 Term	24.5 - 25 Volts	24.5 - 25 Volts	27 - 29 Volts
R	*Isol B2 Term	24.5 - 25 Volts	24.5 - 25 Volts	27 - 29 Volts
A	*Alt Pos. w/ Isol	0 Volts	0 Volts	28 - 30 Volts

VOLTAGE TEST FOR 10-175

7 WIRE CONNECTION				
TERM #	TERMINALS	IGNITION OFF	IGNITION ON ENGINE NOT RUNNING	ENGINE RUNNING
3	Reg Term I (Note 4)	0 Volts	20 - 25 Volts	24 - 27 Volts
7	Reg Term A	24.5 - 25 Volts	24.5 - 25 Volts	27 - 29 Volts
6	Reg Term S (Note 5)	0 Volts	0 Volts	13.5 to 14.5 Volts
2	Reg Term F	0 Volts	24 - 23.5 Volts	24 - 23.5 Volts
4	Reg Term S1	24.5 - 25 Volts	24.5 - 25 Volts	27 - 29 Volts
1	*Reg Term S2	24.5 - 25 Volts	24.5 - 25 Volts	27 - 29 Volts
D	Alt Term R/S	0 Volts	0 Volts	13.5 to 14.5 Volts
C	Alt Term F	0 Volts	24 - 23.5 Volts	24 - 23.5 Volts
A	Alt Pos. Term	24.5 - 25 Volts	24.5 - 25 Volts	27 - 29 Volts
Q	*Isol A Term	0 Volts	0 Volts	28 - 30 Volts
P	*Isol B1 Term	24.5 - 25 Volts	24.5 - 25 Volts	27 - 29 Volts
R	*Isol B2 Term	24.5 - 25 Volts	24.5 - 25 Volts	27 - 29 Volts
A	*Alt Pos. w/ Isol	0 Volts	0 Volts	28 - 30 Volts

- Note 1.** *Test points when isolator is used.
Note 2. Terminal 1, "S2" only used with isolator in system.
Note 3. All voltages are approximate.
Note 4. Can use 28 volt lamp in this circuit if needed.

Reg I Term	Ign Off 0 Volts	24.5 - 25 Volts	24.5 - 25 Volts	27 - 29 Volts
------------	-----------------	-----------------	-----------------	---------------

- Note 5.** Stator must be connected for proper operation to stator terminal of alternator only.

DO NOT CONNECT D.C. TO THIS TERMINAL

GASKET INSTALLATION

23 SERIES ENCLOSED BRUSH MODEL

THE WHITE FELT GASKET USED BETWEEN THE ALTERNATOR AND THE FIELD COVER PLATE IS AN IMPORTANT PART OF THE ALTERNATOR. WHEN PROPERLY INSTALLED, IT WILL ENSURE THAT THE ARCING BETWEEN THE BRUSHES AND THE SLIP RING WILL NOT IGNITE AN EXPLOSIVE FUEL MIXTURE WHICH MAY BE PRESENT IN THE GASOLINE ENGINE COMPARTMENT OF A BOAT IF THE COMPARTMENT IS NOT PROPERLY VENTED.

THE FOLLOWING PROCEDURE MUST BE USED WHEN REPLACING THE GASKET WITH THE ALTERNATOR ON A WORK BENCH

1. REMOVE THE FIELD COVER PLATE FROM THE ALTERNATOR. SAVE ALL THE HARDWARE AS THIS IS REQUIRED FOR REINSTALLATION.
2. DISCARD THE OLD GASKET. DO NOT REUSE!
3. REMOVE ANY PIECES OF THE OLD GASKET FROM THE ALTERNATOR AND THE FIELD COVER AS SHOWN IN THE ILLUSTRATION.
4. POSITION THE NEW GASKET ON THE PINS ON THE FIELD COVER CASING. BE SURE THAT THE NEW GASKET IS FULLY SEATED.
5. REINSTALL THE FIELD COVER ON TO THE ALTERNATOR, MAKING SURE TO RECONNECT THE LEADS TO THE BRUSH TERMINALS INSIDE.
6. RECONNECT THE FIELD COVER LEADS TO THE APPROPRIATE TERMINALS ON THE ALTERNATOR.
7. RETEST THE ALTERNATOR PRIOR TO ITS BEING REINSTALLED ON THE ENGINE.

NOTE:

POSITION THESE HOLES IN THE GASKET OVER THE PINS ON THE CASTING

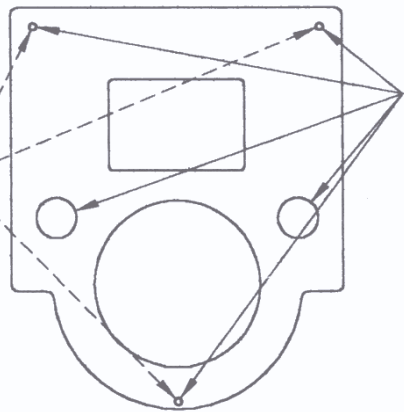

REMOVE ANY MATERIAL FROM THESE AREAS BEFORE INSTALLATION OF THE NEW GASKET

THANK YOU FOR CHOOSING

POWERLINE