



OCEAN SAFETY®

Ocean Safety Ocean ISO Liferaft Service Manual



DATE:	31/10/2020	CREATED BY:	P. Marlow
ISSUE:	02/2020	CHECKED BY	J.Beaumont

Private & Confidential:

This document and the design depicted is the Property of Ocean Safety Limited. It is provided on the express terms that it must be treated as confidential and is not to be copied or communicated to any other party without written permission from Ocean Safety.

Section:	Introduction to Manual			
DATE:	31/10/2020	CREATED BY:	P.Marlow	
ISSUE:	02/2020	CHECKED BY	J.Beaumont	

Contents:

Section 1 ~ Introduction

Section 2 ~ Liferaft Description Classification & Data

Section 3 ~ Disassembly & Inspection

Section 4 ~ Testing

Section 5 ~ Remedial Action & Repairs

Section 6 ~ Assembly & Packing

Section 7 ~ UltraLite Assembly & Packing

Section 8 ~ Service Information & Data Labels

Section 9 ~ Spare Parts

Section:	Introduction to Manual			
DATE:	31/10/2020	CREATED BY:	P.Marlow	
ISSUE:	02/2020	CHECKED BY	J.Beaumont	

Maintenance and Control of Manual

Ocean Safety has a policy of continual development and improvements for the design of the Ocean ISO / Ocean ISO Ultralite Liferaft range. Where required the manual will be updated to reflect changes. To this end updates to the manual will be issued.

At the beginning of each section of the manual there is a copy of the table below. Any changes to the manual shall be documented in the relevant section in the table provided.

Once sections of the manual have been removed and replaced; the old copy shall be destroyed to avoid confusion in future service intervals.

Revision N°	Sections Affected	Issue Date	Inserted Date	Signature
02/2020	Complete update including the Mk2 container & the relevant enhancements	31/10/2020	31/10/2020	P.Marlow

Section:	Introduction to Manual			
DATE:	31/10/2020	CREATED BY:	P.Marlow	
ISSUE:	02/2020	CHECKED BY	J.Beaumont	

Section ~ 1

Introduction

Ocean ISO / Ocean ISO Ultralite Liferafts

Including Mk1 & Mk2 Containers

Section:	Introduction to Manual			
DATE:	31/10/2020	CREATED BY:	P.Marlow	
ISSUE:	02/2020	CHECKED BY	J.Beaumont	

1 ~ Introduction

1.1 ~ Introduction to Manual

1.2 ~ Scope

1.3 ~ Definition of Terms

1.4.1 ~ Warnings

1.4.2 ~ Cautions

1.4.3 ~ Notes

Section:	Introduction to Manual			
DATE:	31/10/2020	CREATED BY:	P.Marlow	
ISSUE:	02/2020	CHECKED BY	J.Beaumont	

1.1 ~ Introduction to Manual

This manual has been compiled as a descriptive guide to the Scheduled / Periodic service and maintenance of the Ocean ISO / OceanISO Ultralite liferaft range including the Mk1 & Mk2 containers.

The information contained within this manual is for the use of approved service stations appointed and trained by Ocean Safety for the sole purpose of servicing and maintaining the Ocean ISO / ISO Ultralite Liferaft range and approved variations.

The manual includes all the modifications, which includes the new design Mk2 containers, the vacuum bag replacement & how to convert the older Ocean ISO liferafts to allow the extension of the servicing period..

1.2 ~ Scope

The manual details the required information and procedures to service the Ocean Safety Ocean ISO liferaft range and emergency packs up to the standard prescribed by ISO 9650 parts 1 & 3.

The range encompasses liferaft sizes 4, 6, 8, 10 and 12 person liferafts in valise or container format depending on approved variations. Emergency packs comprise of ISO pack 1 >24 hour, Pack 2 < 24 hour and SOLAS B pack Plus approved variations

1.3 ~ Definition of Terms

1.3.1 ~ Warnings

Warnings indicate a procedure that if not completed correctly could result in injury or fatality of service personal or persons using or handling the liferaft

1.3.2 ~ Cautions

Cautions indicate a procedure that if not completed correctly could results in damage to mechanical parts or the fabric of the liferaft.

1.3.3 ~ Notes

Notes are methods to aid service engineers through the procedures and make specific jobs easier.

Section:	Liferaft Description Classification and Data			
DATE:	31/10/2020	CREATED BY:	P.Marlow	
ISSUE:	02/2020	CHECKED BY	J.Beaumont	

Section ~ 2

Liferaft Description Classification & Data

Ocean ISO / Ocean ISO Ultralite Liferafts

Including Mk1 & Mk2 Containers

Section:	Liferaft Description Classification and Data			 OCEAN SAFETY®
DATE:	31/10/2020	CREATED BY:	P.Marlow	
ISSUE:	02/2020	CHECKED BY	J.Beaumont	

Section 2 ~ Liferaft Description Classification and Data

All modifications to the following sections shall be recorded in the table provided below. Once a new section is issued, replace the old version of the manual and destroy the obsolete pages.

Revision N°	Sections Affected	Issue Date	Inserted Date	Signature
Rev 0109	2.2 Emergency packs	02.06.09		C.Perks
Rev 1010	2.2.1 to 2.5	07.10.10		C.Perks
Rev 0612	2.1 to 2.3 and 2.5	27.06.12		J.Beaumont
02/2020	Complete update including the Mk2 container & the relevant enhancements	31/10/2020	31/10/2020	P.Marlow

Section:	Liferaft Description Classification and Data			
DATE:	31/10/2020	CREATED BY:	P.Marlow	
ISSUE:	02/2020	CHECKED BY	J.Beaumont	

2 ~ Liferaft Description Classification and Data

2.1 ~ Ocean ISO Design Details

- 2.1.1 ~ 4 Person
- 2.1.2 ~ 6 Person
- 2.1.3 ~ 8 Person
- 2.1.4 ~ 10 Person
- 2.1.5 ~ 12 person

2.2 ~ Emergency Packs

- 2.2.1 ~ ISO Pack 2, Less than 24 Hours Pack
- 2.2.2 ~ ISO Pack1, Greater than 24 Hours Pack
- 2.2.3 ~ SOLAS B Pack
- 2.2.4 ~ Australian Regulation Equipment Pack
- 2.2.5 ~ Ocean ISO Ultralite Pack

2.3 ~ Cylinders & Inflation systems

- 2.3.1 ~ Ocean ISO Mk1, Cylinders
- 2.3.2 ~ Ocean ISO Mk2, Cylinders
- 2.3.3 ~ Ocean ISO Inflation System
- 2.3.4 ~ Ocean ISO Ultralite Inflation System

2.4 ~ Container & Valise Details

- 2.4.1 ~ Ocean ISO Mk1 Containers - Pre 2020
- 2.4.2 ~ Ocean ISO Mk2 Containers - Post 2020
- 2.4.3 ~ Ocean ISO Valise

Section:	Liferaft Description Classification and Data			 OCEAN SAFETY®
DATE:	31/10/2020	CREATED BY:	P.Marlow	
ISSUE:	02/2020	CHECKED BY	J.Beaumont	

2.1 ~ Ocean ISO Design Details

2.1.1 ~ 4 Person

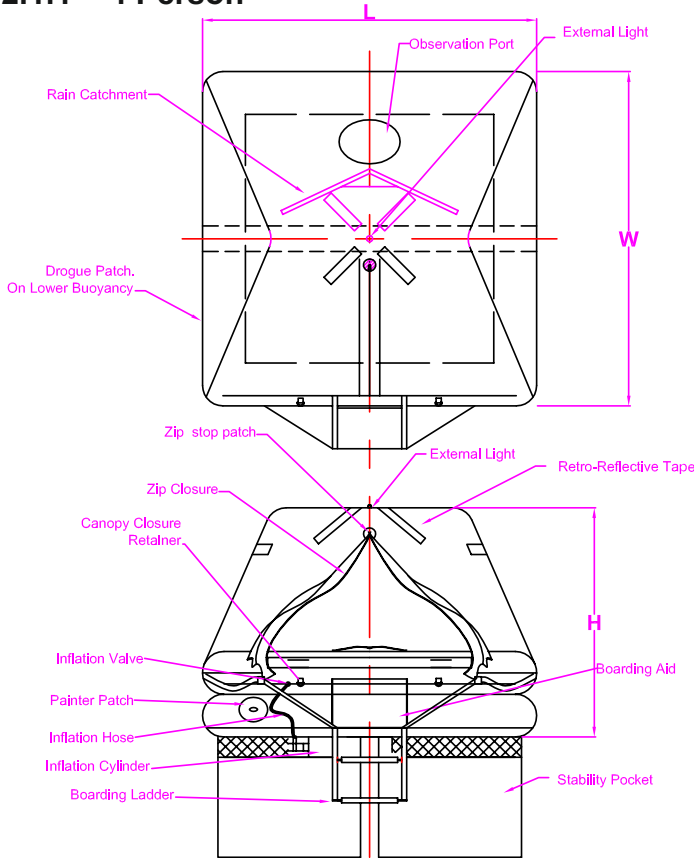

Data 4 Person. ISO 9650 Type 1 Drawing No. OS/ISO104P-00

Dimensions = 164cm(L) x 164cm(W) x 112.5cm(H)

Internal. (Not shown).

1. Internal Light.
2. Internal Lifeline.
3. Boarding Aid - See Drawing No.OS/ISOIBA-00
4. Rescue Line & Quoit.
5. Knife
6. Inflation Valves.
7. Inflatable Floor.
8. Arch Tube.
9. Arch Tube Inflation Valve.
10. Emergency Pack & Attachments.
11. Labels.

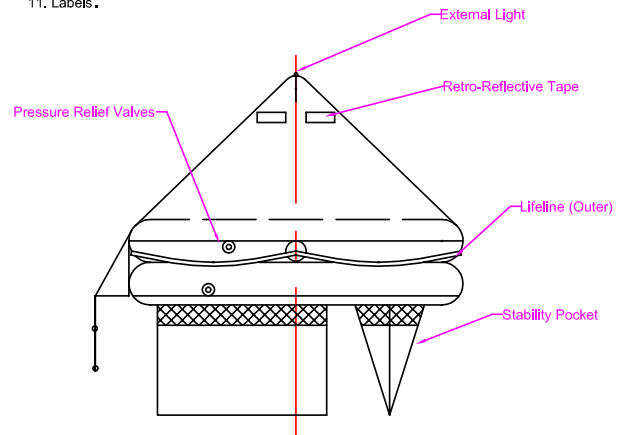

2.1.2 ~ 6 Person

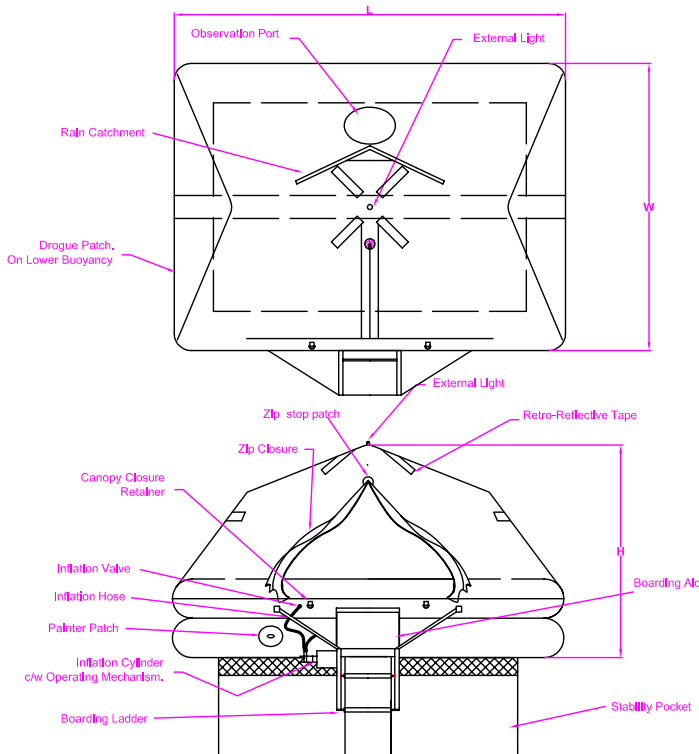



Data. 6 Person. ISO 9650 Type 1 Drawing Number OS/ISO106P-00

Dimensions = 168(W)cm x 229cm(L) x 124.3cm(H).

Internal. (Not shown).

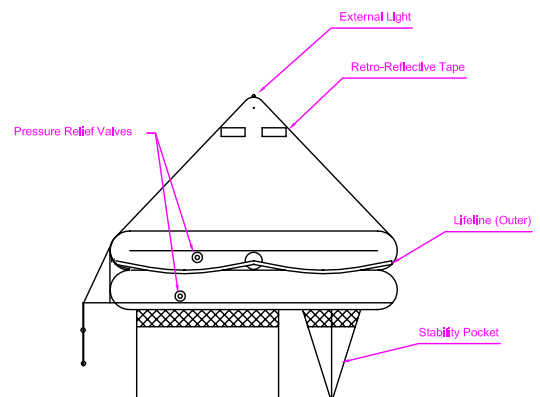
1. Internal Light.
2. Internal Lifeline.
3. Boarding Aid - See Drawing No. OS/ISOIBA-00
4. Rescue Line & Quoit.
5. Knife
6. Inflation Valves.
7. Inflatable Floor.
8. Arch Tube.
9. Arch Tube Inflation Valve.
10. Emergency Pack & Attachments.
11. Labels.



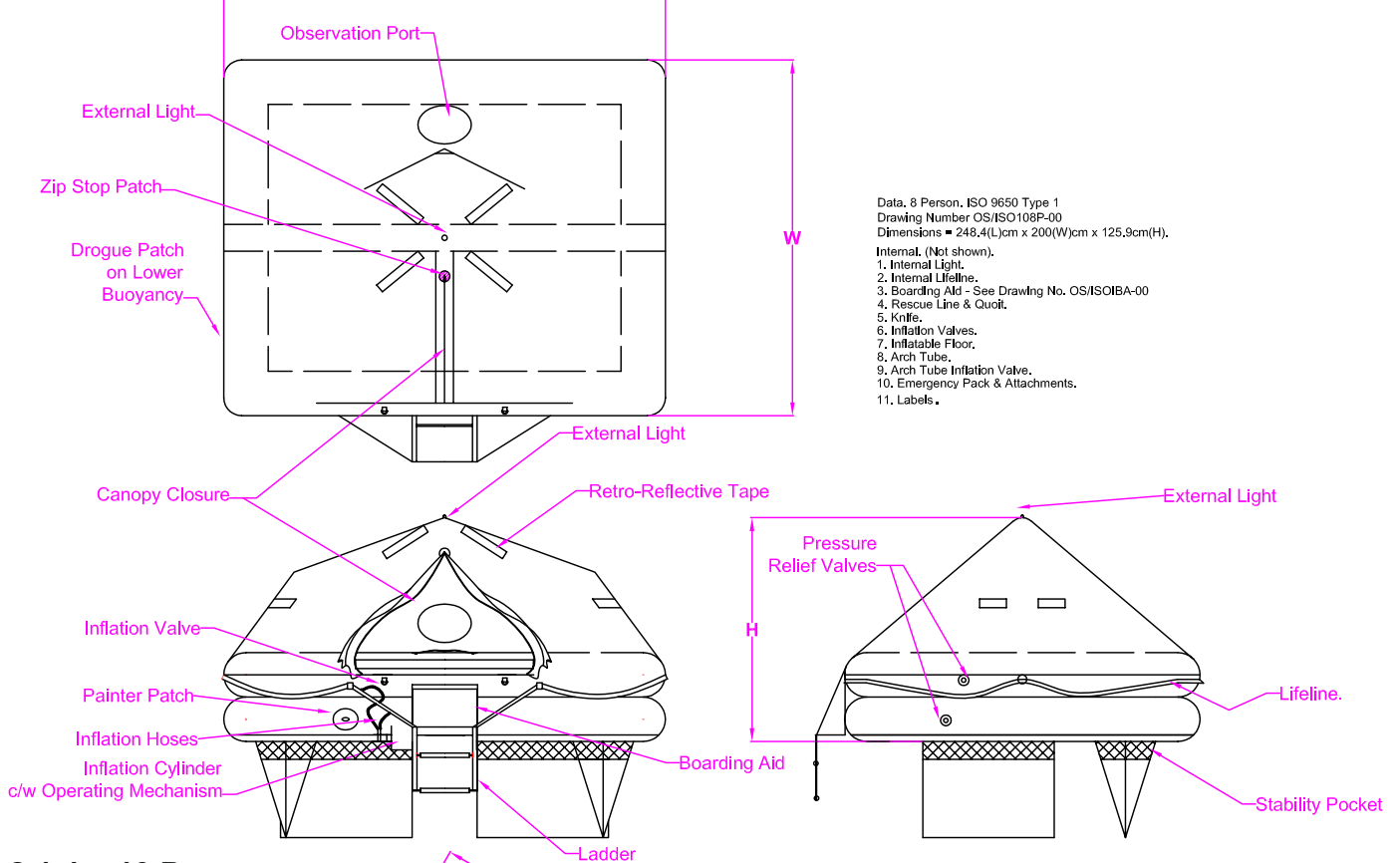

Section:	Liferaft Description Classification and Data			 OCEAN SAFETY®
DATE:	31/10/2020	CREATED BY:	P.Marlow	
ISSUE:	02/2020	CHECKED BY	J.Beaumont	

2.1.3 ~ 8 Person

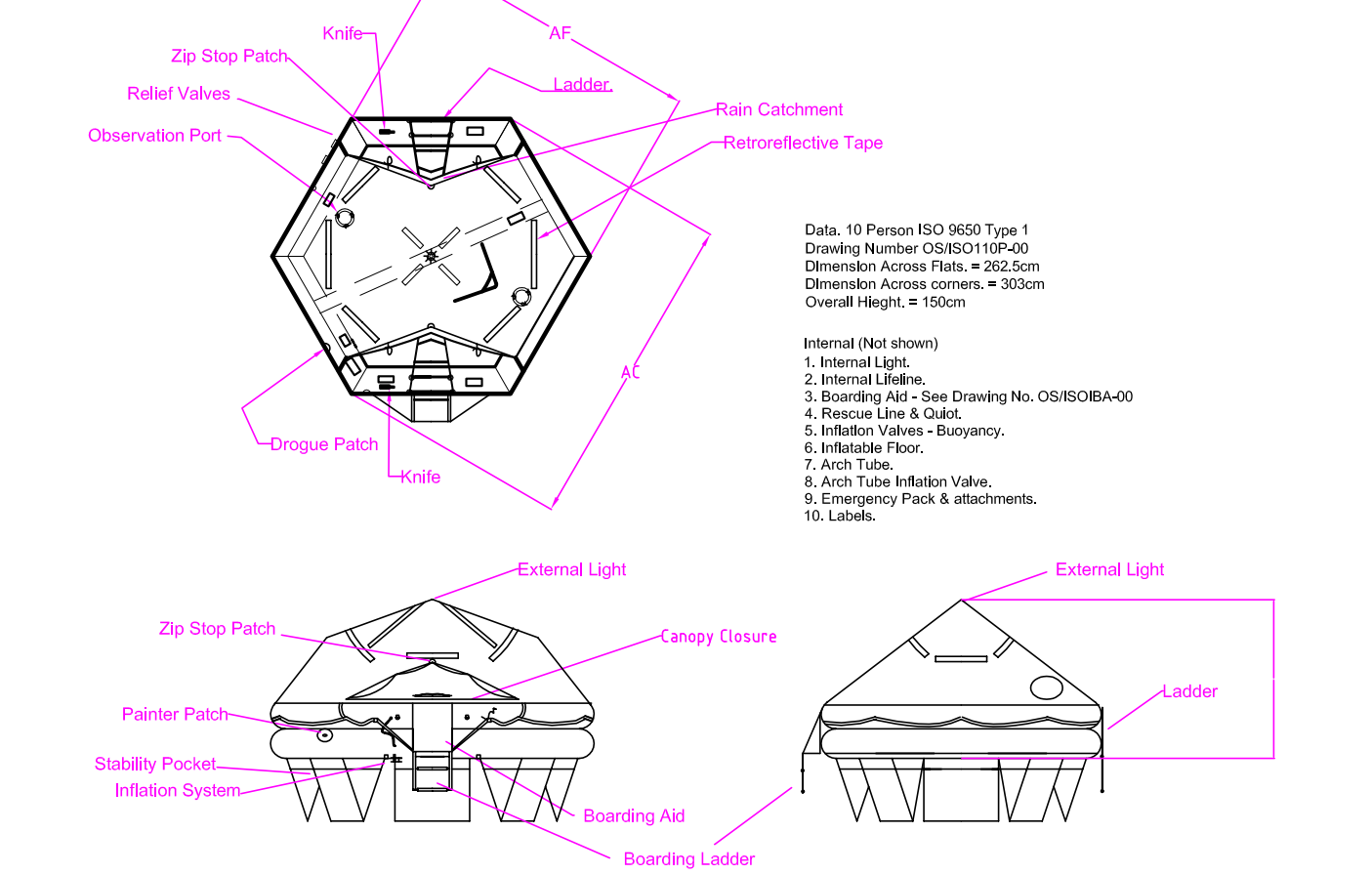

2.1.4 ~ 10 Person



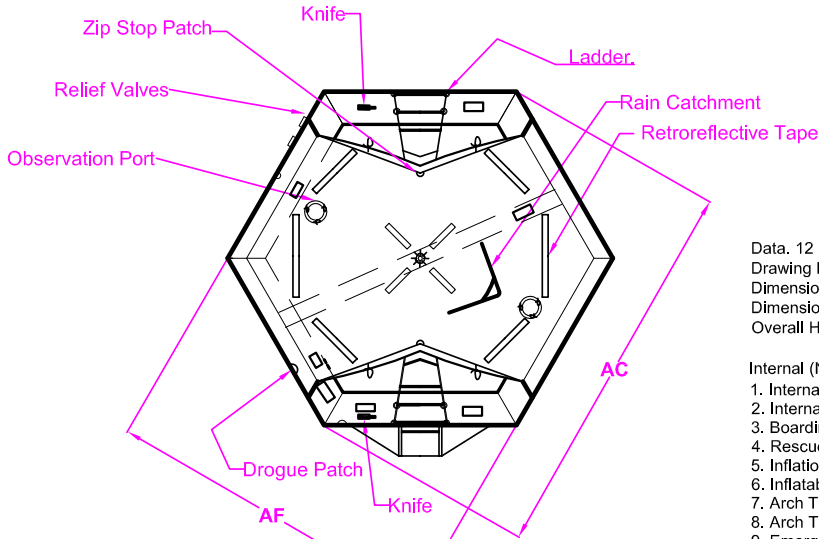

Section:	Liferaft Description Classification and Data			 OCEAN SAFETY®
DATE:	31/10/2020	CREATED BY:	P.Marlow	
ISSUE:	02/2020	CHECKED BY	J.Beaumont	

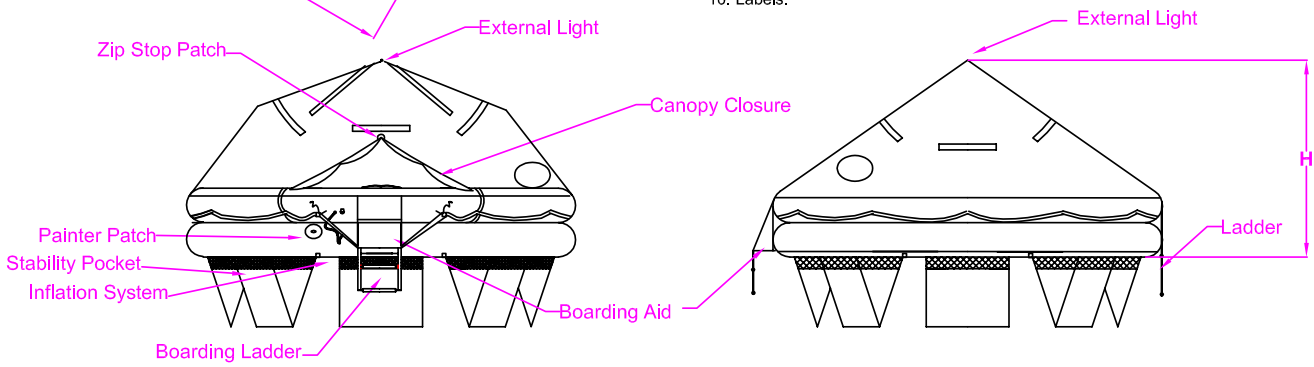

Data. 12 Person ISO 9650 Type 1
Drawing Number OS/ISO112P-00
Dimension Across Flats. = 285cm
Dimension Across corners. = 329cm
Overall Height. = 166cm

- Internal (Not shown)
1. Internal Light.
 2. Internal Lifeline.
 3. Boarding Aid - See Drawing No. OS/ISOIBA-00
 4. Rescue Line & Quiot.
 5. Inflation Valves - Buoyancy.
 6. Inflatable Floor.
 7. Arch Tube.
 8. Arch Tube Inflation Valve.
 9. Emergency Pack & attachments.
 10. Labels.



Section:	Liferaft Description Classification and Data			 OCEAN SAFETY®
DATE:	31/10/2020	CREATED BY:	P.Marlow	
ISSUE:	02/2020	CHECKED BY	J.Beaumont	

2.2 ~ Emergency Packs

2.2.1 ~ ISO Pack 2, less than 24 hour pack.

The table below details the equipment that makes up the Ocean ISO pack 2 <24 hour emergency pack. Not all the items are packed into the Equipment Bag.

Table 1:

Part N°	Description	4P	6P	8P	10P	12P
OSL0310	Equipment Bag	1	1	1	1	1
OSL0315	Portable Buoyant Bailer	1	1	1	1	1
SUR0090	Sponge	2	2	2	2	2
SUR0165	Whistle	1	1	1	1	1
OSL0275	Torch & Spares	2	2	2	2	2
SUR0030	Signal Mirror	1	1	1	1	1
SUR0180	Seasickness Bag	4	6	8	10	12
OSL0320	Air Flow Tool (airflow valve only, refer to Fig 1)	1	1	1	1	1
OSL0330	Clam Seal Leak Repair Unit	2	2	2	2	2
OSL0099	Pump (requires adaptor, Fig 1/2 refer)	1	1	1	1	1
OSL0345	A8 Pump Adaptor (Fig 1 refers)	1	1	1	1	1
OSL0340	Airflow Pump Adaptor (Fig 2 refers)	1	1	1	1	1
OSL0265	Paddles	1	1	1	1	1
SUR0005	Sea Sick Pills	60	60	60	60	120
FLR5505	Hand Flares Red	3	3	3	3	3
FLR5500	Parachute Red	2	2	2	2	2
SUR0075	Safety Knife	1	1	1	1	1
SUR0135	Quoit & Line	1	1	1	1	1

Fig. 1 & 2 reference is on next page.

Note:

As from September 2020, water will no longer be put in to the Ocean ISO liferaft, less than 24 hour emergency pack.

For all Ocean ISO Liferafts before this time should continue to have water supplied.

Section:	Liferaft Description Classification and Data			
DATE:	31/10/2020	CREATED BY:	P.Marlow	
ISSUE:	02/2020	CHECKED BY	J.Beaumont	

Pump Adaptors.

When ordering a pump as a spare part, the correct pump adaptor shall be identified from the information below. Once the correct adaptor is identified please order the correct adaptor along with the pump.

Fig 1 ~ A8 Inlet Valve

Depicted below is an A8 top up valve fitted to the Ocean ISO range (after November 2011). The pump adaptor required for this valve is part No OSL0345.

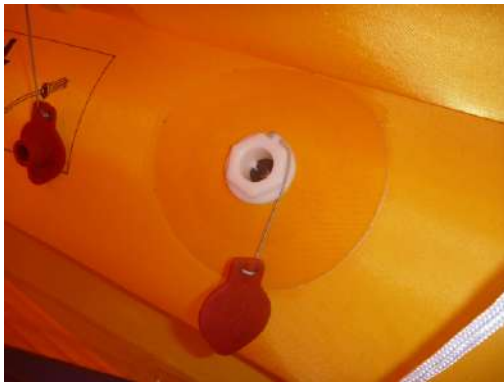



Fig 2 ~ Airflow Inlet Valve

Depicted below is an Airflow top up valve fitted to the Ocean ISO range pre November 2011 onwards. The pump adaptor required for this valve is part No OSL0340.



Section:	Liferaft Description Classification and Data			 OCEAN SAFETY®
DATE:	31/10/2020	CREATED BY:	P.Marlow	
ISSUE:	02/2020	CHECKED BY	J.Beaumont	

2.2.2 ~ ISO Pack 1, Greater than 24 hour pack.

The following items are required to conform to ISO pack 1 >24 hour pack.
1 >24 hour.

At time of purchase or at any service interval the emergency pack contained within the liferaft may be upgraded from a less than 24 hour pack (pack 2) to a greater than 24 hour pack (pack 1). The equipment required for the upgrade may be stowed in the liferaft or within a grab bag. Half a litre of water per person must be packed within the liferaft.

If a grab bag is used to raise the specification of the liferaft, the grab bag shall be made available at the time of service. Failure to present the grab bag will result in non conformance of the liferaft.

Table 2:

Part N°	Description	4P	6P	8P	10P	12P
OSL0310	Equipment Bag	1	1	1	1	1
OSL0315	Portable Buoyant Bailer	1	1	1	1	1
SUR0090	Sponge	2	2	2	2	2
SUR0165	Whistle	1	1	1	1	1
OSL0275	Torch & Spares	2	2	2	2	2
SUR0030	Signal Mirror	1	1	1	1	1
SUR0180	Seasickness Bag	4	6	8	10	12
OSL0320	Air Flow Tool (airflow valve only, refer to Fig 1)	1	1	1	1	1
OSL0330	Clam Seal Leak Repair Unit	2	2	2	2	2
OSL0099	Pump (requires adaptor, Fig 1/2 refer)	1	1	1	1	1
OSL0345	A8 Pump Adaptor (Fig 1 refers)	1	1	1	1	1
OSL0340	Airflow Pump Adaptor (Fig 2 refers)	1	1	1	1	1
OSL0265	Paddles	1	1	1	1	1
SUR0005	Sea Sick Pills	60	60	60	60	120
FLR5505	Hand Flares Red	6	6	6	6	6
FLR5500	Parachute Red	2	2	2	2	2
SUR0040	Drinking Water - 1.5 Lt Per Person	4	6	8	10	12
MED0115	First Aid Kit - IOS 9650	1	1	1	1	1
SUR0035	Food 10,000kJ	4	6	8	10	12
SUR0140	Thermal Protective Aid	2	2	2	2	2
SUR0075	Safety Knife	1	1	1	1	1
SUR0135	Quoit & Line	1	1	1	1	1
	<i>If grab bag required:</i>					
SUR0197	OS Yellow Grab Bag	1	1	1	1	1

Section:	Liferaft Description Classification and Data			 OCEAN SAFETY®
DATE:	31/10/2020	CREATED BY:	P.Marlow	
ISSUE:	02/2020	CHECKED BY	J.Beaumont	

2.2.3 ~ SOLAS B Pack

The table below details the pack content for the Ocean ISO Solas B pack.

At time of purchase or at any service interval the emergency pack contained within the liferaft may be upgraded from a less than 24 hour pack (pack 2) to a SOLAS B pack. The equipment required for the upgrade may be stowed in the liferaft or within a grab bag.

If a grab bag is used to raise the specification of the liferaft, the grab bag shall be made available at the time of service. Failure to present the grab bag will result in non conformance of the liferaft.

Table 3:

Part N°	Description	4P	6P	8P	10P	12P
OSL0310	Equipment Bag Containing	1	1	1	1	1
OSL0315	Portable Buoyant Bailer	1	1	1	1	1
SUR0090	Sponge	2	2	2	2	2
SUR0165	Whistle	1	1	1	1	1
OSL0275	Torch & Spares	2	2	2	2	2
SUR0030	Signal Mirror	1	1	1	1	1
SUR0180	Seasickness Bag	4	6	8	10	12
OSL0320	Air Flow Tool (airflow valve only, refer to Fig 1)	1	1	1	1	1
OSL0330	Clam Seal Leak Repair Unit	2	2	2	2	2
OSL0099	Pump (requires adaptor, Fig 1/2 refer)	1	1	1	1	1
OSL0345	A8 Pump Adaptor (Fig 1 refers)	1	1	1	1	1
OSL0340	Airflow Pump Adaptor (Fig 2 refers)	1	1	1	1	1
OSL0265	Paddles	1	1	1	1	1
SUR0005	Sea Sick Pills	60	60	60	60	120
FLR5505	Hand Flares Red	3	3	3	3	3
FLR5500	Parachute Red	2	2	2	2	2
MED0100	First Aid Kit - CAT C	1	1	1	1	1
FLR5010	Buoyant Smoke Signal	1	1	1	1	1
SUR0125	Spare Sea Anchor	1	1	1	1	1
SUR0115	Radar Reflector	1	1	1	1	1
SUR0160	Lifesaving Signal Card	1	1	1	1	1
SUR0140	Thermal Protective Aids	2	2	2	2	2
SUR0075	Safety Knife	1	1	1	1	1
SUR0135	Quoit & Line	1	1	1	1	1
	<i>If grab bag required</i>					
SUR0197	OS Yellow Grab Bag	1	1	1	1	1

Section:	Liferaft Description Classification and Data			 OCEAN SAFETY®
DATE:	31/10/2020	CREATED BY:	P.Marlow	
ISSUE:	02/2020	CHECKED BY	J.Beaumont	

2.2.5 ~ Ocean ISO UltraLite

Table 5 ISO Pack 2 <24 hour pack

The table below details the equipment that makes up the Ocean ISO UltraLite pack 2 <24 hour Pack. The pack detailed below meets the requirement of the standard ISO 9650 Part 1 pack 2 content, however it may not be upgraded to a Pack 1 (greater than 24 hour pack).

Part N°	Description	6P	8P	10P	12P
OSL0310	Equipment Bag	1	1	1	1
OSL0315	Portable Buoyant Bailer	1	1	1	1
SUR0090	Sponge	2	2	2	2
SUR0165	Whistle	1	1	1	1
OSL0275	Torch & Spares	1	1	1	1
SUR0030	Signal Mirror	1	1	1	1
SUR0180	Seasickness Bag	6	8	10	12
OSL0320	Air Flow Tool (airflow valve only, refer to Fig 1)	1	1	1	1
OSL0330	Clam Seal Leak Repair Unit	2	2	2	2
OSL0099	Pump (requires adaptor, Fig 1/2 refer)	1	1	1	1
OSL0345	A8 Pump Adaptor (Fig 1 refers)	1	1	1	1
OSL0340	Airflow Pump Adaptor (Fig 2 refers)	1	1	1	1
OSL0265	Paddles	1	1	1	1
SUR005	Sea Sick Pills	60	60	60	120
FLR5505	Hand Flares Red	3	3	3	3
FLR5500	Parachute Red	2	2	2	2
SUR0075	Safety Knife	1	1	1	1
SUR0135	Quoit & Line	1	1	1	1

Section:	Liferaft Description Classification and Data			 OCEAN SAFETY®
DATE:	31/10/2020	CREATED BY:	P.Marlow	
ISSUE:	02/2020	CHECKED BY	J.Beaumont	

2.3 ~ Cylinder & Inflation System

2.3.1 ~ Ocean ISO Cylinders

Pre 2013

Cylinder Data Ocean ISO

Test Pressure - 300 bar

Classification - EN 1964-1

Manufactures N° UCU001-200, UCV001-101

Certifying Body - TUV

Hydraulic Test Interval - 10 years

The Ocean Safety Ocean ISO range is supplied with fully certified cylinders. In the range there are 3 sizes of cylinder

Liferaft Capacity	Cylinder Capacity (L)	CO ₂ Charge (kg)	N ₂ Charge (kg)
4	2.5	1.475	0.094
6	5.0	2.2	0.094
8	5.0	3.0	0.12
10	7.5	3.43	0.14
12	7.5	4.68	0.19

Cylinder Data UltraLite

Test Pressure - 450 bar

Classification - ISO 12245 - Composite Cylinder

Certifying Body - TUV

Service Life - 15 years

Hydraulic Test Interval - 5 years

The Ocean Safety Ocean UltraLite range is supplied with fully certified cylinders. In the range there are 3 sizes of cylinder

Liferaft Capacity	Cylinder Capacity (L)	Gas Medium	Pressure (bar)
6	4.7	Air	240
8	4.7	Air	300
10	6.0	Air	300
12	6.8	Air	300

For cylinder charging instructions refer to the Leaflet Manual in appendix 1.

Warning - cylinder charging shall only be undertaken by Suitably qualified personnel.

Section:	Liferaft Description Classification and Data			 OCEAN SAFETY®
DATE:	31/10/2020	CREATED BY:	P.Marlow	
ISSUE:	02/2020	CHECKED BY	J.Beaumont	

2.3 Cylinder & Inflation System

2.3.2 Ocean ISO Cylinders

Post 2013 (*Changes indicated in Blue*)

Cylinder Data Ocean ISO

Test Pressure - 300 bar

Classification - EN 1964-1

Manufactures N° UCU001-200, UCV001-101

Certifying Body - TUV

Hydraulic Test Interval - 10 years

The Ocean Safety Ocean ISO range is supplied with fully certified cylinders. In the range there are 3 sizes of cylinder

Liferaft Capacity	Cylinder Capacity (L)	CO ₂ Charge (kg)	N ₂ Charge (kg)
4	2.5	1.475	0.094
6	5.0	3.0	0.12
8	5.0	3.0	0.12
10	7.5	4.68	0.19
12	7.5	4.68	0.19

Cylinder Data UltraLite

Test Pressure - 450 bar

Classification - ISO 12245 - Composite Cylinder

Certifying Body - TUV

Service Life - 15 years

Hydraulic Test Interval - 5 years

The Ocean Safety Ocean UltraLite range is supplied with fully certified cylinders. In the range there are 3 sizes of cylinder

Liferaft Capacity	Cylinder Capacity (L)	Gas Medium	Pressure (bar)
6	4.7	Air	240
8	4.7	Air	300
10	6.0	Air	300
12	6.8	Air	300

For cylinder charging instructions refer to the Leaflet Manual in appendix 1.

Warning - cylinder charging shall only be undertaken by Suitably qualified personnel.

Section:	Liferaft Description Classification and Data			 OCEAN SAFETY®
DATE:	31/10/2020	CREATED BY:	P.Marlow	
ISSUE:	02/2020	CHECKED BY	J.Beaumont	

2.3.3 - Ocean ISO Inflation System

The inflation system installed on the Ocean ISO Liferaft comprises of the following components:

Part	Part No	Description	4P	6P	8P	10P	12P
A6 PRV	OSL0150	Pressure Relief Valve 2.5 Psi, White body, liferafts Pre November 2010	2	2	0	0	0
A10 PRV	OSL0160	Pressure Relief Valve 2.5Psi, White Body Liferafts pre November 2010	0	0	2	2	2
B10 PRV	OSL0165	Pressure Relief Valve 2.5Psi, White Body Liferafts post November 2010	2	2	2	2	2
A6 Bung	OSL0170	A6 Pressure Relief Valve Bung Red. Pre November 2010	2	2	0	0	0
GIST Inlet Valve	OSL0125	GIST Inlet Valve Unplated 1.2mmJet	2	2	2	2	2
Cylinder Valve	OSL0110	Cylinder Valve Twin M16x1.5- 250bar -DIN 477 28.8 Thread C/W Syphon Tube, Torque Coupling and Break Stem Seal	1	1	1	1	1
Torque Drive Assembly	OSL0105	Torque Drive Assembly	1	1	1	1	1
GIST Operating head	OSL0100	Operating Head Torsional	1	1	1	1	1
High Pressure Hose	OSL0135	Hose Assembly 0.5m Long	2	2	2	2	2
Transfer Valve	OSL0190	Airflow Transfer Valve -0.5 Psi Pre June 2011 only	1	1	1	1	1
Transfer Valve	OSL0195	A8T Transfer Valve - 0.5 Psi- Post June 2011 only	1	1	1	1	1

For specific details regarding the inflation system, refer to the Leaflet manual, extract in Section 5.

Section:	Liferaft Description Classification and Data			 OCEAN SAFETY®
DATE:	31/10/2020	CREATED BY:	P.Marlow	
ISSUE:	02/2020	CHECKED BY	J.Beaumont	

2.3.4 ~ Ocean ISO Ultralite Inflation System

The inflation system installed on the UltraLite Liferaft comprises of,

Part	Part No	Description	6P	8P	10P	12P
A6 PRV	OSL0150	Pressure Relief Valve 2.5 Psi, White body, liferafts Pre November 2010	2	0	0	0
A10 PRV	OSL0160	Pressure Relief Valve 2.5Psi, White Body Liferafts pre November 2010	0	2	2	2
B10 PRV	OSL0165	Pressure Relief Valve 2.5Psi, White Body Liferafts post November 2010	2	2	2	2
A6 Bung	OSL0170	A6 Pressure Relief Valve Bung Red. Pre November 2010	2	0	0	0
GIST Inlet Valve	OSL0125	GIST Inlet Valve Unplated 1.2mmJet	2	2	2	2
Cylinder Valve	OSL0140	Cylinder Valve Single M18x1.5- 450bar - M18 Parallel Thread C/W O Ring Set, Cutter Assembly and Diaphragm	1	1	1	1
Twin Outlet Adaptor	OSL0143	GIS Port adaptor	1	1	1	1
GIS Operating head	OSL0100	Operating Head GIS System	1	1	1	1
High Pressure Hose	OSL0135	Hose Assembly 0.5m Long	2	2	2	2
Transfer Valve	OSL0190	Airflow Transfer Valve -0.5 Psi Pre June 2011 only	1	1	1	1
Transfer Valve	OSL0195	A8T Transfer Valve - 0.5 Psi- Post June 2011 only	1	1	1	1

For specific details regarding the inflation system, refer to the Leaflet manual, extract in Section 5

Section:	Liferaft Description Classification and Data			 OCEAN SAFETY®
DATE:	31/10/2020	CREATED BY:	P.Marlow	
ISSUE:	02/2020	CHECKED BY	J.Beaumont	

2.4 ~ Manufactures Recommended Service Intervals

The following service intervals are the manufactures recommended maximum service intervals for average use in average conditions. If the liferaft is exposed to extreme conditions it is recommended that the length of the service interval is reduced accordingly.

Where the liferaft is being used to conform to Flag Administration approved regulations, the service guide lines laid out by the Flag Administration shall be followed up to a maximum length of the interval stated buy the manufacturer.

With the changes to the Ocean ISO especially the vacuum bag the service intervals have been increased:

Service Intervals: Every 3 years up to 18 years then annually, Hydrostatic Cylinder Test to remain and conducted when necessary, likely to be 3rd service after 9 years.

	Service Interval 1	Service Interval 2	Service Interval 3	Service Interval 4	Service Interval 5	Service Interval 6	Service Interval 7	Service Interval 8 Onwards
Years of service after commissioning	Year 3	Year 6	Year 9	Year 12	Year 15	Year 18	Year 19	Year 20
Ocean ISO	3 years	3 years	3 years	3 years	3 years	3 years	Annual	Annual
Ocean ISO Ultralite	3 years	3 years	3 years	3 years	3 years	3 years	Annual	Annual

Our service interval remains 3 years but is restricted by the inclusion of a dated First Aid Kit. The First Aid kit or any other dated item does not change our recommended service interval.

Section:	Liferaft Description Classification and Data			 OCEAN SAFETY®
DATE:	31/10/2020	CREATED BY:	P.Marlow	
ISSUE:	02/2020	CHECKED BY	J.Beaumont	

2.5 ~ Containers & Valise Details

2.5.1 ~ Ocean ISO Mk1 Container - Pre 2020

Containers are manufactured from GRP or FRP and are supplied in two halves. The bottom section features drainage holes, grommet location hole and in the case of the FRP Ultralite container, guides to aid location in packing.

For the standard Ocean ISO container the two halves are sealed together using a rubber sealing strip and held in place by plastic strapping bands. Refer to the specific packing instructions for further details.

The UltraLite containers are butted up top and bottom with the guides aiding location. The halves are then held in place by plastic strapping. The join is then taped. Refer to the specific packing instructions for further details.

All containers are drop tested to 6m and temperature tested between -15°C to +65°C. Only Ocean Safety supplied spares may be used in the assembly of the liferaft.

There are 3 sizes of container for the Ocean ISO liferaft.

Table 6 ~ 4, 6 and 8 man Ocean ISO, Mk1 Containers

Container Size	Designation Pre 01.11.11	Designation post 01.11.11
Size 1	Pack 2 (<24 hour)	Obsolete
Size 2	Pack1 (>24 hour) & SOLAS B Pack	Pack 2 (<24 hour)
Size 3	N/A	Pack1 (>24 hour) & SOLAS B Pack

Table 7 ~ 10 and 12 Man Containers - Note that there is no size 3 container for the 10 and 12 man Container

Container Size	Designation
Size 1	Pack 2 (<24 hour)
Size 2	Pack1 (>24 hour) & SOLAS B Pack
Size 3	N/A

Table 8 ~ UltraLite Containers - FRP Containers (Carbon Fibre)

Container Size	Designation
Size 1 - 6,8 and 10 man Container	Pack 2 (<24 hour)
Size 2 - 12 man container	Pack 2 (<24 hour)

Note: When the current stocks of the above containers have been depleted, new style containers will need to be used.

Section:	Liferaft Description Classification and Data			 OCEAN SAFETY®
DATE:	31/10/2020	CREATED BY:	P.Marlow	
ISSUE:	02/2020	CHECKED BY	J.Beaumont	

2.5.2 ~ Ocean ISO Mk2 Containers - Post September 2020

In 2019 & 2020 the containers for the Ocean ISO were re-designed.

The Mk2 containers, benefit from a new aesthetic with a seamless finish which delivers an increased volume. The container features integrated handles and internal guides. The containers are manufactured from GRP or FRP and are supplied in two halves. The bottom section also includes drainage holes & grommet location hole.

All containers are drop tested to 6m and temperature tested between -15°C to +65°C. Only Ocean Safety supplied spares may be used in the assembly of the liferaft.

Ocean ISO Containers Mk2

Capacity & Pack	Container Size L x W x H (mm)
Ocean ISO 4P <24 Pack	710 x 490 x 240
Ocean ISO 4P >24 & SOLAS B pack	710 x 490 x 280
Ocean ISO 6P <24 Pack	710 x 490 x 280
Ocean ISO 6P >24 & SOLAS B Pack	800 x 520 x 310
Ocean ISO 8P <24 pack	800 x 520 x 280
Ocean ISO 8P & >24 & SOLAS B pack	800 x 520 x 310
Ocean ISO 10 <24 pack	890 x 520 x 280
Ocean ISO 10 >24 & SOLAS B pack	890 x 520 x 310
Ocean ISO 12 <24 pack	890 x 520 x 280
Ocean ISO 12P >24 & SOLAS B pack	890 x 520 x 310



Ocean ISO Ultralite Containers Mk2

Capacity & <24 hour Pack	Container Size L x W x H (mm)
Ocean ISO Ultralite 6P	TBC
Ocean ISO Ultralite 8P	TBC
Ocean ISO Ultralite 10P	TBC
Ocean ISO Ultralite 12P	TBC



The Ocean Iso Ultralite Containers will be in production from December 2020.

Section:	Liferaft Description Classification and Data			
DATE:	31/10/2020	CREATED BY:	P.Marlow	
ISSUE:	02/2020	CHECKED BY	J.Beaumont	

2.5.3 ~ Valise

The standard Ocean ISO Valises are manufactured from PVC coated nylon and are supplied in suitcase style. 3 sizes available 4, 6/8 & 10 Person.



The Ultralite valises are manufactured using a carbon laminate sail cloth and are also supplied in suitcase style. 2 sizes available 6/8 & 10/12 Person.



There is access to service data from an externally mounted window. The halves are sealed together using a zip which is held in the closed position using retaining thread.

The valises are drop tested to 6m and temperature tested between -15°C to +65°C. Only Ocean Safety supplied spares may be used in the assembly of the liferaft.

Note: The liferaft within a valise have been vacuum bagged, to the appropriate size to fit the valise. Depending on where the valise has been stored then the shape of the vacuumed liferaft may change. Environmental conditions may also contribute to the liferaft expanding with the valise.

Section:	Disassembly & Inspection			
DATE:	31/10/2020	CREATED BY:	P.Marlow	
ISSUE:	02/2020	CHECKED BY	J.Beaumont	

Section ~ 3

Disassembly & Inspection

Ocean ISO / Ocean ISO Ultralite Liferafts

Including the Mk2 Container

Section:	Disassembly & Inspection			 OCEAN SAFETY®
DATE:	31/10/2020	CREATED BY:	P.Marlow	
ISSUE:	02/2020	CHECKED BY	J.Beaumont	

Section 3 - Disassembly & Inspection

All modifications to the following sections shall be recorded in the table provided below. Once a new section is issued, replace the old version of the manual and destroy the obsolete pages.

Revision N°	Sections Affected	Issue Date	Inserted Date	Signature
Rev 0109	3.2 container	02.06.09		C.Perks
Rev 1010	3.1.1, 3.1.2 & 3.7	07.10.10		C. Perks
Rev 0612	Editorial changes only	27.06.12		J.Beaumont
02/2000	Complete update including the Mk2 container & the relevant enhancements	31/10/2020	31/10/2020	P.Marlow

Section:	Disassembly & Inspection			
DATE:	31/10/2020	CREATED BY:	P.Marlow	
ISSUE:	02/2020	CHECKED BY	J.Beaumont	

3 ~ Disassembly & Inspection

3.1 ~ Introduction

3.2 ~ Unpacking

3.2.1 ~ Valise

3.2.2 ~ Container

3.3 - Inflation Procedure

3.4 ~ Cleaning

3.4.1 ~ Container

3.4.2 ~ Valise

3.4.3 ~ Cylinder

3.4.4 ~ HP Hoses

3.4.5 ~ Inflation System

3.5 - Inspection of Liferaft

3.5.1 ~ Outside of Liferaft

3.5.2 ~ Inside the Liferaft

3.5.3 ~ Underside of Liferaft

3.6 - Inspection of Emergency Pack

3.7 - Inspection of Inflation System

3.7.1 ~ Cylinder Inspection

3.7.2 ~ Inspecting the Hoses

3.8 - Inspection of Container

3.9 - Inspection of Valise

Section:	Disassembly & Inspection			
DATE:	31/10/2020	CREATED BY:	P.Marlow	
ISSUE:	02/2020	CHECKED BY	J.Beaumont	

3.1 ~ Introduction

The following section is a descriptive guide to the unpacking and inspection of equipment required prior to the servicing of the Ocean ISO / Ocean ISO Ultralite Liferafts.

The section encompasses the unpacking of the liferaft from both valise and container format and the disassembly of the inflation system. Cleaning instructions for each part of the liferaft assembly are also detailed.

From October 2020 onwards the Ocean ISO has a new style container, with it we have changed the style of vacuum bag that we use.

To allow to use the different vacuum bag a number of minor changes need to be conducted during the service of the liferaft.

- The Firing Wire need to be changed in the Operating Head from the loop firing wire to the twin ball firing wire.
- When fitting the vacuum Bag the ball firing wire needs to be located in the purpose made sleeve within the vacuum bag.
- The vacuum bag firing wire clamp will need to be used to hold the firing wire in position & to allow the firing lines of the painter to be attached.
- Before that can happen the firing lines will need to be added to the painter.

With the introduction of the Mk2 Container there is no requirement for the rubber H Seal to be used between the two halves of the container. The new Mk2 container has guides fitted to the bottom half to allow the container to fit together better. Once the banding has been fitted, then adhesive tape is then used to seal the container.

Section:	Disassembly & Inspection			
DATE:	31/10/2020	CREATED BY:	P.Marlow	
ISSUE:	02/2020	CHECKED BY	J.Beaumont	

3.2 ~ Unpacking

3.2.1 ~ Valise

1) Position the valise so the cylinder is at the bottom of the pack.



Note the painter line exit point. This indicates the position of the cylinder within the packed liferaft.

2) To access the breakaway zips, lift the flap covering the zips.



3) There is a thread run around the eyelets and zippers. Cut the thread so the valise looks like the picture above. This is done so that the valise can be opened.

4) With the zips free to move, place the liferaft down on the floor and remove the top half of the valise to gain access to the Vacuum packed liferaft.



Section:	Disassembly & Inspection			
DATE:	31/10/2020	CREATED BY:	P.Marlow	
ISSUE:	02/2020	CHECKED BY	J.Beaumont	

Pre October 2020

5) Untie the painter or un-splice from the strong point on the vacuum bag.

Remove the tape and untie the loop realising the end of the painter line from the vacuum bag.



6) Carefully pull the side of the valise down so that the operating head can be accessed.



7) Remove the tape that is wrapped around the painter line so that the painter line can be manipulated.



8) With the painter line free to move thread the tail end back through the actuator cable.

Section:	Disassembly & Inspection			
DATE:	31/10/2020	CREATED BY:	P.Marlow	
ISSUE:	02/2020	CHECKED BY	J.Beaumont	



9) Carefully lift the painter line off of the actuator pin. If the painter line fails to move, stop. Investigate what is causing the increase in friction. Do not apply increase force to the painter line or actuator pin.

10) Untie the painter line pocket from the fixing point. The fixing point is a welded eyelet located on the opposite end of the vacuum bag to the operating head.

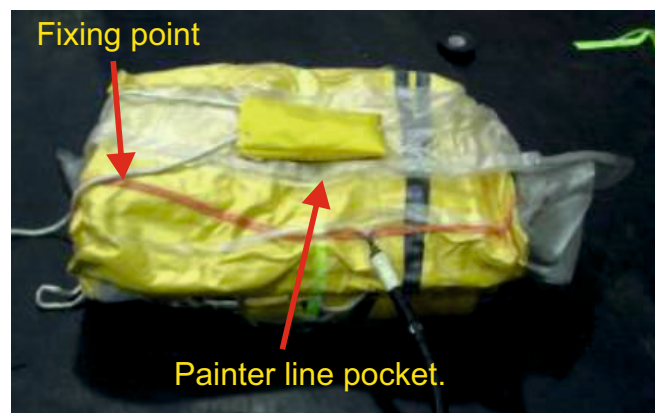

11) Lift the vacuum pack out of the valise. Cut the vacuum pack open along the straight welded edge of the vacuum bag.

Caution- Ensure that there is enough air inside the bag so that the PVC film can be pulled away from the fabric of the buoyancy tubes. To reduce the levels of vacuum in the bag, open the oral valve on the top of the bag.

Section:	Disassembly & Inspection			
DATE:	31/10/2020	CREATED BY:	P.Marlow	
ISSUE:	02/2020	CHECKED BY	J.Beaumont	

12a) Ocean ISO - Remove the tape and cable ties from around the operating head.



12b) UltraLite - Remove the retaining nut from the top of the operating head.

13) With the previous process complete slide the liferaft out of the vacuum bag and discard it (vacuum bags are single use only). Cut the retaining strip from around the liferaft and unfold it on the floor.



Section:	Disassembly & Inspection			
DATE:	31/10/2020	CREATED BY:	P.Marlow	
ISSUE:	02/2020	CHECKED BY	J.Beaumont	

14) With the liferaft unfolded, turn the bottom tube over so that the cylinder pocket is visible.

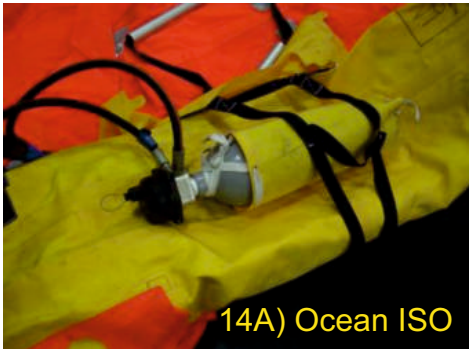

Note:
Mk2 are fitted with
ball type firing wire

15) Remove the operating head by loosening the retaining screw or bolts.

With the retainer loosened push the operating head up off of the top of the cylinder valve.



16) Using a 16mm spanner remove the high pressure hoses from the cylinder.

Caution - when working with and UltraLite, brace the twin outlet adaptor through out this process.



Warning - Remove one hose at a time. Once the hose is removed, a recoil cap shall be located into the empty slot and tightened.

17) How remove the cylinder from the pocket.

Section:	Disassembly & Inspection			
DATE:	31/10/2020	CREATED BY:	P.Marlow	
ISSUE:	02/2020	CHECKED BY	J.Beaumont	

Post October 2020

5) Untie the firing lines of the painter from the Vacuum Bag Painter Clamp.



6) Remove the vacuum Bag Firing Line Clamp.

Warning - Be careful not to pull the clamp while still attached to the Vacuum bag, as the raft is still armed at this point.

7) Open the valve of the vacuum bag to allow air to get inside the bag. this will allow you to spread the vacuum bag to make it easier to cut.

8) Cut the vacuum bag, so that the raft can be removed.



Caution - Ensure that there is enough air inside the bag so that the PVC film can be pulled away from the fabric of the buoyancy tubes. To reduce the levels of vacuum in the bag, open the oral valve on the top of the bag.

9) Slide the liferaft out of the vacuum bag and discard it (vacuum bags are single use only). Cut the retaining strip from around the liferaft and unfold it on the floor.

Section:	Disassembly & Inspection			
DATE:	31/10/2020	CREATED BY:	P.Marlow	
ISSUE:	02/2020	CHECKED BY	J.Beaumont	

3.2.2 ~ Container - Pre October 2020

1) Position the container so the cylinder is at the bottom of the pack.

Cut the retaining straps from around the container. For the UltraLite remove the adhesive tape around the periphery



Caution - Beware of airborne debris when cutting the strapping. Wear the required safety equipment.



2a) Ocean ISO -With the straps removed, use a boning tool to remove the top half of the container from the sealing strip.

2b) Ultralite, remove the adhesive tape, then carefully lift the top of the container off the packed liferaft.

3) Untie the painter from the strong point on the vacuum bag.

Remove the tape and untie the loop realising the end of the painter line from the vacuum bag.



4) Lift the vacuum packed liferaft from the container so that the operating head can be accessed.

Section:	Disassembly & Inspection			
DATE:	31/10/2020	CREATED BY:	P.Marlow	
ISSUE:	02/2020	CHECKED BY	J.Beaumont	



5) Remove the tape that is wrapped around the painter line so that the painter line can be manipulated.

6) With the painter line free to move thread the tail end back through the actuator cable.



7) Carefully lift the painter line off of the actuator pin. If the painter line fails to move, stop.

Investigate what is causing the increase in friction. Do not apply increase force to the painter line or actuator pin.

8) Untie the painter line pocket from the fixing point. The fixing point is a welded eyelet located on the opposite end of the vacuum bag to the operating head.

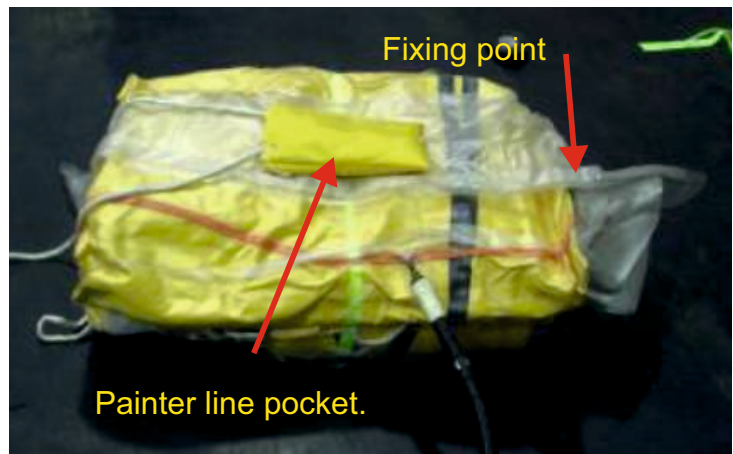

Section:	Disassembly & Inspection			
DATE:	31/10/2020	CREATED BY:	P.Marlow	
ISSUE:	02/2020	CHECKED BY	J.Beaumont	

9) Cut the vacuum pack open along the straight welded edge of the vacuum bag.

Caution- Ensure that there is enough air inside the bag so that the PVC film can be pulled away from the fabric of the buoyancy tubes. To reduce the levels of vacuum in the bag, open the oral valve on the top of the bag.



10a) Ocean ISO - Remove the tape and cable ties from around the operating head.

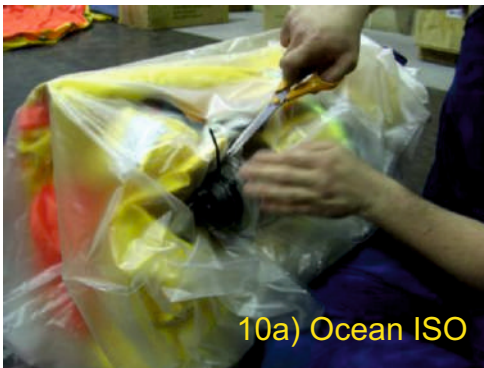

10b) UltraLite - Remove the retaining nut from the top of the operating head.



11) With the previous process complete slide the liferaft out of the vacuum bag and discard it (vacuum bags are single use only). Cut the retaining strip from around the liferaft and unfold it on the floor.

12) With the liferaft unfolded, turn the bottom tube over so that the cylinder pocket is visible.



Note:
For the Mk2, the firing wire would be the ball type.

Section:	Disassembly & Inspection			
DATE:	31/10/2020	CREATED BY:	P.Marlow	
ISSUE:	02/2020	CHECKED BY	J.Beaumont	

13) Remove the operating head by loosening the retaining screw or bolts.

With the retainer loosened push the operating head up off of the top of the cylinder valve.



14) Using a 16mm spanner remove the high pressure hoses from the cylinder.

Caution - when working with and UltraLite, brace the twin outlet adaptor through out this process.



Warning - Remove one hose at a time. Once the hose is removed, a recoil cap shall be located into the empty slot and tightened.

15) Remove the cylinder from the pocket.

Section:	Disassembly & Inspection			
DATE:	31/10/2020	CREATED BY:	P.Marlow	
ISSUE:	02/2020	CHECKED BY	J.Beaumont	

3.2.3 ~ Container - Post October 2020

Unpacking the Ocean ISO Mk2 liferafts is very similar to previous unpacking, but the vacuum bag, painter assembly to wiring wire are different.



1) Position the container with the label upwards. Giving yourself enough room to unpack & inflate the liferaft.

Cut the retaining straps from around the container & remove the adhesive tape which runs along the seam.

Caution ~ Beware of airborne debris when cutting the strapping. Wear the appropriate safety equipment.

2) Carefully remove the top half of the container which will expose the packed liferaft.

Untie the painter pocket from the vac bag.



3) Remove the tape from the firing lines. Untie the firing lines from the painter vacuum bag firing line clip, then remove the clip.

Warning - The inflation system remains in an armed state during this process. Ensure that no force is applied to the firing line throughout this operation. Note the system remains armed until the vacuum bag firing line clip has been removed.

Section:	Disassembly & Inspection			
DATE:	31/10/2020	CREATED BY:	P.Marlow	
ISSUE:	02/2020	CHECKED BY	J.Beaumont	

4) Cut the vacuum bag, so that the raft can be removed.

Caution- Ensure that there is enough air inside the bag so that the PVC film can be pulled away from the fabric of the buoyancy tubes. To reduce the levels of vacuum in the bag, open the oral valve on the top of the bag.



5) Slide the liferaft out of the vacuum bag and discard it (vacuum bags are single use only). Cut the retaining strip from around the liferaft and unfold it on the floor.

With the liferaft unfolded, turn the bottom tube over so that the cylinder pocket is visible.



6) Remove the operating head by loosening the retaining screw or bolts. With the retainer loosened push the operating head up off of the top of the cylinder valve.

7) Using a 16mm spanner remove the high pressure hoses from the cylinder.



Warning - Remove one hose at a time. Once the hose is removed, a recoil cap shall be located into the empty slot and tightened.

8) Remove the cylinder from the pocket.

Section:	Disassembly & Inspection			
DATE:	31/10/2020	CREATED BY:	P.Marlow	
ISSUE:	02/2020	CHECKED BY	J.Beaumont	

3.3 ~ Inflation Procedure

With the liferaft unpacked and laid out flat on the floor, locate the top up vales. Insert the inflation key into the bottom buoyancy tube and inflate until the PRV exhausts.

Repeat the process for the top tube. Ensure that the arch tube inflates before the PRV exhausts.

Deflate the top tube and inspect the arch tube to ensure that it holds pressure. Re-inflate the top buoyancy tube ready for test.

3.4 ~ Cleaning

Warning - do not use any solvent in the process of cleaning the liferaft.

Warning - Locate the PRV bung in the valve before cleaning the exterior of the liferaft.

To clean the liferaft use warm water with Ph neutral washing detergent.

Wash down using clean fresh water following the above process.

Dry off using lint free cloth or clean rag.

Leave to completely dry before re-packing.

Section:	Disassembly & Inspection			 OCEAN SAFETY®
DATE:	31/10/2020	CREATED BY:	P.Marlow	
ISSUE:	02/2020	CHECKED BY	J.Beaumont	

3.4.1 ~ Container

Wash the container clean using washing detergent. For stubborn or oily marks use solvent to clean the surface of the standard container. Note that solvents may not be used to clean the UltraLite containers.

Wash the container down with fresh clean water following the application of detergent or solvent.

All faces of the container shall be completely dry before the re-packing of the liferaft can commence.

3.4.2 ~ Valise

Warning - do not use any solvent in the process of cleaning the valise.

To clean the valise use warm water with Ph neutral washing detergent. wash down using clean fresh water following the above process.

Dry off using lint free cloth or rag.

Leave to completely dry before repacking.

3.4.3 ~ Cylinder

Wash the painted exterior wall of the cylinder clean using washing detergent. For stubborn or oily marks use solvent to clean the surface of the cylinder.

Wash down the cylinder with fresh clean water following the application of detergent or solvent.

Warning - The internal wall of the cylinder shall be dried using a heat generating appliance. The internal wall shall be completely dry before the cylinder is recharged.

3.4.4 ~ High Pressure Hoses

Use clean fresh water and cloth to clean the hoses outer casing. The connectors may be cleaned using mild abrasive pads the hoses shall be replaced if the marking on the connectors are not legible or the coating on the connectors is not intact.



Section:	Disassembly & Inspection			
DATE:	31/10/2020	CREATED BY:	P.Marlow	
ISSUE:	02/2020	CHECKED BY	J.Beaumont	

3.4.5 Inflation system

Top up valve.

Two fitted internally, one in each buoyancy tube (Fig.1), one fitted in the Arch (Fig.2)

Check that each of the valves operate correctly & that they have the safety caps attached.



B10 Relief valves.

Fitted on the exterior of the raft one for each buoyancy tube.

Check that each of the valves operate correctly & that they have the safety caps attached.

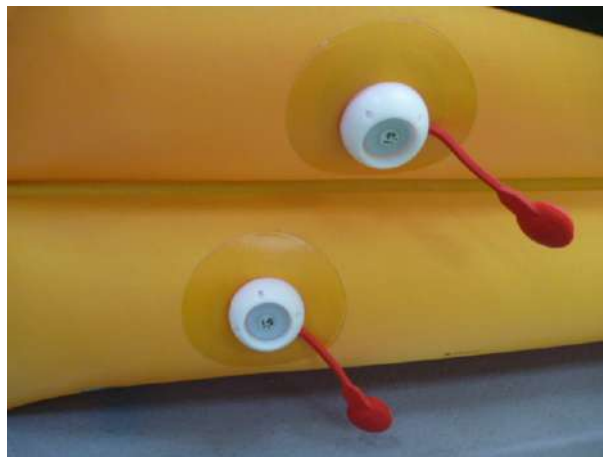

Please refer to the manufactures manual for details of maintenance, see section 5.

Section:	Disassembly & Inspection			
DATE:	31/10/2020	CREATED BY:	P.Marlow	
ISSUE:	02/2020	CHECKED BY	J.Beaumont	

3.5 ~ Inspection of Liferaft

The liferaft shall be checked for signs of damage, deterioration or for missing parts. There are three areas of the liferaft to visually inspect.

- The outside of the liferaft: the canopy, buoyancy tubes and all markings/attachements
- The inside of the liferaft: the canopy, buoyancy tubes, floor and all markings/attachements
- The underside of the liferaft: floor, markings and attachments

3.5.1 ~ Outside of Liferaft Fabric

Visually inspect the outside of the liferaft. check the fabric for signs of abrasion, staining, broken stitching or fraying. if any damage is found mark the effected area with a chinagraph pencil.

Visually inspect the markings and labels on the outside of the liferaft. check that all markings are clean clear and legible.

Check the operation of the zips, velcro and attachment patches. Ensure that parts are clean and are able to function. Check the quantity of retro tape on the canopy. on the upper side of the liferaft there should be a total of 1000mm².

The liferaft is of a bonded construction. the main join between the ends of the tubes is identified by the overlying tape located at the rear of the liferaft. Check the seam for visual signs of derogation.

Test all cordages and patches with a sharp pull in the right direction. All parts must remain intact as a result of the test.

Inspect the boarding arrangement. The ramp should feature three stiffening rods, a ladder and be attached to the buoyancy tubes at four points, two at the bottom and two at the top of the ramp. Check that all parts of the ramp are in good working order. Inspect the webbings and fabric for signs of abrasion, broken stitching or fraying. Ensure that the connection to the buoyancy chamber is made good with the end of the rap pointing slightly upwards.



Section:	Disassembly & Inspection			
DATE:	31/10/2020	CREATED BY:	P.Marlow	
ISSUE:	02/2020	CHECKED BY	J.Beaumont	

3.5.2 ~ Inside of Liferaft

Check all parts of the fabric as per the outside of the liferaft with the additions of:

Top up valves - Check that the valves are clean and are in working order. Take the cap off the valve and depress the centre of the valve. Check that the valve reseats and stops the escape of gas from the buoyancy tube. Replace the cap.

Check the condition of the rescue quoit and line. Give a sharp tug on the quoit to check the connection between it and the line. Ensure that the line is neatly stowed and will not tangle any other part of the liferaft.

Visually inspect the condition of the knife. Check the blade is good condition, sharp and free from corrosion. Check the condition and operation of the whistle. the whistle shall be stowed so it does not become entangled in any part of the liferafts equipment.

Inspect the condition of the drogue and line. When unpacking the drogue not how it is packed for reference when re-packing. check the condition of the line. Ensure that the line is spliced onto the drogue, not tied with a knot. The ends of the line should be taped. Check that all ends of the rope are securely taped.

Inspect the owners manual located in the clear pocket hanging from the arch tube. the pocket shall be inspected for signs of damage. Check that all information contained in the manual is legible.

Inspect the light and light patch. As part of the inflation the external and internal lights should have been operated. Check that both the internal light are operating correctly. In the activation of the light the activation pin will have been pulled from the battery housing. Relocate the pin in the raised black buttons and reset the system.

Visually inspect the condition of the floor. Check that there is no damage to the thermal floor and all stitching is intact.

3.5.3 ~ Underside of Liferaft

Visually inspect the underside of the liferaft. Check that there is the required number of water pockets for the size of liferaft. Inspect the water pockets and ensure that they are in good working condition.

Inspect the condition of the righting ladder. Test the ladder by giving the ladder a short tug. All parts are to remain intact as a result of the test.



Section:	Disassembly & Inspection			
DATE:	31/10/2020	CREATED BY:	P.Marlow	
ISSUE:	02/2020	CHECKED BY	J.Beaumont	

3.6 ~ Inspection of Emergency Pack

Inside the emergency pack there are dated and non dated items. All items shall be checked for the condition of each part. Where a part is date sensitive, regardless of exterior condition the product shall be replaced with approved spares supplied by Ocean Safety.

The table below details each part of the standard emergency pack and states where items are date sensitive. Note that additional equipment that does not make up part of the standard pack will require inspection to ascertain whether an expiry date applies.

Part N°	Description	Expiry	Checks
OSL0310	Equipment Bag Containing	N/A	Condition
OSL0315	Portable Buoyant Bailer	N/A	Condition
SUR0090	Sponge	N/A	Condition
SUR0165	Whistle	N/A	Condition & Operataion
OSL0275	Torch & Spares	3	Expiry date and condition
SUR0030	Signal Mirror	N/A	Condition & Operation
SUR0180	Seasickness Bag	N/A	Condition
OSL0320	Air Flow Tool	N/A	Condition & Operation
OSL0330	Clam Seal Leak Repair Unit	N/A	Condition & Operation
OSL0099	Pump	N/A	Condition & Operation
OSL0345	A8 Pump Adaptor	N/A	Condition & Operation
OSL0340	Airflow Pump Adaptor	N/A	Condition & Operation
OSL0265	Paddles	N/A	Condition
SUR0005	Sea Sick Pills	3	Expiry date and condition
FLR5505	Hand Flares Red	4	Expiry date and condition
FLR5500	Parachute Red	4	Expiry date and condition
SUR0075	Safety Knife	N/A	Condition
SUR0135	Quoit & Line	N/A	Condition

Note:

All time expired items should be disposed off by following the local Government guidelines. Where at all possible recycling schemes should be adhered too.

Section:	Disassembly & Inspection			
DATE:	31/10/2020	CREATED BY:	P.Marlow	
ISSUE:	02/2020	CHECKED BY	J.Beaumont	

3.7 ~ Inflation System

3.7.1 ~ Cylinder

Warning - only service operators correctly trained and certified by Ocean Safety or Leaffield Marine are permitted to undertake the service and inspection of cylinders and cylinder valves.

Fully charged cylinders shall only be discharged by operators correctly trained and certified by Ocean Safety or Leaffield Marine. The discharge of a cylinder shall be undertaken with the cylinder securely fastened inside a chain vice or similar device.

Any cylinder found to be damaged by impact or corrosion shall be returned to Ocean Safety or nearest agent for full hydraulic testing and possible refurbishment or disposal.

Note for Ultralite cylinders - A twin outlet adaptor is fitted to the outlet of the cylinder valve. The twin outlet adaptor is bonded in position using a thread locking compound. If the adaptor is loose it will require re-bonding at the point of service. Refer to remedial action and repairs for details.

3.7.2 ~ Inspecting the Hoses

Visually examine the outer surface of the hose & metal fittings.

Hoses should be replaced if signs of:

- If you see red corrosion
- If metal fittings are distorted
- Any signs of damage, cuts or abrasions.
- Any bulges or kinks.
- Replace the O-ring is damaged or distorted
-

Section:	Disassembly & Inspection			
DATE:	31/10/2020	CREATED BY:	P.Marlow	
ISSUE:	02/2020	CHECKED BY	J.Beaumont	

3.8 ~ Inspection of Container

3.8.1 ~ Outer Surface

Visually inspect the outer face of the container checking for cracks through the container or chips or cracks in the white gel coat layer. The container shall be replaced if there are cracks or holes right through the laminate. Chips in the gel coat may be repaired using a GRP repair kit.

3.8.2 ~ Carbon Containers

The containers are coated with a UV resistant lacquer. Any damage to this protective layer will render the container not serviceable for the pre defined service interval. In this instance the container is to be replaced.

The carbon container is fitted with guides on the lower container half. if there are less than four on the lower half of the container, refer to the repairs section for guidance.

3.8.3 ~ Inner Surface

Ensure that there are no sharp points that could damage the vacuum bag or the fabric of the liferaft. If any sharp points are found they may be rubbed flat using abrasive paper.

Caution - while sanding down GRP or FRP correct protective equipment must be worn to protect the operator from complications due to exposure to GRP or FRP dust.

Section:	Disassembly & Inspection			
DATE:	31/10/2020	CREATED BY:	P.Marlow	
ISSUE:	02/2020	CHECKED BY	J.Beaumont	

3.9 ~ Inspection Valise

Check the exterior of the valise. Ensure that all marking are clear and legible. Check the condition of the label pocket and content label pocket. Ensure that the pockets are not damaged and can safely contain the relevant labels as required.

Visually inspect the manually test the zips to ensure correct operation. Visually check the covering flap that locates over the zip is undamaged.

Visually check and manually test the webbing handles. All stitching and webbing should be intact without signs of damage or fatigue.

Section:	Testing			
DATE:	31/10/02020	CREATED BY:	P.Marlow	
ISSUE:	02/2020	CHECKED BY	J.Beaumont	

Section ~ 4

Testing

Ocean ISO / Ocean ISO Ultralite Liferrafts

Including the Mk2 Container

Section:	Testing			
DATE:	31/10/02020	CREATED BY:	P.Marlow	
ISSUE:	02/2020	CHECKED BY	J.Beaumont	

4 ~ Testing

4.1 ~ Tools required

4.2 ~ Conditions and corrections

4.2.1 ~ Atmospheric Corrections

4.2.2 ~ Temperature Correction

4.2.3 ~ Combined Correction

4.3 ~ Test procedure

4.4 ~ Pressure Relief Valve Reseat Pressure

4.5 ~ Air Holding Test

4.6 ~ Proof Pressure

4.7 ~ Cylinder Testing

4.7.1 ~ Ocean ISO Cylinders

4.7.2 ~ UltraLite Composite Cylinders

Section:	Testing			 OCEAN SAFETY®
DATE:	31/10/02020	CREATED BY:	P.Marlow	
ISSUE:	02/2020	CHECKED BY	J.Beaumont	

4.1 ~ Tools Required

Description	Part No	Qty
Transit plug - Gist	CYL2360	2
Torque Spanner/screwdriver 1.12Nm with 3mm allen key attachment	TOR001	1
Re set tool - GIST operating head	OSL9502	1
Cylinder valve recoil cap - GIST	OSL9503	4
Tool inlet valve assembly	OSL9510	1
Tool A10 Fitting Tool	OSL9512	1
Tool B10 Installation Spanner	OSL9514	1
Tool B10 Screw Bung	OSL9515	1
Tool A6 Spanner	OSL9517	1
A8 test adaptor	OSL9535	1
Manometer (0-400 mbar)	OSS5065	1
Additional Tools Required		
Description		Qty
Scales to weigh gas cylinders to an accuracy of +/- 1g		1
Screw driver set		1
Torque Spanner		1
Open ended torque spanner with 16mm spanner attachment		1
Fine screw driver or tool - removal of gaskets		1
Allen key 3mm - GIST operating head		1
China graph pencils		1
Fine point indelible pens		1
Socket - 36mm - A8 top up valve		1
Timing device		1
Thermometer		1
Clean and dry air supply - compressor		1
Vacuum Pump / Cleaner		1
Service manual		1

Section:	Testing			
DATE:	31/10/02020	CREATED BY:	P.Marlow	
ISSUE:	02/2020	CHECKED BY	J.Beaumont	

4.2 ~ Conditions and Corrections

All tests are to be carried out under stable conditions, as free as possible from draughts and direct sunlight. All repair patches are to be subject to a minimum of 72 hours cure time prior to inflation testing.

4.2.1 ~ Atmospheric Corrections

The ambient pressure shall be recorded at the beginning and end of each test. Where the conditions vary during the test the following allowances may be employed to determine the results of the test.

The corrections only apply to a maximum atmospheric pressure rise or fall of 3mb.

- For every 1mb rise in atmospheric pressure increase the final test pressure by 1mb
- For every 1mb fall in atmospheric pressure decrease the final test pressure by 1mb

4.2.3 ~ Temperature Corrections

The ambient temperature shall be recorded at the beginning and end of each test. Where the conditions vary during the test the following allowances may be employed to determine the results of the test. Temperature corrections may only be applied to ambient temperature fluctuations to a maximum rise or fall of 3°C.

- For every 1°C rise in temperature reduced the final test pressure by 4mb.
- For every 1°C fall in temperature increase the final test pressure by 4mb.

4.2.4 ~ Combined Corrections

If there is a combined temperature and atmospheric pressure change then add the two correction factors together.

- Increase in temperature by 2°C = -8mb
- Increase in atmospheric pressure by 2mb = +2mb
- Resultant correction factor = -8mb +2mb = -6mb

Section:	Testing			
DATE:	31/10/02020	CREATED BY:	P.Marlow	
ISSUE:	02/2020	CHECKED BY	J.Beaumont	

4.3 ~ Test Procedure

To conduct the required tests atmospheric conditions shall be recorded. Readings shall be taken as the test is started and on completion of the required test period.

In addition to the atmospheric test atmospheric conditions shall be recorded. Readings shall be taken as the test is started and on completion of the required test period.

In addition to the atmospheric conditions readings shall be taken of the internal pressure within the buoyancy tubes.

Readings/measurments to be recorded

- Ambient temperature at start of test in °C
- Ambient temperature at the completion of test in °C
- Ambient pressure at the stat of the test in mb
- Ambient pressure at the completion of test in mb
- Internal pressure of buoyancy tubes at start of test in mb
- Internal pressure of buoyancy tubes on completion of the test in mb

4.4 ~ Pressure Relief Valve Reseat Pressure

Inflate each buoyancy tube separately and record the reseat pressure of the relief valve. Refer to table 4.1 for designed reseat pressure for each liferaft in the Ocean Range. If the pressure taken from the buoyancy tube is less than the figure in table 4.1, the valve shall be replaced. Please refer to chapter 5 Remedial Action and Repairs.

Table 4.1 - Valve Pressures

Valve	Maximum Opening Pressure (mb)	Minimum Reseat Pressure (mb)
A6	213	147.5
A10	213	168
B10	213	168

Section:	Testing			
DATE:	31/10/02020	CREATED BY:	P.Marlow	
ISSUE:	02/2020	CHECKED BY	J.Beaumont	

4.5 ~ Air Holding Test

Inflate each chamber in turn until the PRV exhausts.

Allow the pressure to settle for 60 minutes and insert the PRV bungs. With the bungs in place the test may begin by taking a pressure reading from each buoyancy tube.

Allow each chamber to stand for 60 minutes and take a further reading from the buoyancy tubes.

Apply the necessary temperature and atmospheric corrections for the ambient conditions. The sum of the ambient corrections and the variation in the pressure must not exceed 5% of the original pressure.

4.6 ~ Proof Pressure

Locate the PRV bungs in the valves. Note that some bungs may require securing with tape to maintain an air tight seal throughout the test.

Inflate each chamber in turn to 345mb (5psi)

Allow the pressure to settle for 60 minutes and take a further reading. The allowable drop over the hour settling period is 100mb. If the pressure drops more than 100mb reset the pressure 345mb and do one final check for 30 minutes. If the pressure drops more than 100mb again the test is deemed a fail. If the pressure drop is less than 100mb proceed to the next phase of the test.

Allow the chamber to stand for 15 minutes and take a further reading. Subsequent to applying standard allowances for temperature and ambient pressure variations the maximum difference in the pressure must not exceed 15% of the original pressure.

Section:	Testing			
DATE:	31/10/02020	CREATED BY:	P.Marlow	
ISSUE:	02/2020	CHECKED BY	J.Beaumont	

4.7 ~ Cylinder Testing

4.7.1 ~ Ocean ISO Cylinders

The cylinder shall be inspected by a qualified engineer at each scheduled or unscheduled service.

Hydraulic pressure testing of the cylinder shall be undertaken at 10 year intervals. Cylinders are marked on the neck ring with the scheduled test date. This test shall be performed by a qualified appointed by a qualified engineer. If this is not possible then the cylinder shall be returned to Ocean Safety for testing.

During service the cylinder shall be check weighed on calibrated scales to 3 d.p. For the check weighing all components shall be removed from the cylinder valve with the exception of the break stem.

Weigh the cylinder and compare the figure measured against the gross weight marked on the cylinder label. The weight measured must be within +/-0.010kg of the weight recorded in the gross weight box. If the cylinder is within tolerance and the cylinder is within the hydraulic test period stamped on the cylinder it may be reassembled and installed on the liferaft. If the cylinder is out of tolerance it is either discharged and returned to Ocean Safety, or serviced and refilled by a service engineer.

4.7.2 ~ UltraLite Composite Cylinders

The cylinder shall be inspected by a qualified engineer appointed by Ocean Safety at each scheduled or unscheduled service.

Hydraulic pressure testing of the cylinder shall be undertaken at 5 year intervals. Cylinders are marked on the neck ring with the scheduled testing date. This test shall be performed by a qualified engineer appointed by Ocean Safety. If this is not possible then the cylinder shall be returned to Ocean Safety for testing.

Composite cylinders have a maximum service life of 15 years. Cylinders with 12 months of the maximum service life (marked on data label of cylinder wall) shall be discharged and disposed of in an environmentally safe manner.

During service the cylinder shall be check weighed on calibrated scales to 3 d.p. The cylinders shall be weighed fitted with the following components:

- Cylinder valve
- Burst disk
- Twin outlet adaptors
- Cutter assembly

Weigh the cylinder and compare the figure measured against the weight 2 marked on the cylinder label. The weight measured must be the same as the weight recorded in the weight 2 box. If the cylinder is within tolerance and the cylinder is within the hydraulic test period denoted on the cylinder it may be reassembled and installed on the liferaft. If the cylinder is out of tolerance it is either discharged and returned to Ocean Safety, or serviced and refilled by a service engineer.

Section:	Remedial Actions and Repairs			
DATE:	31/10/2020	CREATED BY:	P.Marlow	
ISSUE:	02/2020	CHECKED BY	J.Beaumont	

Section ~ 5

Remedial Action & Repairs

Ocean ISO / Ocean ISO Ultralite Liferrafts

Including the Mk2 Container

Section:	Remedial Actions and Repairs			
DATE:	31/10/2020	CREATED BY:	P.Marlow	
ISSUE:	02/2020	CHECKED BY	J.Beaumont	

5 ~ Remedial Actions and Repairs

5.1 ~ Introduction

5.2 ~ Adhesives

5.2.1 ~ Storage Instructions

5.2.2 ~ Mixing Instructions

5.2.3 ~ Application of Adhesive

5.3 ~ Fabric Repairs

5.4 ~ Cordage

5.5 ~ Replacement of Component Parts

5.5.1 ~ Pressure Relief Valve

5.5.2 ~ Inlet Valve

5.5.3 ~ GIST Cylinder Valve Installation

5.5.4 ~ GIST Operating Head, Resetting Procedure

5.5.5 ~ GIST Refurbishment of Cylinder Valve after Firing.

5.5.6 ~ GIST Cylinder Charging Procedure

5.5.7 ~ Top Up Valve

5.6 ~ Ocean ISO Ultralite Components

5.6.1 ~ Cylinder Assembly

5.6.2 ~ GIS Cylinder Valve Installation

5.6.3 ~ GIS Fitting Penetrator Assembly

5.6.4 ~ GIS Assembly of operating Head to Cylinder Valve

5.6.5 ~ GIS Resetting Operating Head after Firing

5.6.6 ~ GIS Refurbishment of Cylinder Valve after Firing

5.7 ~ Ancillary Equipment

5.7.1 ~ Drogue & Line

5.7.2 ~ Safety Knife / Whistle

5.7.3 ~ Quoit & Line

5.7.4 ~ ISO Mk2 & Ultralite Container

5.8 ~ Torque Settings

Section:	Remedial Actions and Repairs			
DATE:	31/10/2020	CREATED BY:	P.Marlow	
ISSUE:	02/2020	CHECKED BY	J.Beaumont	

5.1 Introduction

The following section defines the scope and procedures for repairs on the Ocean Safety Ocean ISO Liferaft. All replacement parts or adhesives used on the liferaft shall be Ocean Safety approved spares.

Any part of the liferaft or equipment that is found to be damaged or non functional during the process of inspection and testing requires remedial action to be taken. Any part of the liferaft or ancillary equipment that can not be repaired within the parameters of this manual or appropriate manufactures owner's manual must be replaced using Ocean Safety supplied spares.

5.2 ~ Adhesives

Repairs to the Fabric of the liferaft shall only be undertaken using adhesive supplied by Ocean Safety:- Bostik 2402, Bostic NE486, Bostic 1400 or Apollo A3480

Warning - Adhesives shall be used in accordance with the manufactures instructions and only used in areas of the liferaft permitted by this manual.

Warning - Only use adhesive in well ventilated areas. Use the appropriate personal safety equipment when working with adhesives.

5.2.1 ~ Storage instructions

Apollo adhesives and hardeners have a shelf life of 12 months from the date of manufacture. Adhesives and hardeners shall be stored in the container provided and shall be stored with the supplied lid securely located.

The adhesive and hardener shall be stored in a clean dry place out of direct sun light. The storage condition of the adhesive and hardener shall not exceed 25°C and not fall below 10°C. Any adhesive or hardener that is stored outside the prescribed parameters must be disposed of in accordance with local laws.

Before using a batch of adhesive, the condition of the solution shall be checked for:

- An increase in viscosity (usually caused by an incorrectly fitted lid)
- signs that the adhesive has separated leaving a way residue over the surface of the missus
- Cloudiness or crystallisation of the hardener

if any of the above are found on inspection of the adhesive or hardener, the affected part shall not be used for repairs. The adhesive and/or hardener shall be disposed of in accordance with local laws.

Section:	Remedial Actions and Repairs			
DATE:	31/10/2020	CREATED BY:	P.Marlow	
ISSUE:	02/2020	CHECKED BY	J.Beaumont	

5.2.2 ~ Mixing Instructions

Prior to any measuring out of required adhesive, the sediment at the bottom of the holding container shall be mixed back into the main body of the adhesive.

Measure out the desired quantity of adhesive. Measure out equivalent 4% mass of hardener and add it to the pot.

The mixing of the adhesive with the hardener shall be performed in lacquered, glass or polythene containers. Ensure that containers are clean and dry prior to mixing. With both parts in one pot, stir the mixture for a minimum of 5 minutes. When the mixed adhesive is not in use, cover the pot to maintain a good pot life. Pot life of mixed adhesive is dependant on conditions, pot life of up to one hour is achievable. Once the adhesive becomes stringy on application, replace the adhesive.

5.2.3 ~ Application of Adhesive

Prior to the application of adhesive on fabric, the fabric shall be cleaned and prepared. Great care is required to ensure that the fabric is clean of debris and grease. Bonding interfaces shall be cleaned with toluene to ensure the fabric is clean. All surfaces must be completely dry with all solvent evaporated before adhesive may be applied.

Adhesive shall be applied using a brush with a wooden handle and natural fibre brushes. To apply the adhesive use a clean brush with a width of 25mm and a bristle length of 30mm. for woven fabrics three layers of adhesive are required. The first two layers are to be worked into the weave of the textile. The third should be used to finish with a smooth layer. Sufficient time shall be given between layers to allow the adhesive to become touch dry on the first two layers. This time will change with ambient conditions. on the third coat the two parts being bonded shall be brought together whilst the adhesive is tacky to the touch.

Warning - When applying and checking adhesive do not use finger tips. This will contaminate the adhesive. Use the back of a finger to touch the fabric. Keep contact to a minimum.

When bringing the two surfaces together the two parts must be lined up before contact is made. Once the pieces come together they may not be repositioned. if parts are not aligned correctly they must be pulled apart and the process repeated.

Once parts are correctly positioned, the bond shall be consolidated using a spatula or heavy roller. Work from the inside out and remove any air bubbles created when bringing the two layers together.

Section:	Remedial Actions and Repairs			
DATE:	31/10/2020	CREATED BY:	P.Marlow	
ISSUE:	02/2020	CHECKED BY	J.Beaumont	

5.3 ~ Fabric Repairs

An approved service station is required to hold stock of suitable coated fabric for repair patches. Any repair patch shall be cut from a fabric the same colour as the area being repaired. Fabric can be supplied as a service spare from Ocean Safety.

For the application of adhesive to patch and liferaft refer to section 5.2.3. All patches shall be checked for air holding capability following the required cure period of 72 hours. Any patches that are found to be leaking shall be reworked.

Use a circular patch to repair pin holes - minimum diameter 50mm

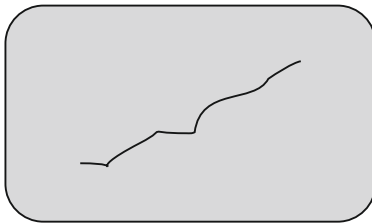
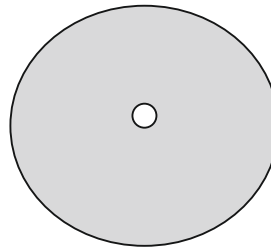

Use a rectangular patch to repair tears. The patch shall be a minimum of 25mm in width from the outside edge of the tear.

Use an L shaped patch may be used to cover striking tears. The patch shall be a minimum of 25mm in width from the outside edge of the tear.

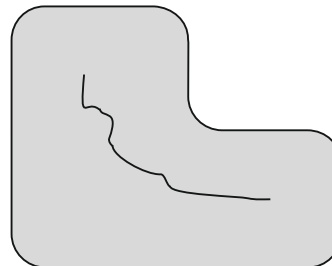

5.4 ~ Cordage

Any repairs to the cordage of the liferaft must be performed using a sewing machine. Repair by hand sewing is not permitted.

All liferafts repaired using a sewing machine shall be pressure tested in accordance with the airholding test procedure

Section:	Remedial Actions and Repairs			
DATE:	31/10/2020	CREATED BY:	P.Marlow	
ISSUE:	02/2020	CHECKED BY	J.Beaumont	

5.5 ~ Replacement of Component Parts

5.5.1 ~ Pressure Relief Valves

Due to the design of the PRV's, most leaks are evident from the centre of the valve. This makes an assessment of the root cause difficult. Both a loose valve and an issue with the sealing faces would result with a leak through the centre of the valve.

Firstly check the torque setting for the valve - Note this check shall be performed before any water or other lubricants are used. Using a torque wrench and the B10 tool, confirm the torque is set to **29Nm**.

If the torque is correctly set and the issue remains, inspect the sealing faces. Remove any debris with water.

If damage is located on the sealing faces, or the cleaning of the valve does not resolve the issue, the valve will require replacement.

The pressure relief valve is made up of two parts that are located internally and externally of the buoyancy tube. The valve can be removed by unscrewing the outer section of the valve using either the service spanner.

To replace a pressure relief valve both parts of the valve are to be removed. To retrieve the bottom half of the valve the old patch must be cut to gain access to the internal parts. A replacement valve shall be installed on a replacement patch to the correct torque ready for attachment the buoyancy tube. For torque setting, please refer to appendix 2.

The doubler patch is to be bonded into the required position following the procedure detailed in section 5.2.3. A doubler patch shall be consolidated correctly using a boning tool or roller. All patches must be checked for air holding capability following a minimum cure period of 72 hours. Any patches that fail the air holding test shall be reworked.

Section:	Remedial Actions and Repairs			 OCEAN SAFETY®
DATE:	31/10/2020	CREATED BY:	P.Marlow	
ISSUE:	02/2020	CHECKED BY	J.Beaumont	

5.5.2 ~ Inlet Valves

Extract from manufacture's manual M-07-IS-GIVT

- Gas Inflation System (Torsional) Inlet Valve Installation Instructions

Gas Inflation System (Torsional) Inlet Valve Installation Instructions

M-07-IS-GIVT
09/04/2014
Revision 8

1. Part List

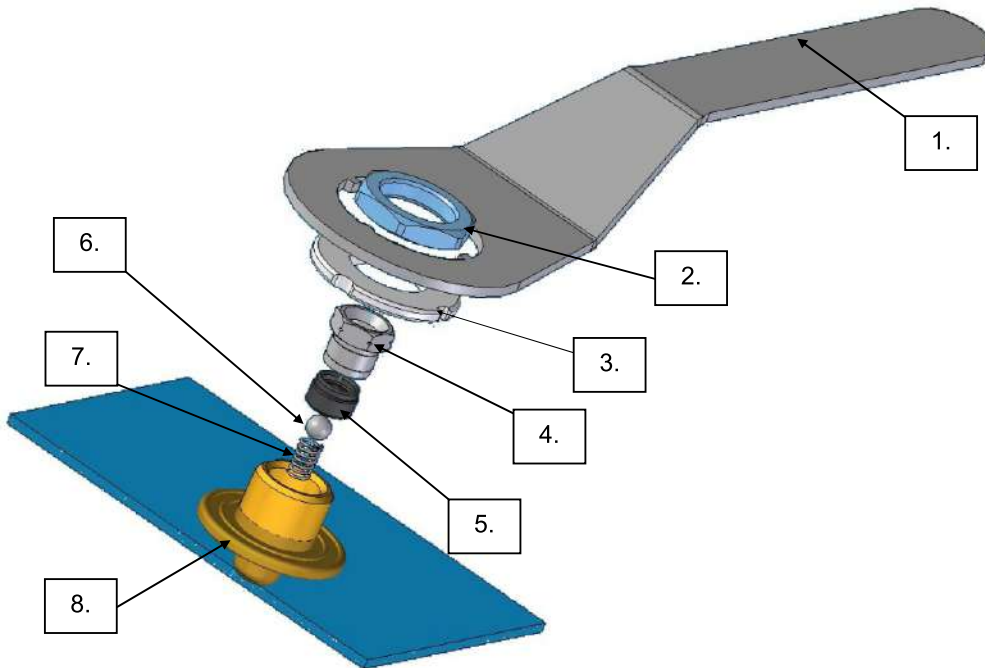

Item No:	Part No:	Description
1	0320000	Spanner
2	B15671 B15420	M24 Nut M24 Nut (Unplated)
3	17675	Plastic Washer
4	32400010 0806001	M16 Quick-Fit Connector Body M16 Quick-Fit Connector Body (Stainless Steel, Purple code)
5	18271	Ball Seat
6	03800016	Sealing Ball
7	19236	Spring
8	Various	Valve Body

Section:	Remedial Actions and Repairs			 OCEAN SAFETY®
DATE:	31/10/2020	CREATED BY:	P.Marlow	
ISSUE:	02/2020	CHECKED BY	J.Beaumont	

M-07-IS-GIVT Revision 8

Gas Inflation System (Torsional) Inlet Valve Installation Instructions

2. Installation

Tools required for this operation:

- 1 x GIST inlet valve spanner
- 1 x 33mm A/F Spanner

1. Cut a 24.5 / 24.0 mm diameter hole in the fabric. Push the M24 threaded section of the inlet valve body through the hole in the tube fabric.

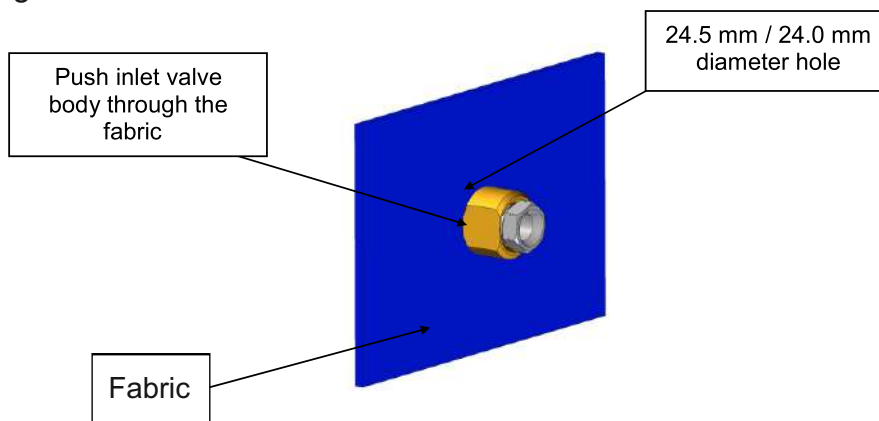

2. Place the washer over the M24 x 1.5 thread, ensuring that the flats line up.

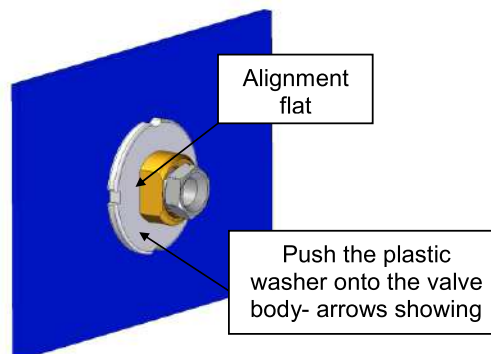

3. Locate the nut onto the inlet valve body and spin down the thread. Tighten hand tight.

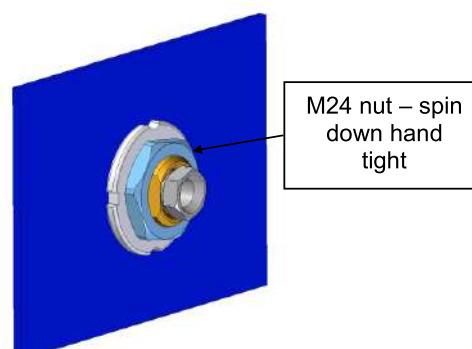

Section:	Remedial Actions and Repairs			 OCEAN SAFETY®
DATE:	31/10/2020	CREATED BY:	P.Marlow	
ISSUE:	02/2020	CHECKED BY	J.Beaumont	

M-07-IS-GIVT Revision 8

4. Locate the inlet valve spanner into the 4 locations on the outside diameter of the Washer. Align the jets in the inlet valve by ensuring the arrows on the spanner are orientated along the longitudinal axis of the tube.

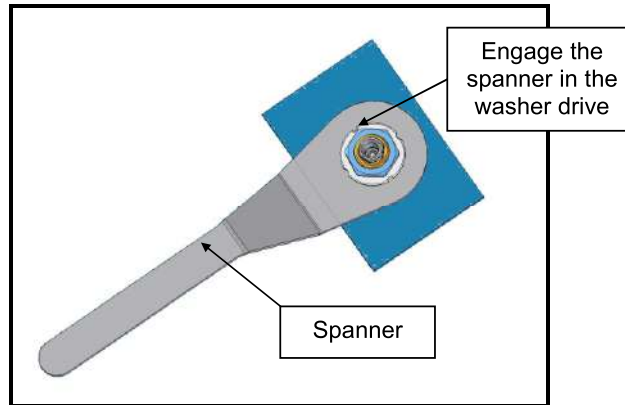

5. Locate a 33mm A/F socket and torque wrench on the M24 nut. Tighten the M24 nut to a torque of 30Nm (22.1 ft/lbs).

6. Remove the red plastic dust cap from the top thread of the inlet valve. The valve is now ready to accept the quick fit connector on the end of the high pressure hose. Push the connector firmly into the hole, make sure a click is heard and then rotate through 90 degrees. Check that the connection has been correctly made by pulling the hose connector firmly upwards, away from the valve.

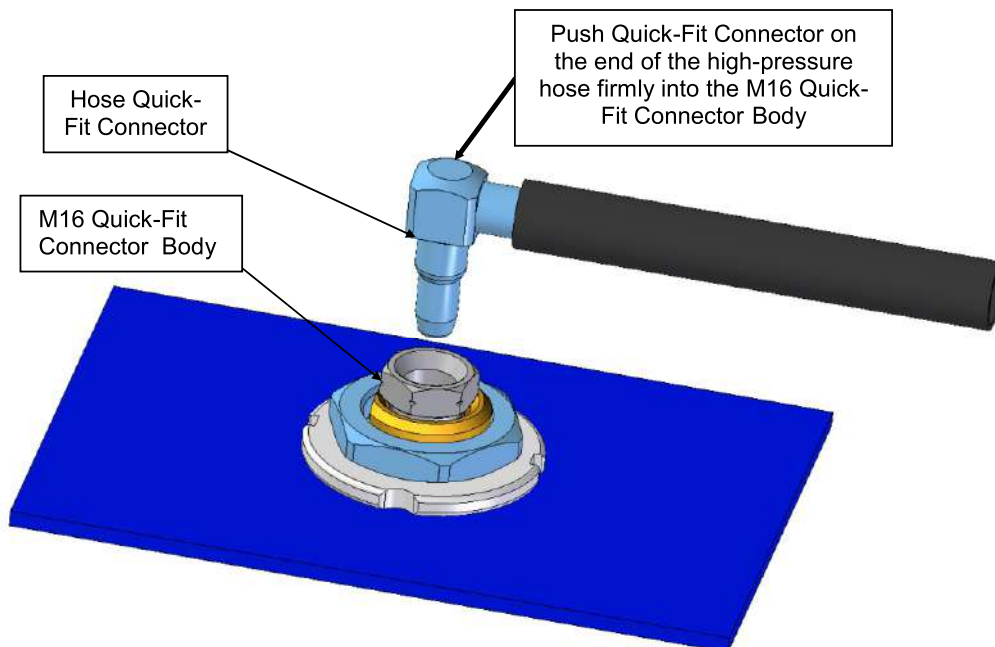

7. If the hose has not been correctly snapped into place it may blow out during inflation. In this case check that the 'O' Ring is still in place in the M16 Quick-Fit Connector Body before pushing together as described. If it is not present replace the M16 Quick-Fit Connector Body.

Section:	Remedial Actions and Repairs			
DATE:	31/10/2020	CREATED BY:	P.Marlow	
ISSUE:	02/2020	CHECKED BY	J.Beaumont	

M-07-IS-GIVT Revision 8

3. Service Instructions

3.1 If the valve is leaking from around the M16 Quick-Fit Connector Body or if the hose needs replacing:

Tools required for this operation:

- 1 x 16mm A/F spanner
- 1 x GIST inlet valve spanner
- Mild detergent
- Warm water

1. Engage the inlet valve spanner into the 4 locations on the outside diameter of the washer. Locate a 16mm A/F spanner onto the M16 Connector and unscrew. The Connector will remain connected to the end of the hose and is re-usable, if deemed to be in an acceptable condition.

2. Remove the rubber ball seal. Care must be taken when removing this as beneath the seal is a spring supporting the sealing ball. This ball may be ejected from the assembly resulting in loss or injury.

3. Remove the spring and the sealing ball and thoroughly clean the parts with a mild detergent and clean water. If the sealing ball, rubber seal or spring appear to be damaged or badly pitted, the parts should be replaced.

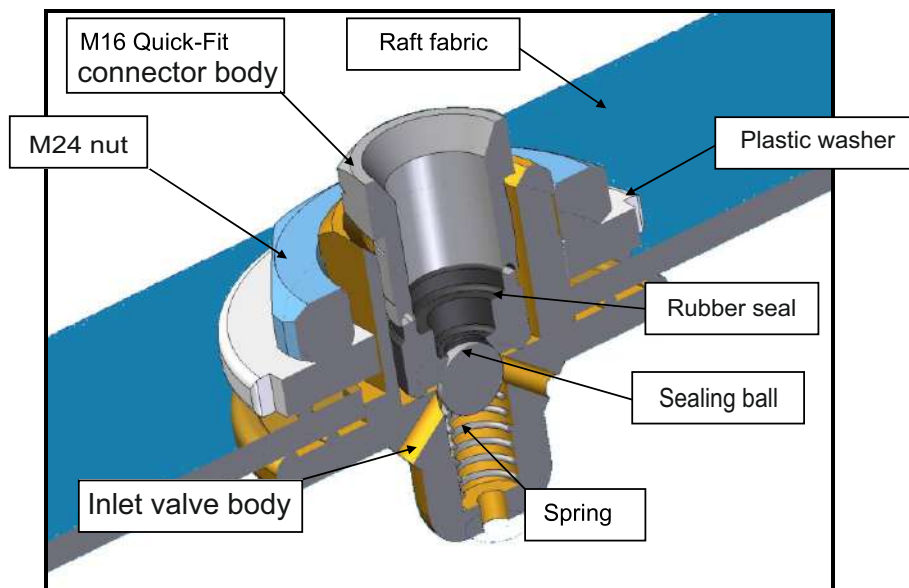

Section:	Remedial Actions and Repairs			 OCEAN SAFETY®
DATE:	31/10/2020	CREATED BY:	P.Marlow	
ISSUE:	02/2020	CHECKED BY	J.Beaumont	

M-07-IS-GIVT Revision 8

4. Thoroughly dry the components and lightly grease with Molykote 111.
5. Carefully put the spring in the valve body. Drop the sealing ball on top followed by the rubber seal. Important: Ensure that the seal is the right way up, tapered hole over the sealing ball, and push down square with the valve body.
6. Screw in the M16 Quick-Fit Connector Body and torque to a setting of 20Nm (15 ft/lb).
7. Operate the valve by pushing the 4mm rod, TM2238, through M16 Quick-Fit Connector Body and check that the metal ball moves freely against spring pressure.
8. Once the M16 Quick-Fit Connector Body and the Hose have been connected, the M16 Quick-Fit Connector Body becomes a permanent hose attachment.

3.2 If the valve is leaking from around the plastic washer and fabric:

This type of leakage occurs if the valve has become loose in the fabric. To identify this type of leak cover the area around the washer with soapy water and watch for bubbles. To rectify this type of leak, carry out the following procedure.

1. Locate the inlet valve spanner into the 4 locations on the outside diameter of the washer.
2. Locate a 33mm A/F spanner and torque wrench on the M24 nut. Rotate the spanner to align the jets in the inlet valve by ensuring the arrows on the spanner are orientated along the longitudinal axis of the tube. Tighten the M24 nut to torque 30Nm (22.1 ft/lbs).
3. Inflate the tube and check that the leak has stopped by applying some soapy water around the washer. If the valve is still leaking, bubbles will be visible and the washer should be replaced.

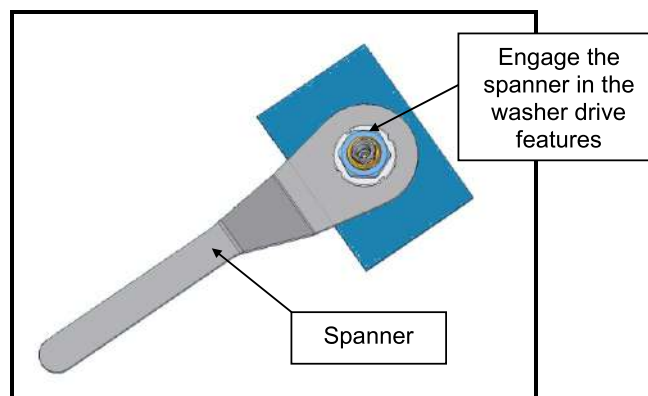

Section:	Remedial Actions and Repairs			
DATE:	31/10/2020	CREATED BY:	P.Marlow	
ISSUE:	02/2020	CHECKED BY	J.Beaumont	

M-07-UM-GIST Revision 14 ~ Section 5

5.5.3 ~ GIST Cylinder Valve Installation Extract from manufacture's manual

Warning: The following checks must be carried out prior to installation of cylinder valve to cylinder.

1. Ensure that the cylinder and Cylinder Valve threads are compatible and that the cylinder conforms to the standard specified for the working pressure on the Cylinder Valve. Ensure that the cylinder is approved for use in the applicable market.

2. Ensure that the Cylinder threads and interior are clean dry and free from unacceptable corrosion i.e. flaking or pitting.

3. Ensure that the Cylinder Valve threads show no visible sign of damage.

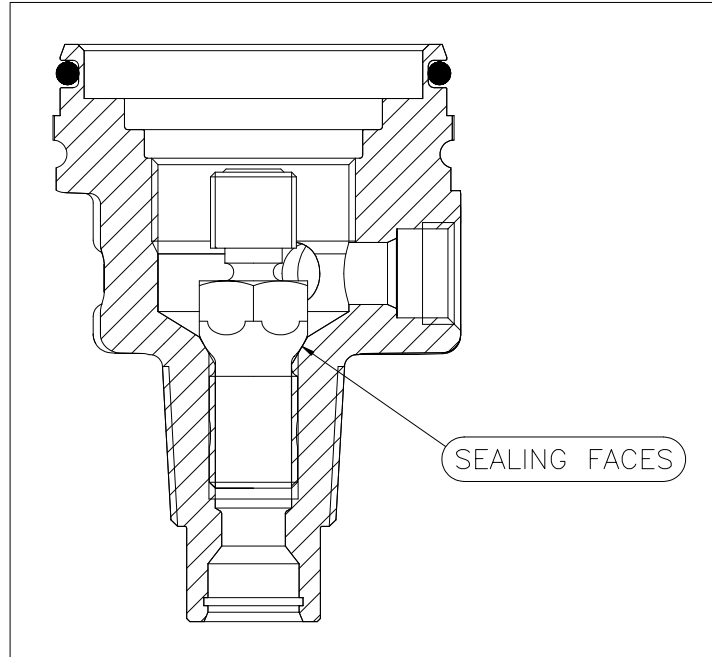

4. Ensure that the Syphon Tube (where fitted) is free to swivel and rotate.

5. Ensure that all Cylinder Valve Bores, recesses and sealing faces are clean and dry. Note that the Break Stem Seal Assembly may already be fitted to previously unused Cylinder Valves. If so, do not remove prior to filling.

6. Sealing material (PTFE Tape) should be applied to the threads as recommended by the Liferaft manufacturer or Leaffield Marine Ltd. No grease or oil should be used on the Cylinder Valve thread when fitting the Valve.

7. Tighten Cylinder Valve to a torque of 160-170Nm

Caution: If the valve is over tightened, the cylinder thread is incompatible or lubrication is applied to the thread, the valve body can distort & prevent the break stem sealing. This will often be indicated by the thread squeaking as the break stem is tightened.

Caution: Never insert any implement into the cylinder valve body that could damage the sealing face or break stem seal assembly.

Warning: Ensure the valve & cylinder is clean & dry before assembly.

Section:	Remedial Actions and Repairs			 OCEAN SAFETY®
DATE:	31/10/2020	CREATED BY:	P.Marlow	
ISSUE:	02/2020	CHECKED BY	J.Beaumont	

M-07-UM-GIST Revision 14 ~ Section 10

5.5.4 ~ GIST Operating Head, Resetting Procedure.

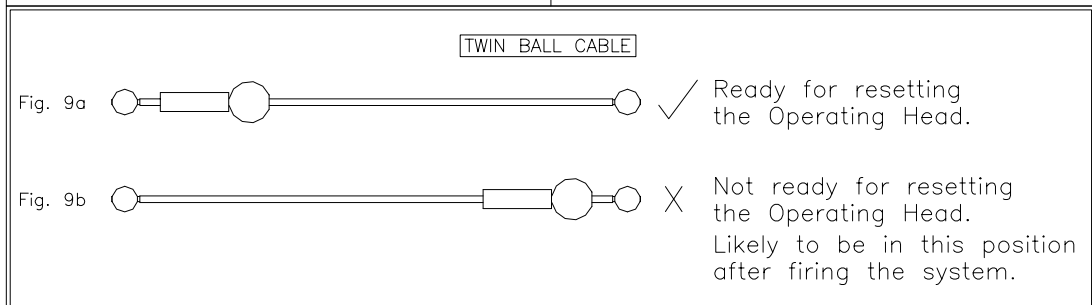
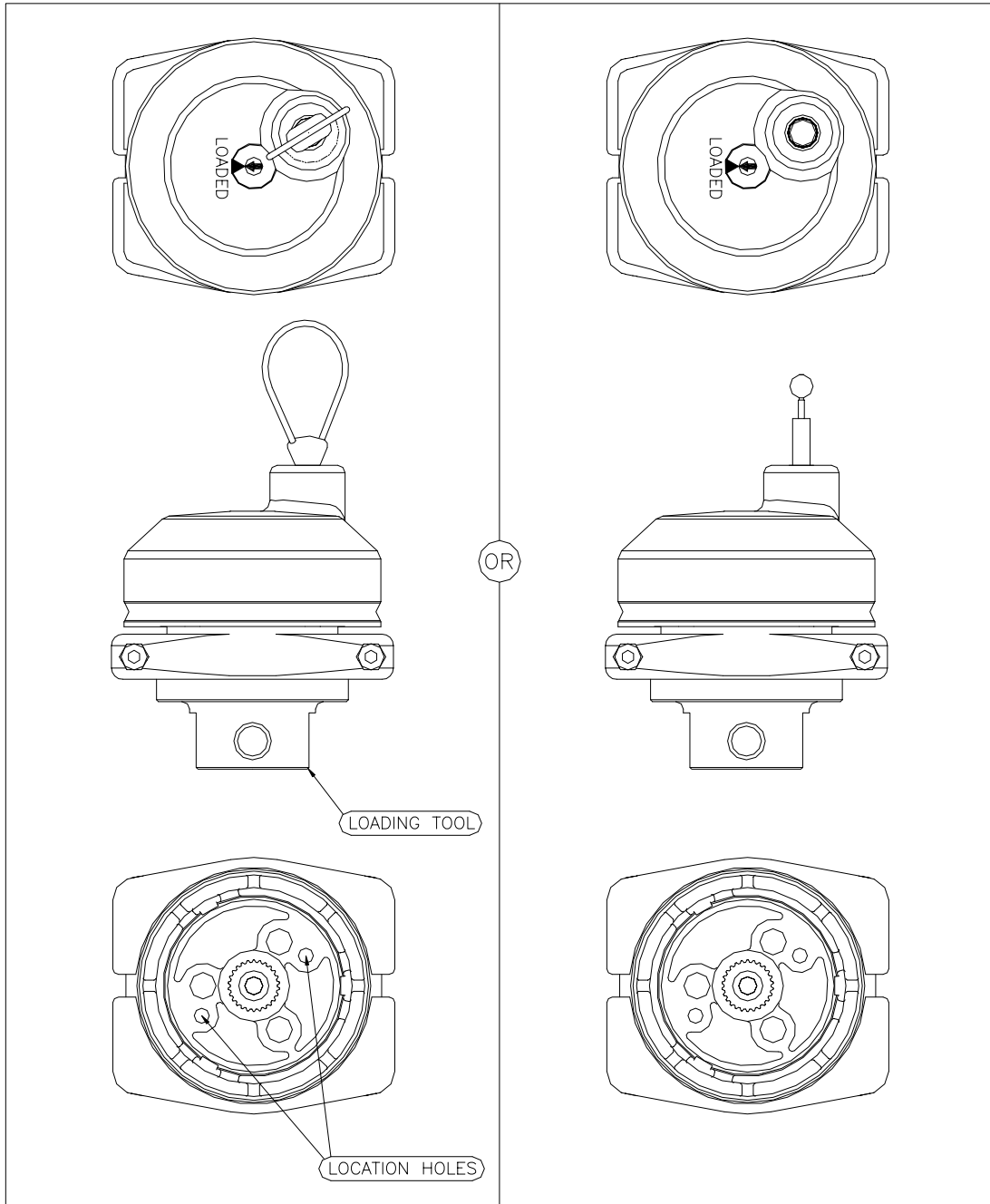

Section:	Remedial Actions and Repairs			
DATE:	31/10/2020	CREATED BY:	P.Marlow	
ISSUE:	02/2020	CHECKED BY	J.Beaumont	

M-07-UM-GIST Revision 14 ~ Section 10

GIST Operating Head, Resetting Procedure.

1. Remove the clamp screws retaining the operating head to the cylinder valve.
2. Remove the operating head from the cylinder valve.
3. Examine the operating head. Discard if damaged or more than 15 years old. Discard if the operating head is black and the cylinder is to be re-filled.
4. An operating head previously used in a deployment in water **MUST** be flushed through with clean water and dried thoroughly in air.

Warning: The operating head is intended as a sealed for life unit and must not be disassembled. It must not be cleaned with solvents, soaps or chemical agents. These may degrade the system components and cause a malfunction.

5. Check the firing wire assembly for the condition of sealing ball. Discard if damaged.

The white operating head must be fitted with a twin ball firing wire with a black seal.

Warning: If the sealing ball shows any signs of surface damage or deformation the entire wire must be discharged and replaced, or water may enter the system and cause a malfunction.

6. Apply a smear of Molykote 111 grease to firing wire port in the operating head and to the rubber seal of the firing wire assembly.
7. Locate the resetting tool in a vice, pins upwards.
8. Locate the two pins into the blind holes on the underside of the operating head. Grip the outside of the operating head. Turn the operating head fully anti-clockwise to expose the circular recess for the metal ball, which can be seen through the wire port in the casing.
9. Push the metal ball of the firing wire into the cable port. Rotate the loading tool clockwise to wind the firing wire into the casing. Then push the sealing ball into place in the port. Continue turning until a click is heard and felt. The Operating Head is now re-set.
10. The loaded indicator arrow on top of the casing will line up to indicate the unit is loaded.

Warning: The operating head must be clicked into the fully loaded position to function. If there is no click to indicate that the operating head is loaded, turn anti-clockwise, remove the cable and reload as above. If there is no click for a second time, discard the operating head and firing wire and replace with new.

Section:	Remedial Actions and Repairs			 OCEAN SAFETY®
DATE:	31/10/2020	CREATED BY:	P.Marlow	
ISSUE:	02/2020	CHECKED BY	J.Beaumont	

M-07-UM-GIST Revision 14 ~ Section 11

5.5.5 ~ Refurbishment of Cylinder Valve after Firing

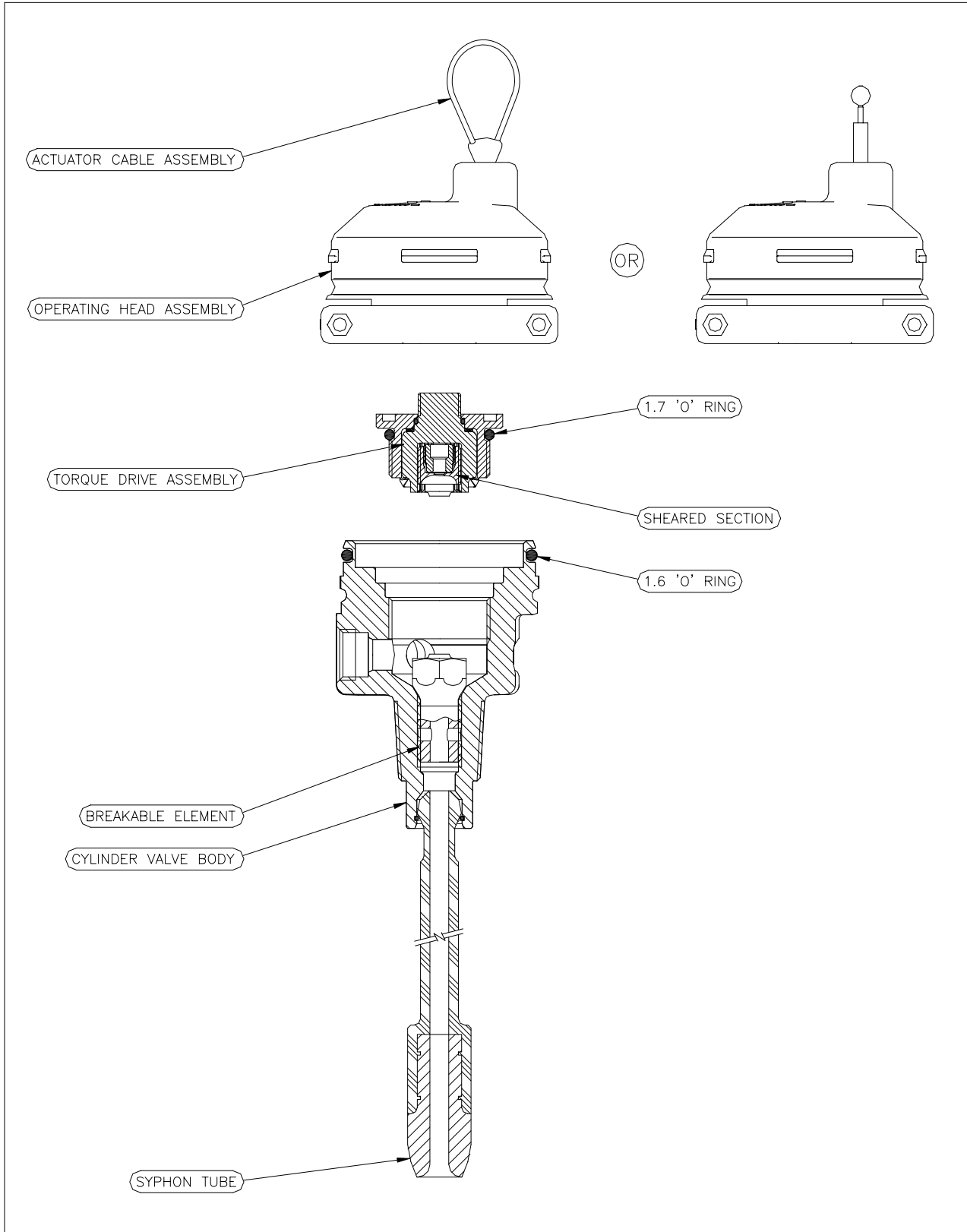

Section:	Remedial Actions and Repairs			
DATE:	31/10/2020	CREATED BY:	P.Marlow	
ISSUE:	02/2020	CHECKED BY	J.Beaumont	

M-07-UM-GIST Revision 14 ~ Section 11

Refurbishment of Cylinder Valve after Firing

1. Check the exterior of Cylinder Valve. Significant areas of pitting are not acceptable.
2. Remove 'O' Ring Flange Seal from Cylinder Valve and discard.
3. Thoroughly clean and dry the Cylinder Valve Body, ensuring no cleaning solution can enter the cylinder.

Warning: Cylinder valve must not be cleaned with solvents, soaps or chemical cleaning agents. These may degrade system components & cause malfunction.

Warning: Cylinder valves must not be reused if there is any significant distortion, corrosion or impact damage or if there is damage to external threads, hose seating surface or break stem seal seating surface .

4. Remove Torque Drive Assembly using the Loading Tool.
5. Replace the 'O' Ring. Lightly grease and fit new 'O' Ring. Use only Dow Corning Molykote 111 silicone grease.
6. After a normal operation it is usual for a broken part of the Break Stem Seal to be retained in the torque coupling. The broken part must be removed. This is best done using a pair of long-nosed pliers.
7. Remove the broken part of the Break Stem Seal Assembly from the Cylinder Valve using a long-series 17mm socket.
8. Fit Torque Drive Assembly, to act as a protective cap until the cylinder is ready to be refilled.
9. Lightly grease and fit new 'O' Ring Flange seal on Cylinder Valve. Use only Dow Corning Molykote 111 silicone grease.
10. Cylinder/Cylinder Valve is now ready for filling in accordance with procedures in Section 6.

Warning: Transit plugs & torque drive assembly must always be fitted to cylinder valve when charged cylinder is stored unconnected to liferaft.

Section:	Remedial Actions and Repairs			 OCEAN SAFETY®
DATE:	31/10/2020	CREATED BY:	P.Marlow	
ISSUE:	02/2020	CHECKED BY	J.Beaumont	

M-07-UM-GIST Revision 14 ~ Section 6

5.5.6 ~ Cylinder Charging Procedure

1. Before fitting, check that the plastic parts of the torque drive assembly rotate smoothly within the brass housing. If they do not, discard and replace with a new assembly.
2. Screw torque drive assembly fully into the cylinder valve body using the “Operating Head Resetting Tool”. Hand tight or torque setting 4Nm (2.95ft/lb) is sufficient.

Warning: Where the cylinder capacity exceeds 20 litres water volume, fit guard ring during transit and handling; unless the cylinders are transported and handled in cassettes.

Warning: Torque drive assembly must be fitted to cylinder valve when charged cylinder is to be handled, transported or stored.

CAUTION: Do Not store charged cylinder in direct sunlight or where temperature can exceed 65°C.

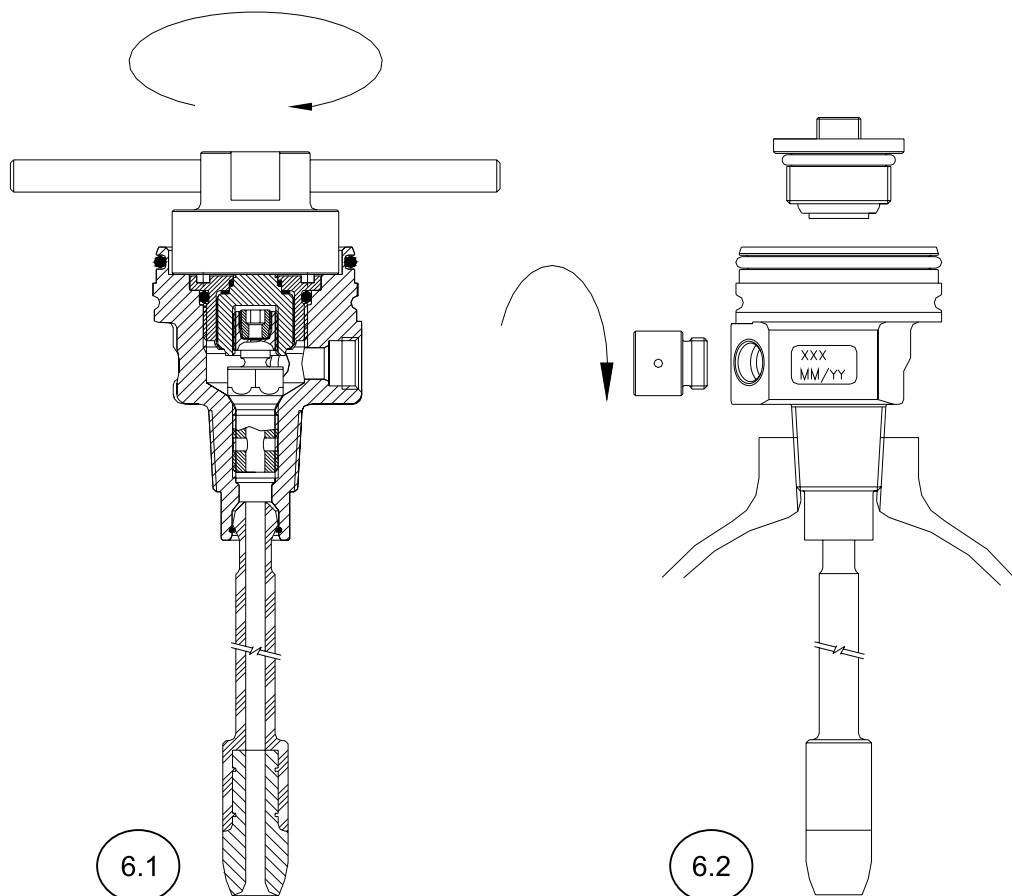

Section:	Remedial Actions and Repairs			 OCEAN SAFETY®
DATE:	31/10/2020	CREATED BY:	P.Marlow	
ISSUE:	02/2020	CHECKED BY	J.Beaumont	

5.5.7 ~ Top Up Valves

Top up valves may be replaced if fault is found with a valve or there are signs of damage to the valve. The Ocean Range of liferafts may be supplied (dependant on age) with either the Airflow top up valve or the A8 Top up valve. Pictures below illustrate the visual differences.



With both valves the workings are in the top section therefore there is no need to cut the tube to replace the valve. Use the appropriate service tool (Airflow valve) or socket (A8 valve) to remove the top section of the valve. Ensure the parts of the valve located on the inside of the tube are retained and not lost in the process. Once the upper part of the valve is removed all loose or damaged parts must be removed from the internal chamber of the bladder. If the internal threaded part is not damaged this may remain inside for the location of the new top part.

Locate the top section of the valve through the exposed hole and into the threaded base. Note the A8 also has an internal washer that must be installed between the internal nut and the fabric. There is a raised section on the washer that must face up towards the fabric Figure 1 below refers. The base requires securing without damaging the fabric of the liferaft. With the valve assembled apply the required torque load to the valve,

- Air Flow Valve 16Nm
- A8 Valve 16Nm

Figure 1 - A8 Top Up Valve

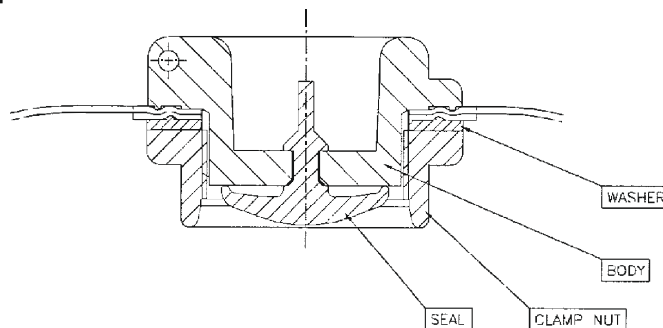

Locate the top section of the valve through the exposed hole and into the threaded base. The base requires securing without damaging the fabric of the liferaft. With the valve assembled apply a torque load of 16Nm to the top section of the valve using the appropriate tool.

Any replacement valves must be checked for air tightness before the valve is re-packed.

Section:	Remedial Actions and Repairs			 OCEAN SAFETY®
DATE:	31/10/2020	CREATED BY:	P.Marlow	
ISSUE:	02/2020	CHECKED BY	J.Beaumont	

5.6 ~ Ocean ISO UltraLite Components

5.6.2 ~ Cylinder Assembly

The cylinder valve has a twin outlet adaptor fitted to the main outlet. If this is found to be loose in service it will require re-bonding using semi permeate thread locker and Loctite 511. Thread locker shall be used to create the bond on the end threads of the cylinder valve, Loctite 511 shall be applied to the first 3 threads of the adaptor to prevent moisture entering the assembly. Fig 5.6 refers. Ensure the threads are cleaned before re-applying any compound.

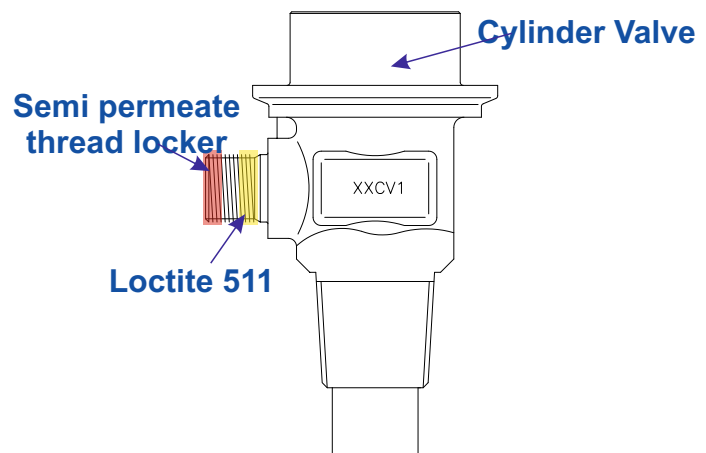
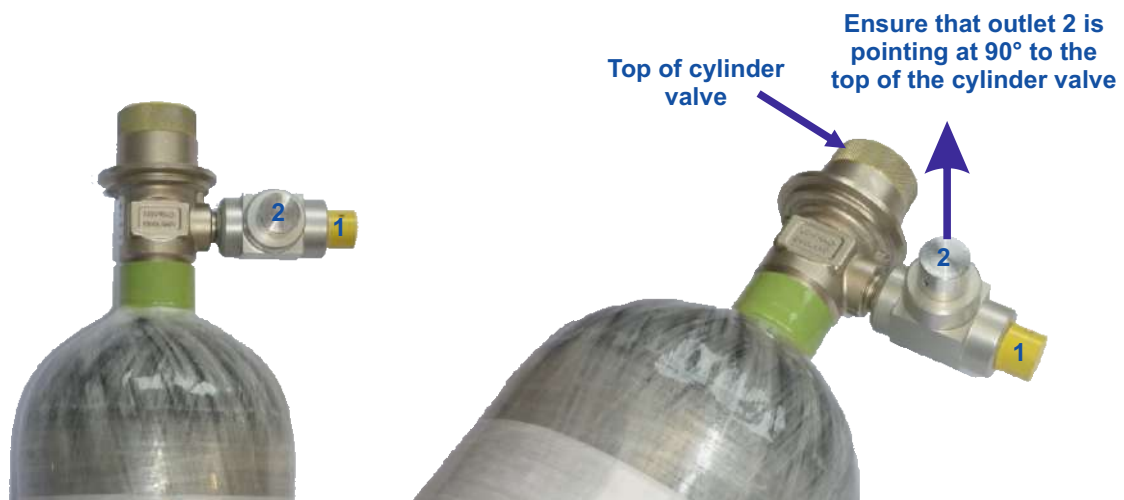



Figure 5.6 - Compound application

Apply the thread locking compound following the manufacturers instructions and reinstall the adaptor. Thread the adaptor and turn it right down to the bottom of the threads. Note that there are 2 outlets on the adaptor, one that runs parallel with the cylinder valve outlet and the other is at 90° to the outlet. Turn the adaptor back so that the outlet at 90° is in the orientation depicted in Fig 5.7.

Figure 5.7 - Twin Outlet Adaptor



Section:	Remedial Actions and Repairs			
DATE:	31/10/2020	CREATED BY:	P.Marlow	
ISSUE:	02/2020	CHECKED BY	J.Beaumont	

LEL-20018 Issue 7 ~ Section 5

5.6.2 ~ GIS Cylinder Valve Installation

Warning: The following checks must be carried out prior to installation of cylinder valve to cylinder.

1. Ensure that the cylinder & cylinder valve threads are compatible & that the cylinder conforms to the standard specified for the working pressure identified on the cylinder valve.
2. Ensure that the Cylinder Valve threads show no visible signs of damage.
3. Ensure that the Syphon Tube (where fitted) is free to swivel and rotate.
4. Ensure that all Cylinder Valve Bores and recesses are clean and free from particles.
5. Ensure that the Sealing Face and Anvil are free from damage and debris.

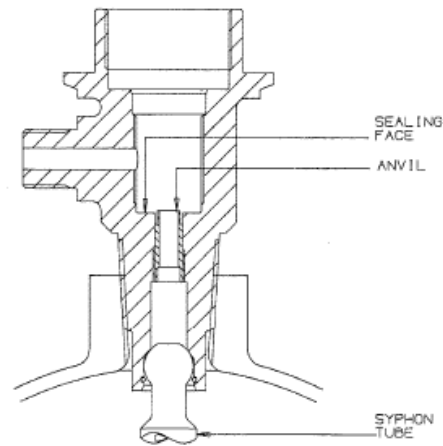

INSTALLATION

6. Sealing material should be applied to the threads as recommended by the LIFE RAFT manufacturer. Tighten Cylinder Valve to a torque of 160-170Nm

Caution: Never insert into the cylinder valve body any implement which could damage the sealing face or anvil.

Warning: Do not exceed the recommended torque or attempt to further tighten the cylinder valve once the gas bottle is charged as this could cause failure of the valve.

Section:	Remedial Actions and Repairs			 OCEAN SAFETY®
DATE:	31/10/2020	CREATED BY:	P.Marlow	
ISSUE:	02/2020	CHECKED BY	J.Beaumont	

LEL-2008 Issue 7 ~ Section 7

5.6.3 ~ Fitting Penetrator Assembly

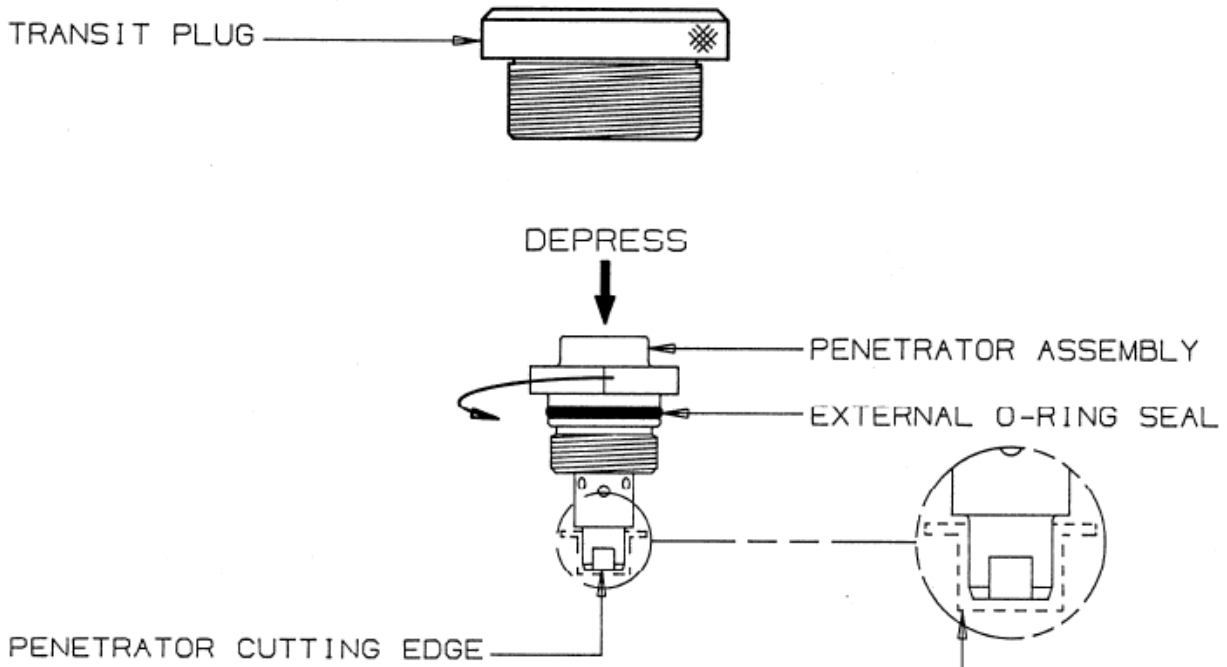

WARNING:
 PROTECTIVE CAP MUST
 BE REMOVED WHEN
 PENETRATOR ASSEMBLY
 IS FITTED.

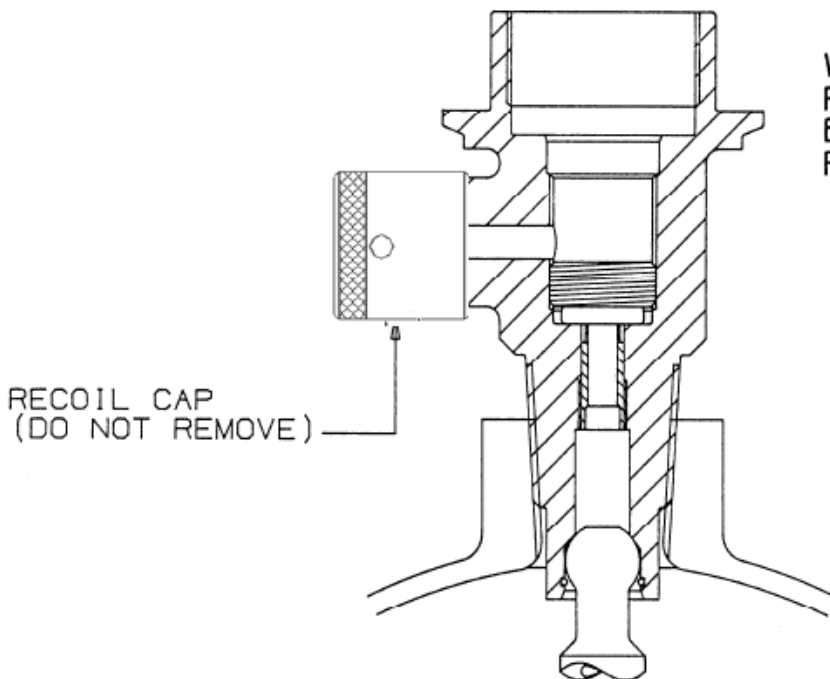

Section:	Remedial Actions and Repairs			
DATE:	31/10/2020	CREATED BY:	P.Marlow	
ISSUE:	02/2020	CHECKED BY	J.Beaumont	

LED-2008 Issue 7 ~ Section 7

Fitting Penetration Assembly

1. Remove Transit Plug from Cylinder Valve.

Warning: Do not remove recoil cap.

2. Remove protective cap from Penetrator Assembly.

3. Visually inspect penetrator blade to ensure there is no damage to cutting edge. Plug Gauge must freely enter and move in bore of penetrator.

Warning: If plug gauge does not enter penetrator or if penetrator shows signs of significant damage, penetrator assembly must be discarded & replaced.

4. Depress penetrator shaft to ensure freedom of movement.

5. Ensure external 'O' Ring is in good condition. Smear with a thin film of Molykote 111 grease.

6. Fit Penetrator Assembly into Cylinder Valve and tighten to a torque of 25Nm using suitable 24mm A/F spanner and torque wrench.

Warning: Never insert any implement into cylinder valve or push down penetrator shaft when penetrator assembly is fitted as this could cause violent gas discharge.

7. Re-fit Transit Plug.

Caution: Transit plug should be fitted to cylinder valve when charged cylinder is to be handled, transported or stored with penetrator fitted, to prevent ingress of dirt.

Caution: Do not store charged cylinders in direct sunlight or where temperatures can exceed 65°C.

Section:	Remedial Actions and Repairs			 OCEAN SAFETY®
DATE:	31/10/2020	CREATED BY:	P.Marlow	
ISSUE:	02/2020	CHECKED BY	J.Beaumont	

LEL-2008 Issue 7 ~ Section 8

5.6.4 ~ GIS Assembly of Operating Head to Cylinder Valve

1. If fitted, remove Transit Plug fro cylinder valve.

Warning: Do not remove recoil cap.

2. Apply a thin film of Molykote 111 grease to 'O' Ring flange seal & fit to neck of cylinder valve.

Warning: Ensure that 'O' Ring seal is correctly lubricated & fitted as this is a critical item to prevent ingress of water.

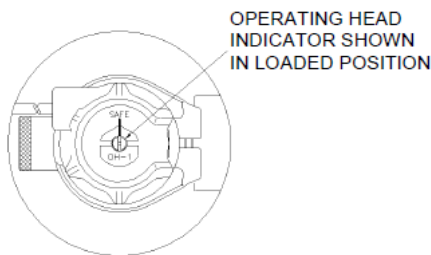
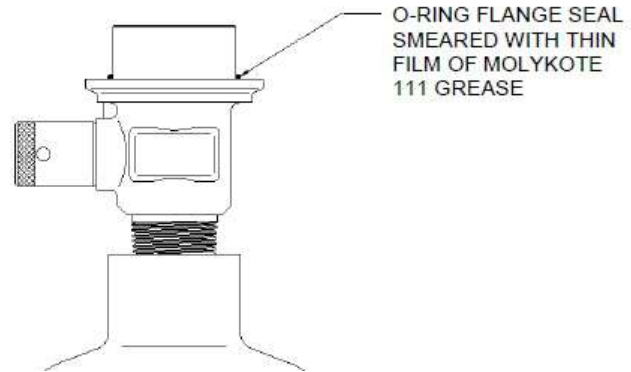

3. Check that the operating head is loaded. Screwdriver shot must be in line with SAFE marking as shown. If not, reload.

Warning: Operating head must be correctly loaded or system will not function.

4. Locate Operating Head onto Cylinder valve. Push fully home before proceeding to fit clamp.

5. Fit clamp & retain nut with a suitable Ø6mm rob until screw is initially engaged tightens using a Pozidriv No.2 screwdriver so the Operating Head can just be rotated by hand on Cylinder valve. Align Operating Head as required.

6. Tighten screw further until rotation of the operating Head is just prevented. Tighten a further one turn. **DO NOT OVER TIGHTEN.** This will leave a gap as shown in next diagram depending on the type of clamp fitted/

7. Clamp Type B: If the Operating Head is being reused, it is possible that the clamp has previously been over-tightened & stretched. In this case it is acceptable to tighten beyond the nominal gap shown in next diagram to ensure the operating Head cannot rotate on the cylinder Valve.

Section:	Remedial Actions and Repairs			 OCEAN SAFETY®
DATE:	31/10/2020	CREATED BY:	P.Marlow	
ISSUE:	02/2020	CHECKED BY	J.Beaumont	

LEL-2008 Issue 7 ~ Section 8

GIS Assembly of Operating Head to Cylinder Valve

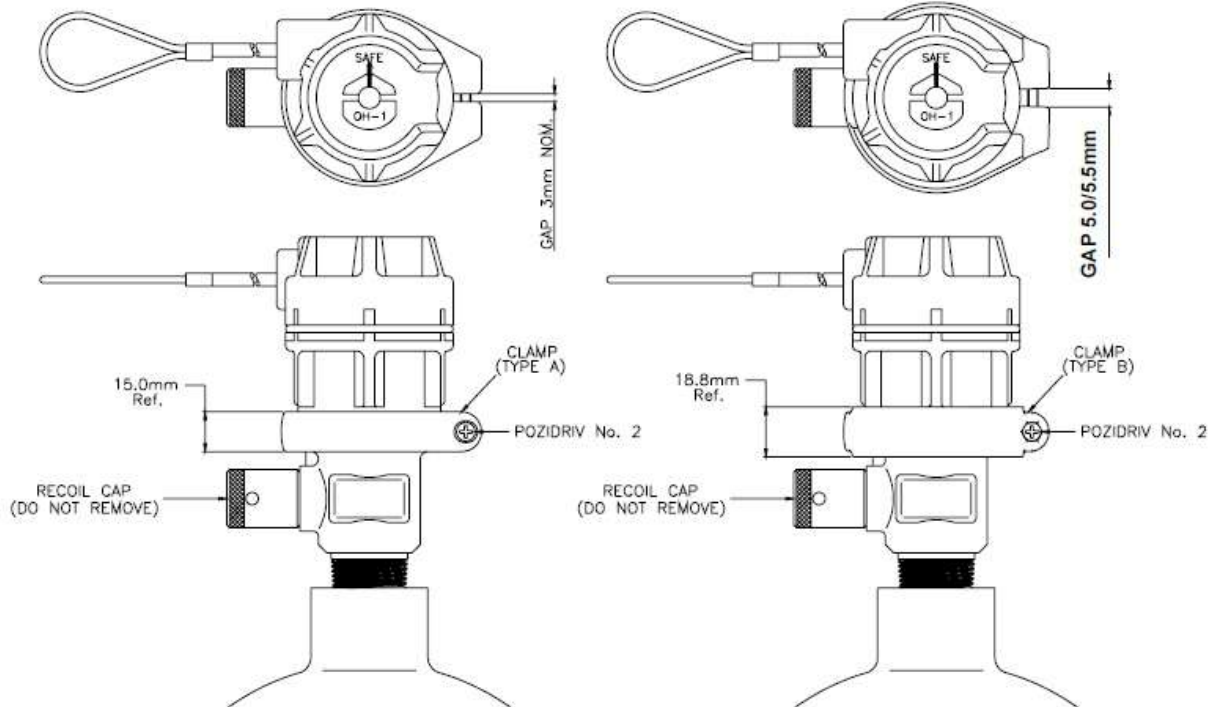

CAUTION: The clam faces will not meet when the screw is tightened. A gap will be evident, nominally as shown above. Do not over tighten screw.

CAUTION: Do not store charged cylinders in direct sunlight or where temperature can exceed 65°C.

Note: For GIS Valves on Ultralite liferafts in the new style containers the firing wire will be of the twin ball type.

Section:	Remedial Actions and Repairs			 OCEAN SAFETY®
DATE:	31/10/2020	CREATED BY:	P.Marlow	
ISSUE:	02/2020	CHECKED BY	J.Beaumont	

LEL-2008 Issue 7 ~ Section 12

5.6.5 ~ GIS Resetting of Operating Head after Firing
 Figure 12:

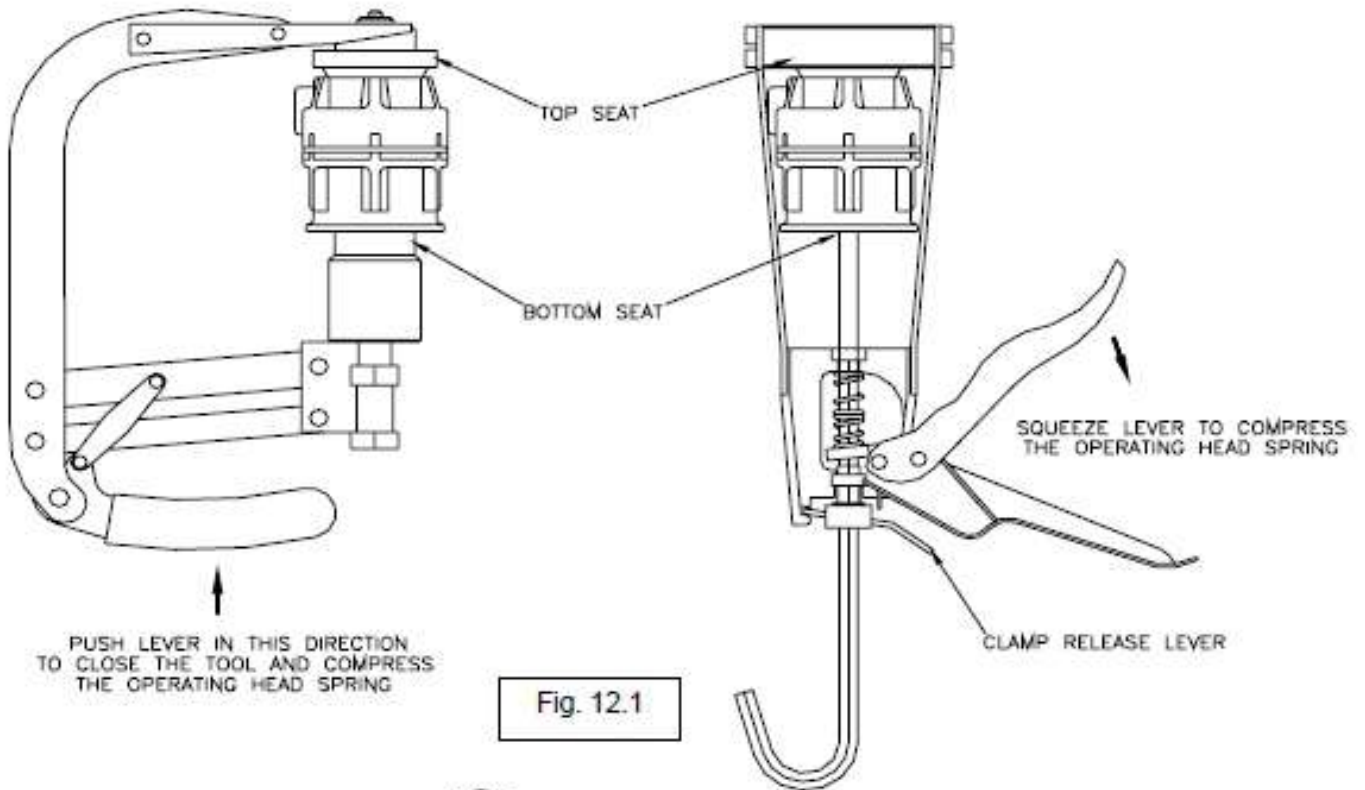

Fig. 12.1

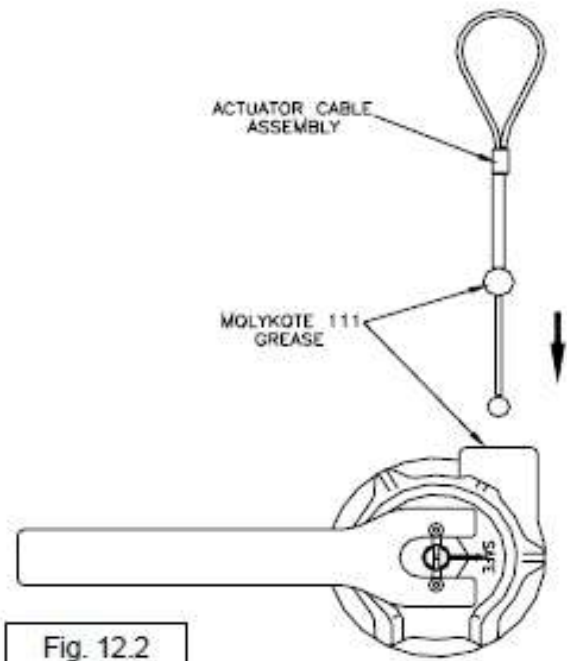

Fig. 12.2

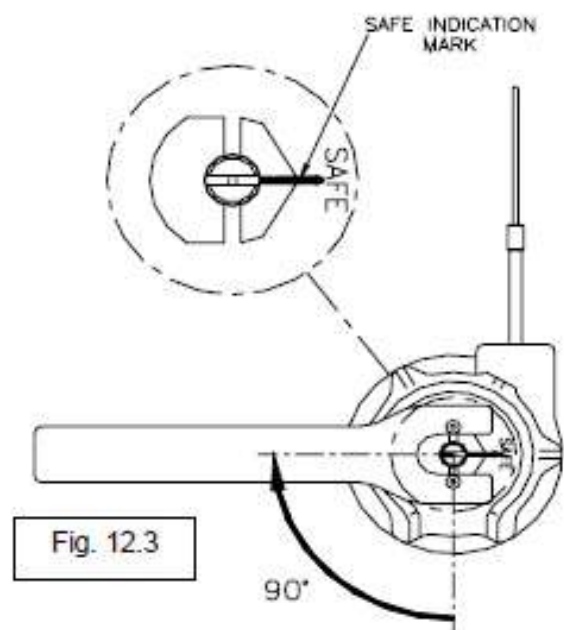



Fig. 12.3

Section:	Remedial Actions and Repairs			
DATE:	31/10/2020	CREATED BY:	P.Marlow	
ISSUE:	02/2020	CHECKED BY	J.Beaumont	

LEL-2008 Issue 7 ~ Section 12

GIS Resetting of Operating Head after Firing

1. Remove the clamp retaining Operating Head to Cylinder Valve. Remove Operating Head from Cylinder Valve.
2. Visually examine Operating Head. Discard if damaged or more than 15 years old.
3. An Operating Head previously used **MUST** be flushed through with clean water and dried thoroughly in air.

Note: WD40 can be applied to the Operating Head mechanism to prevent surface corrosion if used regularly in training.

WARNING: Operating Head must not be cleaned with solvents, soaps or chemical cleaning agents. These may degrade system components & cause malfunction.

4. Locate Operating Head into Top Seat of Loading Tool. (Fig. 12.2 refers)
5. Compress Operating Head spring by pushing Loading Tool lever fully home or squeezing handles 3-4 times (depending on Loading Tool used), ensuring that Bottom Seat enters fully into Operating Head. Take care not to scratch chamfered entrance of plastic body. (Fig. 12.2 refers)
6. Visually examine Actuator Cable Assembly for condition of crimp, ball end and sealing ball. Discard if damaged. (Fig. 12.2 refers)

WARNING: If sealing Ball shows any signs of surface damage or deformation the entire cable must be replaced, or water may enter the system & cause malfunction.

7. Apply a smear of Molykote 111 grease to cable port in Operating Head and to rubber ball seal of Actuator Cable Assembly. Push the rubber ball seal away from the metal ball end, up to the plastic sleeve. Insert Actuator Cable into cable port in Operating Head.

8. Using a suitable, parallel tip screwdriver turn screwdriver slot in top of Operating Head **CLOCKWISE** through 90° to pull in Actuator Cable and reset Operating Head. (Fig. 12.3 refers)

9. Unclamp Loading Tool and remove Operating Head.

10. Ensure the screwdriver slot is aligned with the SAFE mark.

WARNING: Operating Head must be correctly loaded or system will not function.

11. Fit Safety Pin, if required.

12. Store in a clean, dry place until required.

Section:	Remedial Actions and Repairs			 OCEAN SAFETY®
DATE:	31/10/2020	CREATED BY:	P.Marlow	
ISSUE:	02/2020	CHECKED BY	J.Beaumont	

LEL-2008 Issue 7 ~ Section 13

5.6.6 ~ GIS Refurbishment of Cylinder Valve after Firing

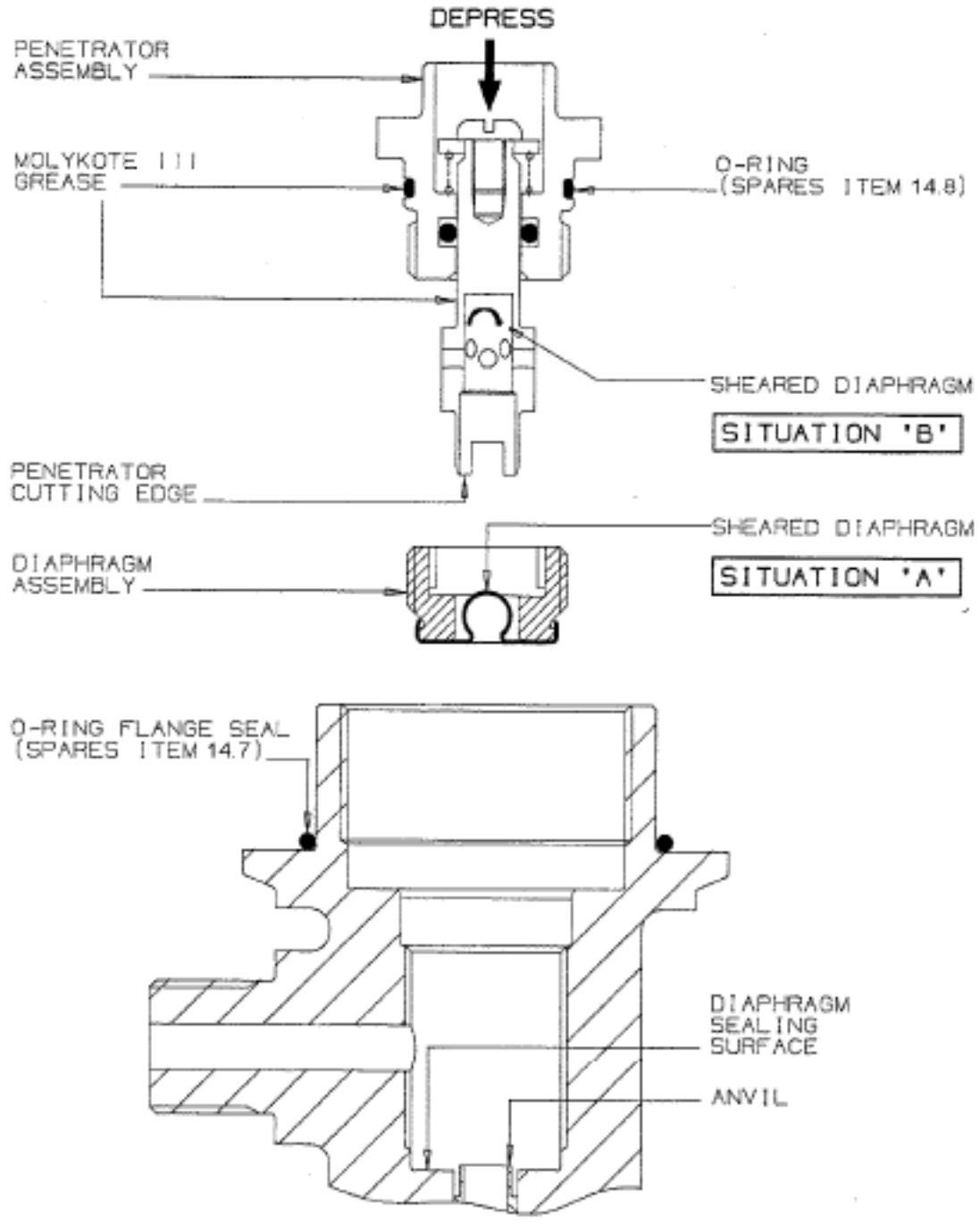

Section:	Remedial Actions and Repairs			
DATE:	31/10/2020	CREATED BY:	P.Marlow	
ISSUE:	02/2020	CHECKED BY	J.Beaumont	

LEL-2008 Issue 7 ~ Section 13

GIS Refurbishment of Cylinder Valve after Firing

1. Visually examine exterior of Cylinder Valve. Significant areas of exposed base metal (brass) or green corrosion are not acceptable.

2. Remove Penetrator Assembly, Diaphragm Assembly and 'O' Ring Flange Seal from Cylinder Valve. Discard 'O' Ring Flange Seal and external 'O' Ring on Penetrator Assembly, taking care not to damage the Penetrator Assembly 'O' Ring groove.

3. Thoroughly clean and degrease Cylinder Valve Body, ensuring no cleaning solution can enter the cylinder.

WARNING: Cylinder Valve must not be reused if there is any significant distortion, corrosion or impact damage or if there is damage to external threads, hose seating surface, diaphragm seating surface or anvil.

4. Establish if sheared diaphragm is Situation 'A' or Situation 'B'. In either situation the Diaphragm Assembly **MUST** be discarded. After a normal operation it is usual for the sheared diaphragm to be retained as shown in Situation 'A'. However, sometimes the cut element of the diaphragm may be lodged within the Penetrator as shown in Situation 'B'.(Fig.13.1 refers)

CAUTION: The Penetrator assemble may be reused if it has no more then 5 firings & is less than 15 years old. Otherwise it must de discarded & replaced with new.

5. If the Penetrator Assembly is to be reused, then the following actions **MUST** be carried out:

5.1 The sheared diaphragm, if in Situation 'B', must be carefully removed. This is best done using a pair of fine-nosed tweezers, with care being taken not to damage the cutting edge of the penetrator.

5.2 Clean Penetrator Assembly in clean water and dry thoroughly in air.

WARNING: Penetrator assembly must not be cleaned with solvents, soaps or chemical cleaning agents as this can degrade the components. Do not attempt to dismantle Penetrator assembly - This item is not serviceable,

5.3 Visually inspect penetrator blade to ensure there is no damage to the cutting edge. Plug Gauge must freely enter and move in the bore of the penetrator.

5.4 Depress penetrator shaft (in direction of arrow in fig. 13.1) to ensure freedom of movement and apply a thin film of Molykote 111 as shown.

5.5 Replace 'O' Ring with NEW Smear with a thin film of Molykote 111 grease and fit as shown, taking care not to damage 'O' Ring.

WARNING: If plug gauge does not enter Penetrator or if Penetrator shows signs of significant damage, penetrator assembly must be discarded & replaced with new.

Section:	Remedial Actions and Repairs			
DATE:	31/10/2020	CREATED BY:	P.Marlow	
ISSUE:	02/2020	CHECKED BY	J.Beaumont	

LEL-2008 Issue 7 ~ Section 13

GIS Refurbishment of Cylinder Valve after Firing.

6. Fit NEW Diaphragm Assembly and charge the cylinder..

7. Fit Penetrator Assembly.

8. Cylinder/Cylinder Valve is now ready for fitting of Operating Head and installation to liferaft

9. Fit a new 'O' Ring flange seal to Cylinder Valve body.

WARNING: Recoil cap must always be fitted to Cylinder Valve outlet when charged cylinder is stored unconnected to liferaft.

CAUTION: Transit plug should be fitted to cylinder valve when charged cylinder is to be handled, transported or stored with Penetrator Assembly fitted.

CAUTION: Do not store charged cylinder in direct sunlight or where temperature can exceed 65°C.

Section:	Remedial Actions and Repairs			
DATE:	31/10/2020	CREATED BY:	P.Marlow	
ISSUE:	02/2020	CHECKED BY	J.Beaumont	

5.7 ~ Ancillary Equipment

5.7.1 ~ Drogue & Line

If there is damage to the line of the sea anchor the entire length shall be replaced. The line is supplied cut to length direct from Ocean Safety. The line is sourced to comply with ISO 9650:1 2005. Only Ocean Safety parts may be assembled to the liferaft.

When connecting the line to the drogue, the line must be spliced on the webbing of the drogue. Do not use knots to fasten the line to the drogue.

If damage is present on mesh or the webbings of the drogue, the whole unit shall be replaced.

5.7.2 ~ Safety Knife / Whistle

Check the blade for signs of surface rust may be cleaned using abrasive paper. Anything more than surface rust will deem the part unfit for purpose and will require replacement.

Check that the whistle operates correctly & it is secured with a lanyard.

Any units showing signs of damage are to be replaced with Ocean Safety supplied spares.



5.6.3 ~ Quiot & Line

Check that the line is attached to the raft & that it is neatly coiled up with the quiot are secured within the pouch provided.



Section:	Remedial Actions and Repairs			
DATE:	31/10/2020	CREATED BY:	P.Marlow	
ISSUE:	02/2020	CHECKED BY	J.Beaumont	

5.6.4 ~ Containers fitted with Guides

Both the Mk2 Containers & Ultralite Containers have guides fitted.

The container is fitted with four guides on the lower section of the container. If one or more are damaged or missing they must be replaced before re-packing may commence.

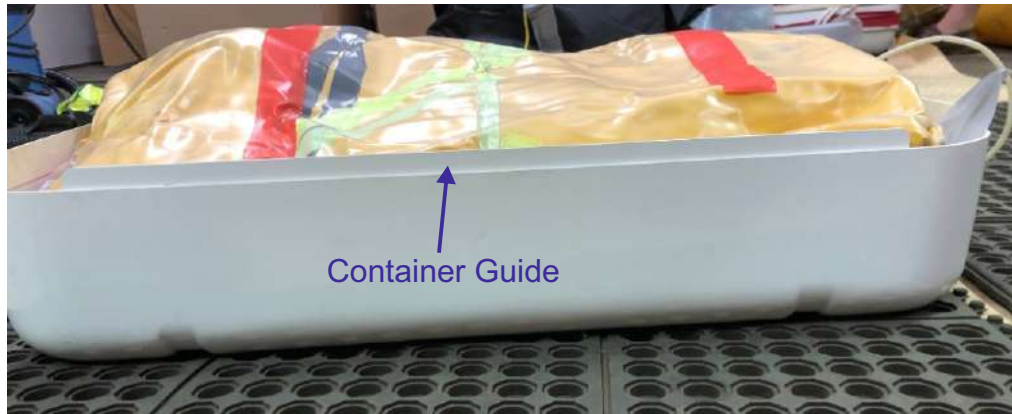

To replace the guides the bonding area must be dry and clean of all debris. Any broken guides are to be removed along with all adhesive residues. Clean the surface using solvent such as acetone - **Ensure protective equipment is worn while working with solvents or power tools.**

All surfaces for bonding require a key and cleaning with solvent before adhesive is applied. Re-bond the guides a high strength fast curing two part epoxy adhesive. Do not let the guides slip during curing time. Take care not to apply excessive adhesive at the containers mating edge. Follow the specific instructions for the adhesive use noting the cure times, required cavity depth and working time.

Section:	Remedial Actions and Repairs			 OCEAN SAFETY®
DATE:	31/10/2020	CREATED BY:	P.Marlow	
ISSUE:	02/2020	CHECKED BY	J.Beaumont	

5.8 ~ Torque Setting

The following are the various torque setting for the Ocean ISO Liferaft range.

Componet	Newton Meters	Feet Pounds
M24 Nut	30.0Nm	(22.1 ft.lb)
Fitting Hose to Cylinder Valve	12.2Nm	9.00 ft.lb
GIST Op. Head Bolts	1.12Nm	0.83 ft.lb
B10 PRV (initial setting)	25.0Nm	18.44 ft.lb
B10 PRV (After 12 Hours)	29.0Nm	21.39 ft.lb
A8 Top-up Valve	16.0Nm	21.39 ft.lb
M16 Quick-Fit Connector Body	20.0Nm	15.00 ft.lb
M16 Nut Inlet Valve	9-12Nm	6.64-8.85 ft.lb
Torque Drive Assembly	4.0Nm	2.95 ft.lb
Cylinder Valve	160-170Nm	119-125 ft.lb
Break Stem Assembly	40.0Nm	29.5 ft.lb
GIS Diaphragm Assembly	35-40Nm	25.81-29.50 ft.lb
GIS Penetrator Assembly	25.0Nm	18.44 ft.lb

Section:	Remedial Actions and Repairs			
DATE:	31/10/2020	CREATED BY:	P.Marlow	
ISSUE:	02/2020	CHECKED BY	J.Beaumont	

Section ~ 5

Remedial Action & Repairs

Ocean ISO / Ocean ISO Ultralite Liferrafts

Including the Mk2 Container

Section:	Remedial Actions and Repairs			
DATE:	31/10/2020	CREATED BY:	P.Marlow	
ISSUE:	02/2020	CHECKED BY	J.Beaumont	

5 ~ Remedial Actions and Repairs

5.1 ~ Introduction

5.2 ~ Adhesives

5.2.1 ~ Storage Instructions

5.2.2 ~ Mixing Instructions

5.2.3 ~ Application of Adhesive

5.3 ~ Fabric Repairs

5.4 ~ Cordage

5.5 ~ Replacement of Component Parts

5.5.1 ~ Pressure Relief Valve

5.5.2 ~ Inlet Valve

5.5.3 ~ GIST Cylinder Valve Installation

5.5.4 ~ GIST Operating Head, Resetting Procedure

5.5.5 ~ GIST Refurbishment of Cylinder Valve after Firing.

5.5.6 ~ GIST Cylinder Charging Procedure

5.5.7 ~ Top Up Valve

5.6 ~ Ocean ISO Ultralite Components

5.6.1 ~ Cylinder Assembly

5.6.2 ~ GIS Cylinder Valve Installation

5.6.3 ~ GIS Fitting Penetrator Assembly

5.6.4 ~ GIS Assembly of operating Head to Cylinder Valve

5.6.5 ~ GIS Resetting Operating Head after Firing

5.6.6 ~ GIS Refurbishment of Cylinder Valve after Firing

5.7 ~ Ancillary Equipment

5.7.1 ~ Drogue & Line

5.7.2 ~ Safety Knife / Whistle

5.7.3 ~ Quoit & Line

5.7.4 ~ ISO Mk2 & Ultralite Container

5.8 ~ Torque Settings

Section:	Remedial Actions and Repairs			
DATE:	31/10/2020	CREATED BY:	P.Marlow	
ISSUE:	02/2020	CHECKED BY	J.Beaumont	

5.1 Introduction

The following section defines the scope and procedures for repairs on the Ocean Safety Ocean ISO Liferaft. All replacement parts or adhesives used on the liferaft shall be Ocean Safety approved spares.

Any part of the liferaft or equipment that is found to be damaged or non functional during the process of inspection and testing requires remedial action to be taken. Any part of the liferaft or ancillary equipment that can not be repaired within the parameters of this manual or appropriate manufactures owner's manual must be replaced using Ocean Safety supplied spares.

5.2 ~ Adhesives

Repairs to the Fabric of the liferaft shall only be undertaken using adhesive supplied by Ocean Safety:- Bostik 2402, Bostic NE486, Bostic 1400 or Apollo A3480

Warning - Adhesives shall be used in accordance with the manufactures instructions and only used in areas of the liferaft permitted by this manual.

Warning - Only use adhesive in well ventilated areas. Use the appropriate personal safety equipment when working with adhesives.

5.2.1 ~ Storage instructions

Apollo adhesives and hardeners have a shelf life of 12 months from the date of manufacture. Adhesives and hardeners shall be stored in the container provided and shall be stored with the supplied lid securely located.

The adhesive and hardener shall be stored in a clean dry place out of direct sun light. The storage condition of the adhesive and hardener shall not exceed 25°C and not fall below 10°C. Any adhesive or hardener that is stored outside the prescribed parameters must be disposed of in accordance with local laws.

Before using a batch of adhesive, the condition of the solution shall be checked for:

- An increase in viscosity (usually caused by an incorrectly fitted lid)
- signs that the adhesive has separated leaving a way residue over the surface of the missus
- Cloudiness or crystallisation of the hardener

if any of the above are found on inspection of the adhesive or hardener, the affected part shall not be used for repairs. The adhesive and/or hardener shall be disposed of in accordance with local laws.

Section:	Remedial Actions and Repairs			
DATE:	31/10/2020	CREATED BY:	P.Marlow	
ISSUE:	02/2020	CHECKED BY	J.Beaumont	

5.2.2 ~ Mixing Instructions

Prior to any measuring out of required adhesive, the sediment at the bottom of the holding container shall be mixed back into the main body of the adhesive.

Measure out the desired quantity of adhesive. Measure out equivalent 4% mass of hardener and add it to the pot.

The mixing of the adhesive with the hardener shall be performed in lacquered, glass or polythene containers. Ensure that containers are clean and dry prior to mixing. With both parts in one pot, stir the mixture for a minimum of 5 minutes. When the mixed adhesive is not in use, cover the pot to maintain a good pot life. Pot life of mixed adhesive is dependant on conditions, pot life of up to one hour is achievable. Once the adhesive becomes stringy on application, replace the adhesive.

5.2.3 ~ Application of Adhesive

Prior to the application of adhesive on fabric, the fabric shall be cleaned and prepared. Great care is required to ensure that the fabric is clean of debris and grease. Bonding interfaces shall be cleaned with toluene to ensure the fabric is clean. All surfaces must be completely dry with all solvent evaporated before adhesive may be applied.

Adhesive shall be applied using a brush with a wooden handle and natural fibre brushes. To apply the adhesive use a clean brush with a width of 25mm and a bristle length of 30mm. for woven fabrics three layers of adhesive are required. The first two layers are to be worked into the weave of the textile. The third should be used to finish with a smooth layer. Sufficient time shall be given between layers to allow the adhesive to become touch dry on the first two layers. This time will change with ambient conditions. on the third coat the two parts being bonded shall be brought together whilst the adhesive is tacky to the touch.

Warning - When applying and checking adhesive do not use finger tips. This will contaminate the adhesive. Use the back of a finger to touch the fabric. Keep contact to a minimum.

When bringing the two surfaces together the two parts must be lined up before contact is made. Once the pieces come together they may not be repositioned. if parts are not aligned correctly they must be pulled apart and the process repeated.

Once parts are correctly positioned, the bond shall be consolidated using a spatula or heavy roller. Work from the inside out and remove any air bubbles created when bringing the two layers together.

Section:	Remedial Actions and Repairs			
DATE:	31/10/2020	CREATED BY:	P.Marlow	
ISSUE:	02/2020	CHECKED BY	J.Beaumont	

5.3 ~ Fabric Repairs

An approved service station is required to hold stock of suitable coated fabric for repair patches. Any repair patch shall be cut from a fabric the same colour as the area being repaired. Fabric can be supplied as a service spare from Ocean Safety.

For the application of adhesive to patch and liferaft refer to section 5.2.3. All patches shall be checked for air holding capability following the required cure period of 72 hours. Any patches that are found to be leaking shall be reworked.

Use a circular patch to repair pin holes - minimum diameter 50mm

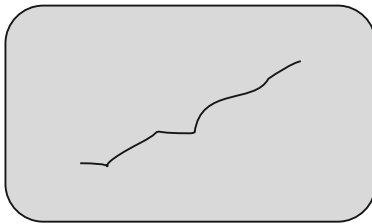
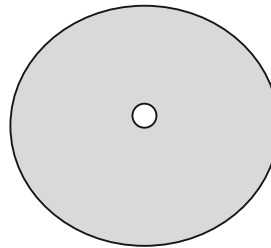

Use a rectangular patch to repair tears. The patch shall be a minimum of 25mm in width from the outside edge of the tear.

Use an L shaped patch may be used to cover striking tears. The patch shall be a minimum of 25mm in width from the outside edge of the tear.

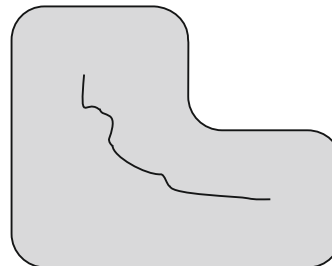

5.4 ~ Cordage

Any repairs to the cordage of the liferaft must be performed using a sewing machine. Repair by hand sewing is not permitted.

All liferafts repaired using a sewing machine shall be pressure tested in accordance with the airholding test procedure

Section:	Remedial Actions and Repairs			
DATE:	31/10/2020	CREATED BY:	P.Marlow	
ISSUE:	02/2020	CHECKED BY	J.Beaumont	

5.5 ~ Replacement of Component Parts

5.5.1 ~ Pressure Relief Valves

Due to the design of the PRV's, most leaks are evident from the centre of the valve. This makes an assessment of the root cause difficult. Both a loose valve and an issue with the sealing faces would result with a leak through the centre of the valve.

Firstly check the torque setting for the valve - Note this check shall be performed before any water or other lubricants are used. Using a torque wrench and the B10 tool, confirm the torque is set to **29Nm**.

If the torque is correctly set and the issue remains, inspect the sealing faces. Remove any debris with water.

If damage is located on the sealing faces, or the cleaning of the valve does not resolve the issue, the valve will require replacement.

The pressure relief valve is made up of two parts that are located internally and externally of the buoyancy tube. The valve can be removed by unscrewing the outer section of the valve using either the service spanner.

To replace a pressure relief valve both parts of the valve are to be removed. To retrieve the bottom half of the valve the old patch must be cut to gain access to the internal parts. A replacement valve shall be installed on a replacement patch to the correct torque ready for attachment the buoyancy tube. For torque setting, please refer to appendix 2.

The doubler patch is to be bonded into the required position following the procedure detailed in section 5.2.3. A doubler patch shall be consolidated correctly using a boning tool or roller. All patches must be checked for air holding capability following a minimum cure period of 72 hours. Any patches that fail the air holding test shall be reworked.

Section:	Remedial Actions and Repairs			 OCEAN SAFETY®
DATE:	31/10/2020	CREATED BY:	P.Marlow	
ISSUE:	02/2020	CHECKED BY	J.Beaumont	

5.5.2 ~ Inlet Valves

Extract from manufacture's manual M-07-IS-GIVT

- Gas Inflation System (Torsional) Inlet Valve Installation Instructions

Gas Inflation System (Torsional) Inlet Valve Installation Instructions

M-07-IS-GIVT
09/04/2014
Revision 8

1. Part List

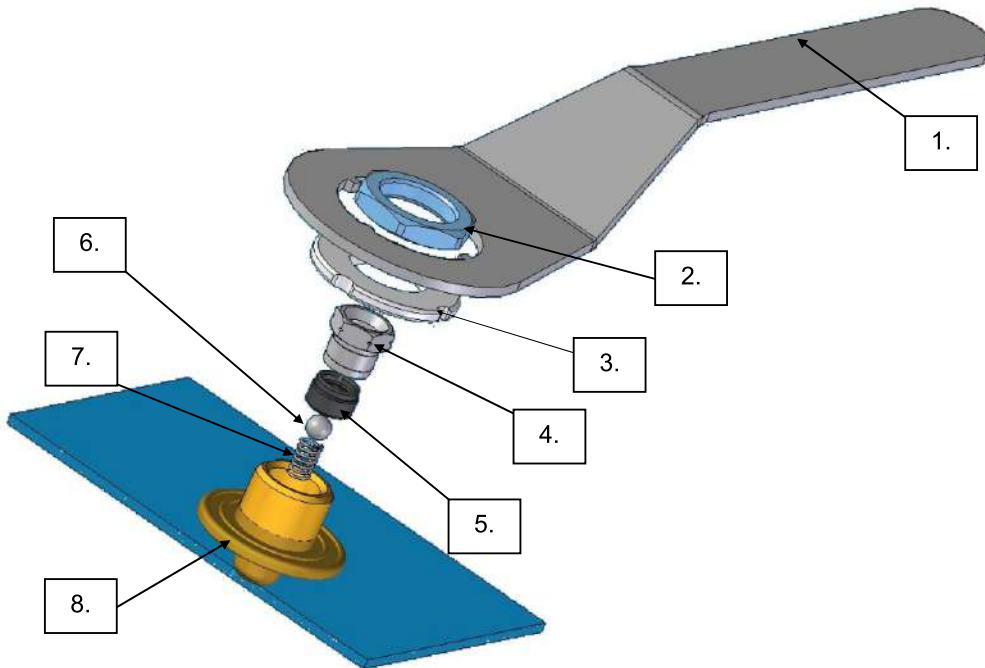

Item No:	Part No:	Description
1	0320000	Spanner
2	B15671 B15420	M24 Nut M24 Nut (Unplated)
3	17675	Plastic Washer
4	32400010 0806001	M16 Quick-Fit Connector Body M16 Quick-Fit Connector Body (Stainless Steel, Purple code)
5	18271	Ball Seat
6	03800016	Sealing Ball
7	19236	Spring
8	Various	Valve Body

Section:	Remedial Actions and Repairs			 OCEAN SAFETY®
DATE:	31/10/2020	CREATED BY:	P.Marlow	
ISSUE:	02/2020	CHECKED BY	J.Beaumont	

M-07-IS-GIVT Revision 8

Gas Inflation System (Torsional) Inlet Valve Installation Instructions

2. Installation

Tools required for this operation:

- 1 x GIST inlet valve spanner
- 1 x 33mm A/F Spanner

1. Cut a 24.5 / 24.0 mm diameter hole in the fabric. Push the M24 threaded section of the inlet valve body through the hole in the tube fabric.

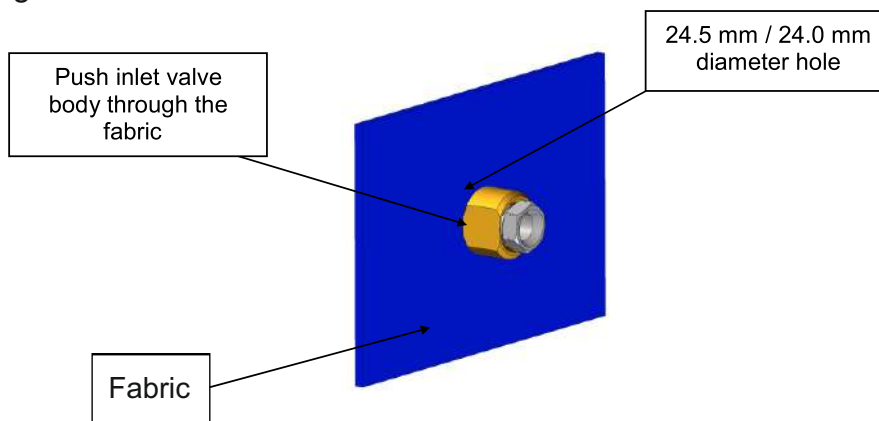

2. Place the washer over the M24 x 1.5 thread, ensuring that the flats line up.

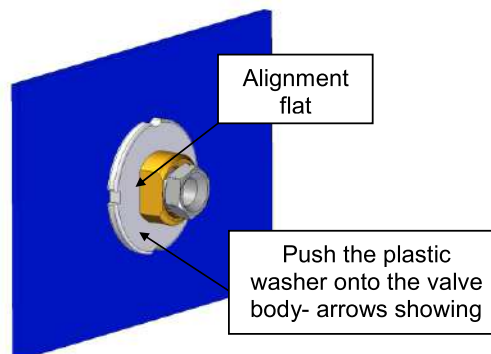

3. Locate the nut onto the inlet valve body and spin down the thread. Tighten hand tight.

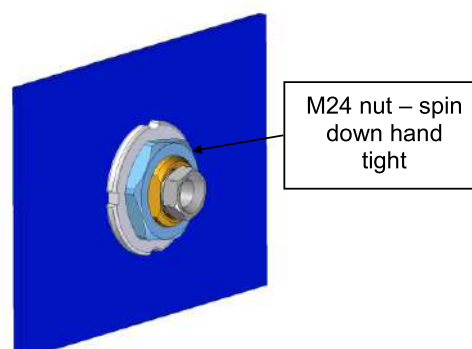

Section:	Remedial Actions and Repairs			 OCEAN SAFETY®
DATE:	31/10/2020	CREATED BY:	P.Marlow	
ISSUE:	02/2020	CHECKED BY	J.Beaumont	

M-07-IS-GIVT Revision 8

4. Locate the inlet valve spanner into the 4 locations on the outside diameter of the Washer. Align the jets in the inlet valve by ensuring the arrows on the spanner are orientated along the longitudinal axis of the tube.

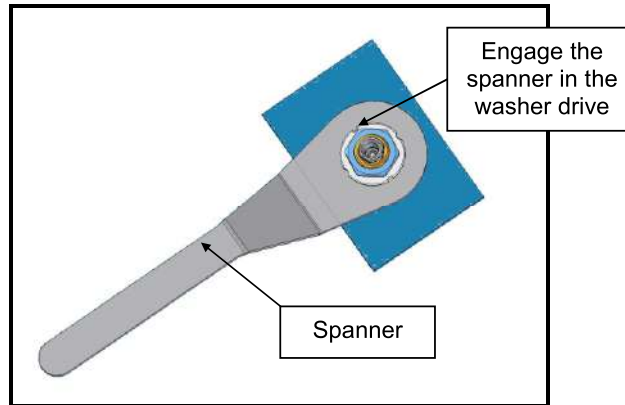

5. Locate a 33mm A/F socket and torque wrench on the M24 nut. Tighten the M24 nut to a torque of 30Nm (22.1 ft/lbs).

6. Remove the red plastic dust cap from the top thread of the inlet valve. The valve is now ready to accept the quick fit connector on the end of the high pressure hose. Push the connector firmly into the hole, make sure a click is heard and then rotate through 90 degrees. Check that the connection has been correctly made by pulling the hose connector firmly upwards, away from the valve.

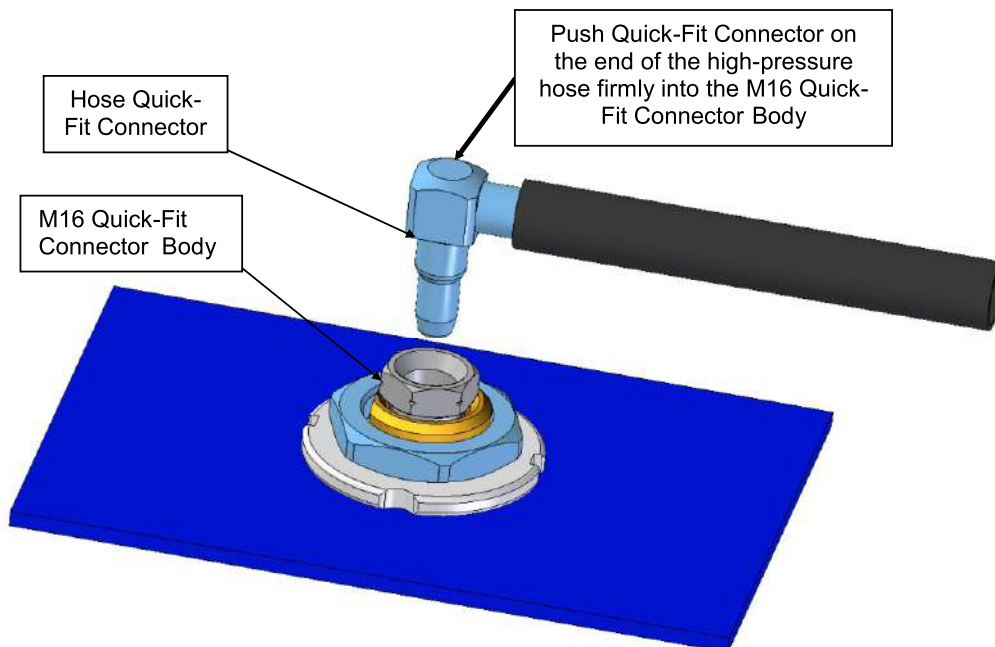

7. If the hose has not been correctly snapped into place it may blow out during inflation. In this case check that the 'O' Ring is still in place in the M16 Quick-Fit Connector Body before pushing together as described. If it is not present replace the M16 Quick-Fit Connector Body.

Section:	Remedial Actions and Repairs			 OCEAN SAFETY®
DATE:	31/10/2020	CREATED BY:	P.Marlow	
ISSUE:	02/2020	CHECKED BY	J.Beaumont	

M-07-IS-GIVT Revision 8

3. Service Instructions

3.1 If the valve is leaking from around the M16 Quick-Fit Connector Body or if the hose needs replacing:

Tools required for this operation:

- 1 x 16mm A/F spanner
- 1 x GIST inlet valve spanner
- Mild detergent
- Warm water

1. Engage the inlet valve spanner into the 4 locations on the outside diameter of the washer. Locate a 16mm A/F spanner onto the M16 Connector and unscrew. The Connector will remain connected to the end of the hose and is re-usable, if deemed to be in an acceptable condition.

2. Remove the rubber ball seal. Care must be taken when removing this as beneath the seal is a spring supporting the sealing ball. This ball may be ejected from the assembly resulting in loss or injury.

3. Remove the spring and the sealing ball and thoroughly clean the parts with a mild detergent and clean water. If the sealing ball, rubber seal or spring appear to be damaged or badly pitted, the parts should be replaced.

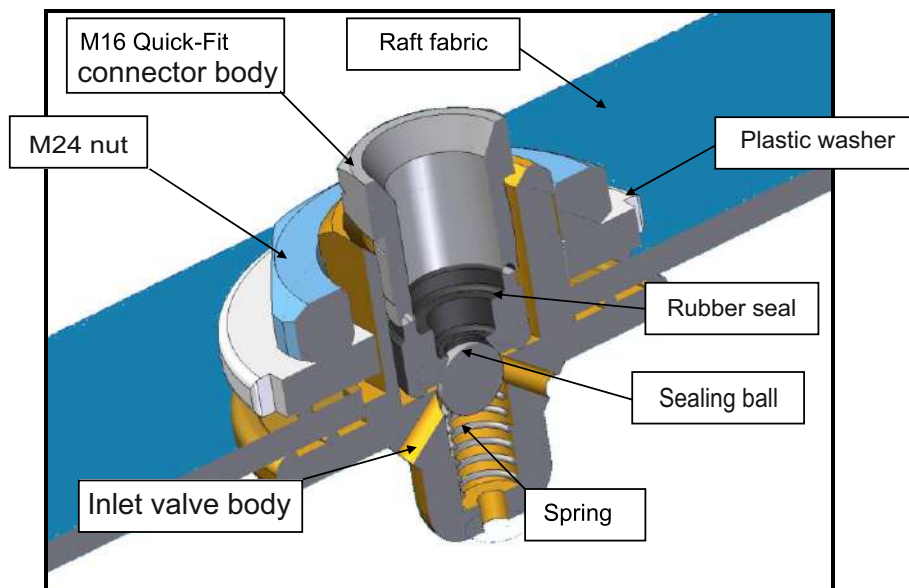

Section:	Remedial Actions and Repairs			 OCEAN SAFETY®
DATE:	31/10/2020	CREATED BY:	P.Marlow	
ISSUE:	02/2020	CHECKED BY	J.Beaumont	

M-07-IS-GIVT Revision 8

4. Thoroughly dry the components and lightly grease with Molykote 111.
5. Carefully put the spring in the valve body. Drop the sealing ball on top followed by the rubber seal. Important: Ensure that the seal is the right way up, tapered hole over the sealing ball, and push down square with the valve body.
6. Screw in the M16 Quick-Fit Connector Body and torque to a setting of 20Nm (15 ft/lb).
7. Operate the valve by pushing the 4mm rod, TM2238, through M16 Quick-Fit Connector Body and check that the metal ball moves freely against spring pressure.
8. Once the M16 Quick-Fit Connector Body and the Hose have been connected, the M16 Quick-Fit Connector Body becomes a permanent hose attachment.

3.2 If the valve is leaking from around the plastic washer and fabric:

This type of leakage occurs if the valve has become loose in the fabric. To identify this type of leak cover the area around the washer with soapy water and watch for bubbles. To rectify this type of leak, carry out the following procedure.

1. Locate the inlet valve spanner into the 4 locations on the outside diameter of the washer.
2. Locate a 33mm A/F spanner and torque wrench on the M24 nut. Rotate the spanner to align the jets in the inlet valve by ensuring the arrows on the spanner are orientated along the longitudinal axis of the tube. Tighten the M24 nut to torque 30Nm (22.1 ft/lbs).
3. Inflate the tube and check that the leak has stopped by applying some soapy water around the washer. If the valve is still leaking, bubbles will be visible and the washer should be replaced.

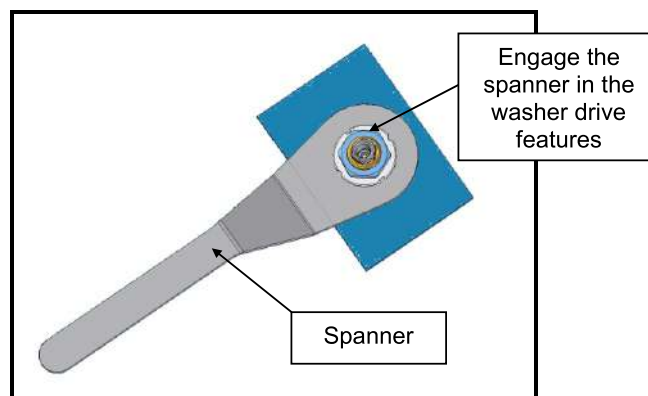

Section:	Remedial Actions and Repairs			
DATE:	31/10/2020	CREATED BY:	P.Marlow	
ISSUE:	02/2020	CHECKED BY	J.Beaumont	

M-07-UM-GIST Revision 14 ~ Section 5

5.5.3 ~ GIST Cylinder Valve Installation Extract from manufacture's manual

Warning: The following checks must be carried out prior to installation of cylinder valve to cylinder.

1. Ensure that the cylinder and Cylinder Valve threads are compatible and that the cylinder conforms to the standard specified for the working pressure on the Cylinder Valve. Ensure that the cylinder is approved for use in the applicable market.

2. Ensure that the Cylinder threads and interior are clean dry and free from unacceptable corrosion i.e. flaking or pitting.

3. Ensure that the Cylinder Valve threads show no visible sign of damage.

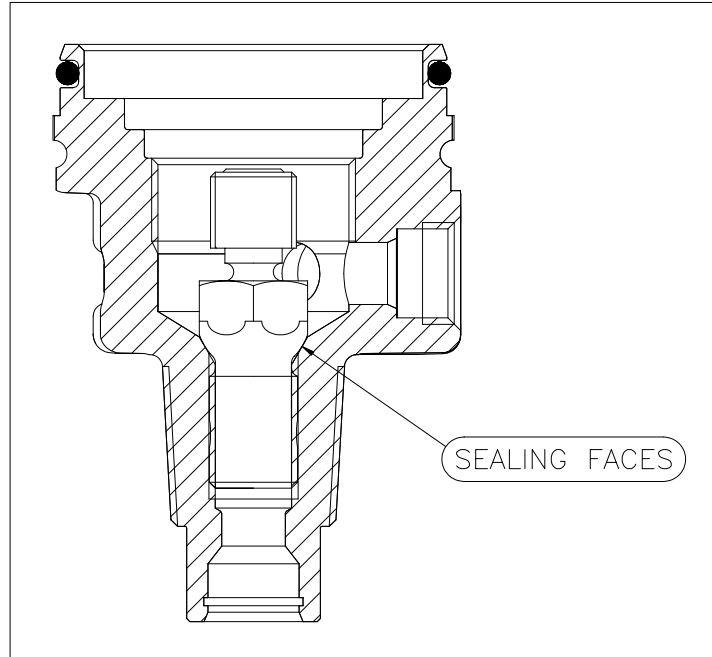

4. Ensure that the Syphon Tube (where fitted) is free to swivel and rotate.

5. Ensure that all Cylinder Valve Bores, recesses and sealing faces are clean and dry. Note that the Break Stem Seal Assembly may already be fitted to previously unused Cylinder Valves. If so, do not remove prior to filling.

6. Sealing material (PTFE Tape) should be applied to the threads as recommended by the Liferaft manufacturer or Leaffield Marine Ltd. No grease or oil should be used on the Cylinder Valve thread when fitting the Valve.

7. Tighten Cylinder Valve to a torque of 160-170Nm

Caution: If the valve is over tightened, the cylinder thread is incompatible or lubrication is applied to the thread, the valve body can distort & prevent the break stem sealing. This will often be indicated by the thread squeaking as the break stem is tightened.

Caution: Never insert any implement into the cylinder valve body that could damage the sealing face or break stem seal assembly.

Warning: Ensure the valve & cylinder is clean & dry before assembly.

Section:	Remedial Actions and Repairs			 OCEAN SAFETY®
DATE:	31/10/2020	CREATED BY:	P.Marlow	
ISSUE:	02/2020	CHECKED BY	J.Beaumont	

M-07-UM-GIST Revision 14 ~ Section 10

5.5.4 ~ GIST Operating Head, Resetting Procedure.

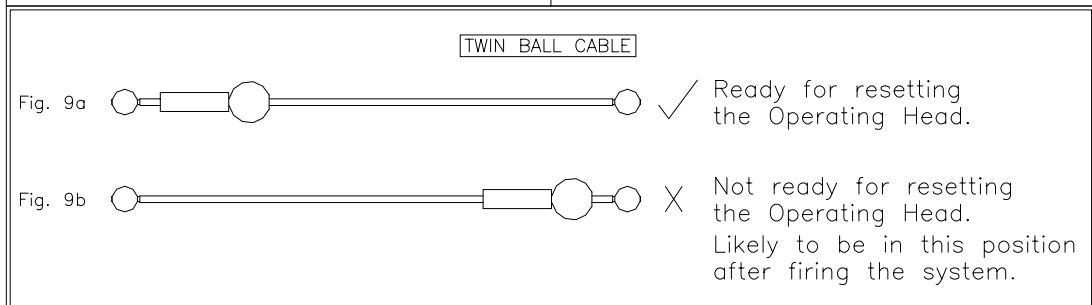
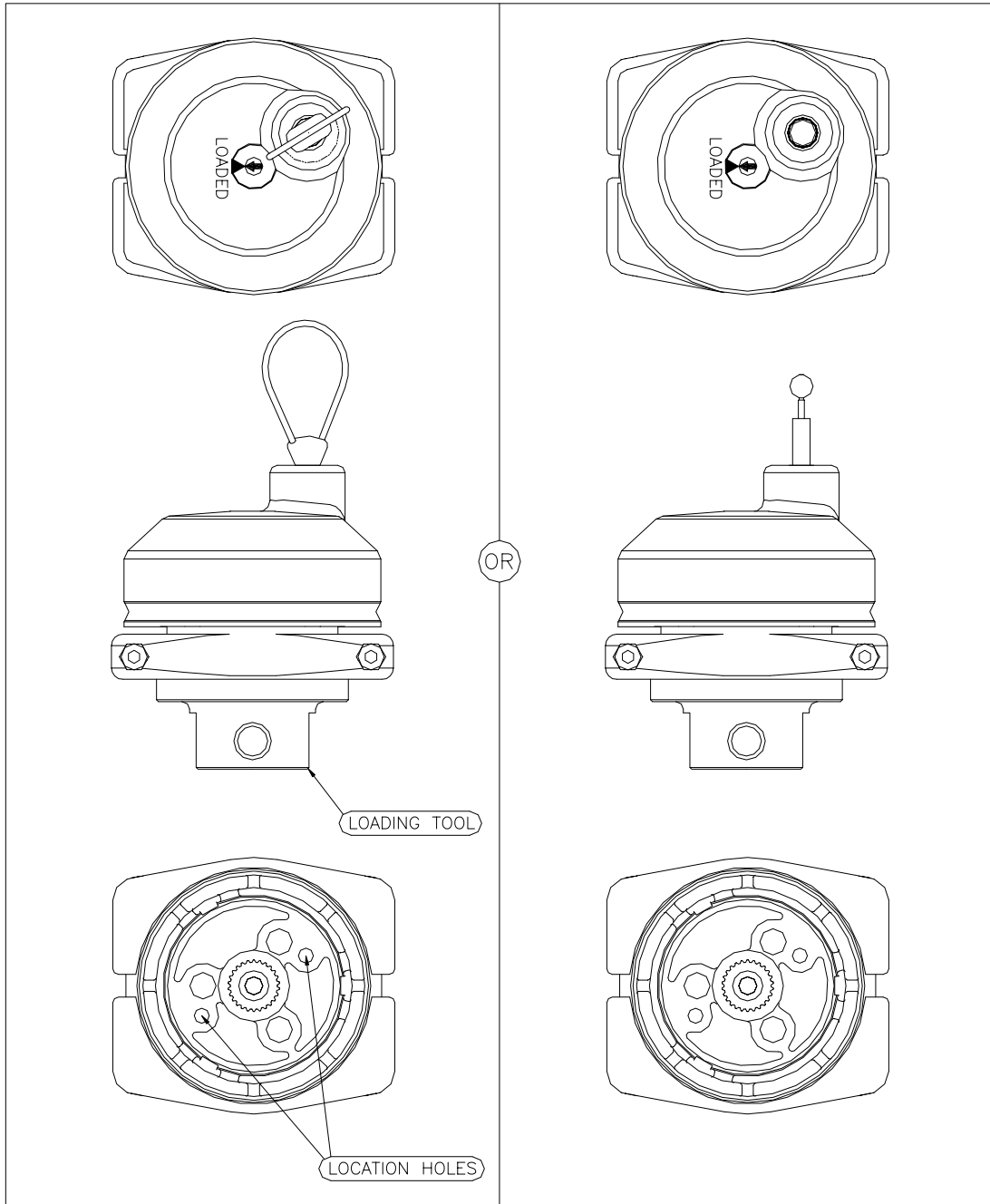

Section:	Remedial Actions and Repairs			
DATE:	31/10/2020	CREATED BY:	P.Marlow	
ISSUE:	02/2020	CHECKED BY	J.Beaumont	

M-07-UM-GIST Revision 14 ~ Section 10

GIST Operating Head, Resetting Procedure.

1. Remove the clamp screws retaining the operating head to the cylinder valve.
2. Remove the operating head from the cylinder valve.
3. Examine the operating head. Discard if damaged or more than 15 years old. Discard if the operating head is black and the cylinder is to be re-filled.
4. An operating head previously used in a deployment in water **MUST** be flushed through with clean water and dried thoroughly in air.

Warning: The operating head is intended as a sealed for life unit and must not be disassembled. It must not be cleaned with solvents, soaps or chemical agents. These may degrade the system components and cause a malfunction.

5. Check the firing wire assembly for the condition of sealing ball. Discard if damaged.

The white operating head must be fitted with a twin ball firing wire with a black seal.

Warning: If the sealing ball shows any signs of surface damage or deformation the entire wire must be discharged and replaced, or water may enter the system and cause a malfunction.

6. Apply a smear of Molykote 111 grease to firing wire port in the operating head and to the rubber seal of the firing wire assembly.
7. Locate the resetting tool in a vice, pins upwards.
8. Locate the two pins into the blind holes on the underside of the operating head. Grip the outside of the operating head. Turn the operating head fully anti-clockwise to expose the circular recess for the metal ball, which can be seen through the wire port in the casing.
9. Push the metal ball of the firing wire into the cable port. Rotate the loading tool clockwise to wind the firing wire into the casing. Then push the sealing ball into place in the port. Continue turning until a click is heard and felt. The Operating Head is now re-set.
10. The loaded indicator arrow on top of the casing will line up to indicate the unit is loaded.

Warning: The operating head must be clicked into the fully loaded position to function. If there is no click to indicate that the operating head is loaded, turn anti-clockwise, remove the cable and reload as above. If there is no click for a second time, discard the operating head and firing wire and replace with new.

Section:	Remedial Actions and Repairs			 OCEAN SAFETY®
DATE:	31/10/2020	CREATED BY:	P.Marlow	
ISSUE:	02/2020	CHECKED BY	J.Beaumont	

M-07-UM-GIST Revision 14 ~ Section 11

5.5.5 ~ Refurbishment of Cylinder Valve after Firing

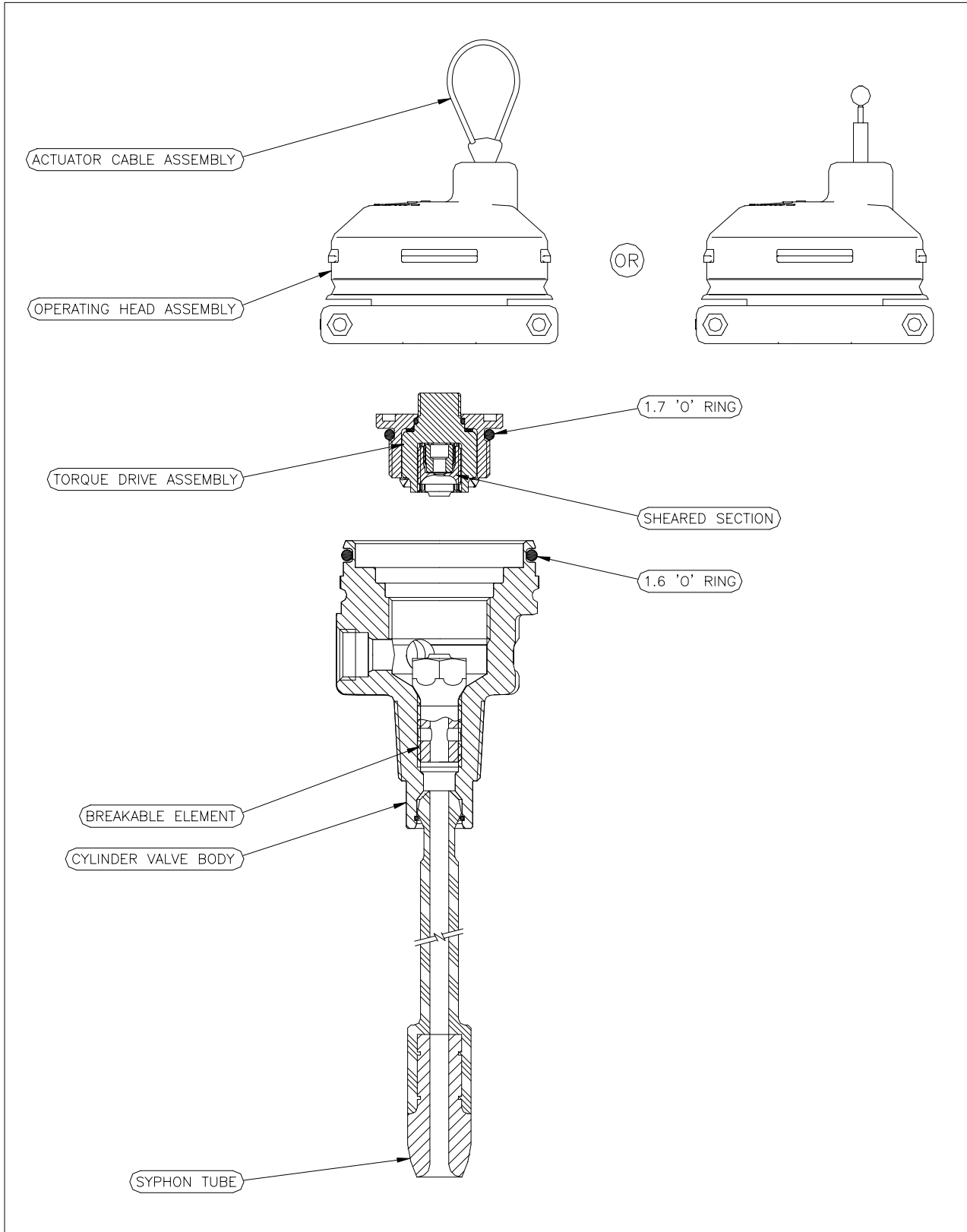

Section:	Remedial Actions and Repairs			
DATE:	31/10/2020	CREATED BY:	P.Marlow	
ISSUE:	02/2020	CHECKED BY	J.Beaumont	

M-07-UM-GIST Revision 14 ~ Section 11

Refurbishment of Cylinder Valve after Firing

1. Check the exterior of Cylinder Valve. Significant areas of pitting are not acceptable.
2. Remove 'O' Ring Flange Seal from Cylinder Valve and discard.
3. Thoroughly clean and dry the Cylinder Valve Body, ensuring no cleaning solution can enter the cylinder.

Warning: Cylinder valve must not be cleaned with solvents, soaps or chemical cleaning agents. These may degrade system components & cause malfunction.

Warning: Cylinder valves must not be reused if there is any significant distortion, corrosion or impact damage or if there is damage to external threads, hose seating surface or break stem seal seating surface .

4. Remove Torque Drive Assembly using the Loading Tool.
5. Replace the 'O' Ring. Lightly grease and fit new 'O' Ring. Use only Dow Corning Molykote 111 silicone grease.
6. After a normal operation it is usual for a broken part of the Break Stem Seal to be retained in the torque coupling. The broken part must be removed. This is best done using a pair of long-nosed pliers.
7. Remove the broken part of the Break Stem Seal Assembly from the Cylinder Valve using a long-series 17mm socket.
8. Fit Torque Drive Assembly, to act as a protective cap until the cylinder is ready to be refilled.
9. Lightly grease and fit new 'O' Ring Flange seal on Cylinder Valve. Use only Dow Corning Molykote 111 silicone grease.
10. Cylinder/Cylinder Valve is now ready for filling in accordance with procedures in Section 6.

Warning: Transit plugs & torque drive assembly must always be fitted to cylinder valve when charged cylinder is stored unconnected to liferaft.

Section:	Remedial Actions and Repairs			 OCEAN SAFETY®
DATE:	31/10/2020	CREATED BY:	P.Marlow	
ISSUE:	02/2020	CHECKED BY	J.Beaumont	

M-07-UM-GIST Revision 14 ~ Section 6

5.5.6 ~ Cylinder Charging Procedure

1. Before fitting, check that the plastic parts of the torque drive assembly rotate smoothly within the brass housing. If they do not, discard and replace with a new assembly.
2. Screw torque drive assembly fully into the cylinder valve body using the “Operating Head Resetting Tool”. Hand tight or torque setting 4Nm (2.95ft/lb) is sufficient.

Warning: Where the cylinder capacity exceeds 20 litres water volume, fit guard ring during transit and handling; unless the cylinders are transported and handled in cassettes.

Warning: Torque drive assembly must be fitted to cylinder valve when charged cylinder is to be handled, transported or stored.

CAUTION: Do Not store charged cylinder in direct sunlight or where temperature can exceed 65°C.

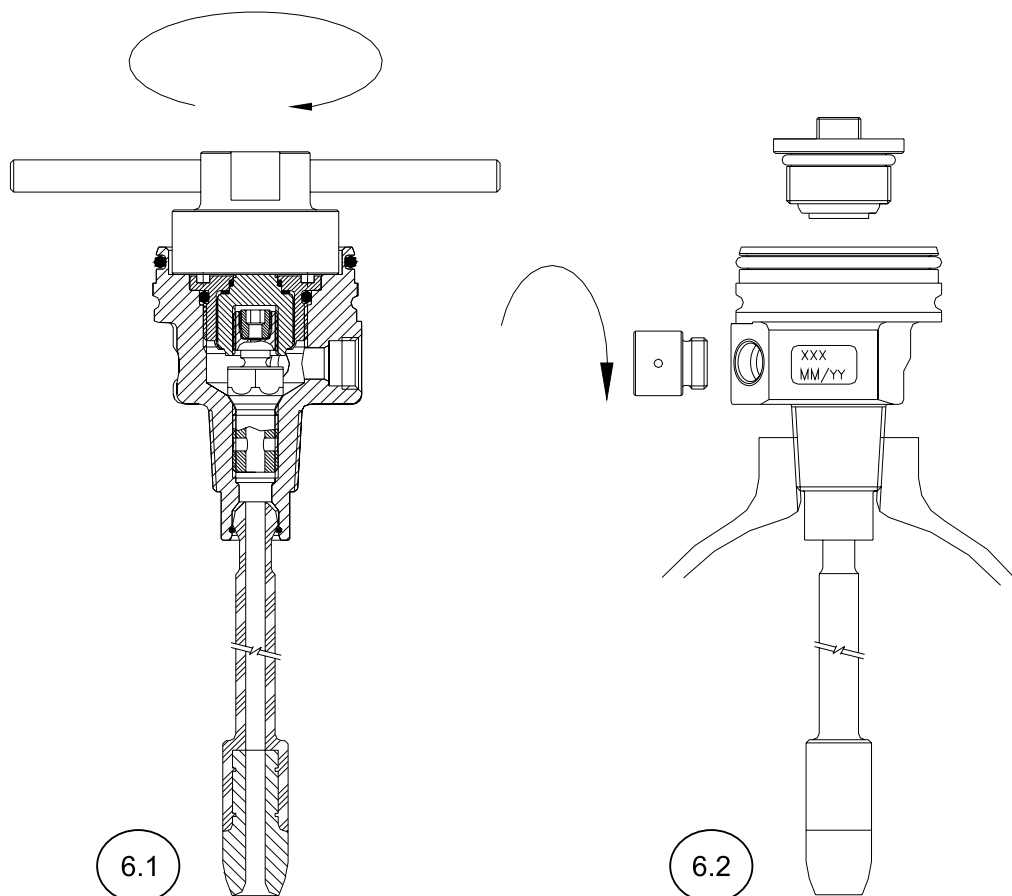

Section:	Remedial Actions and Repairs			 OCEAN SAFETY®
DATE:	31/10/2020	CREATED BY:	P.Marlow	
ISSUE:	02/2020	CHECKED BY	J.Beaumont	

5.5.7 ~ Top Up Valves

Top up valves may be replaced if fault is found with a valve or there are signs of damage to the valve. The Ocean Range of liferafts may be supplied (dependant on age) with either the Airflow top up valve or the A8 Top up valve. Pictures below illustrate the visual differences.



With both valves the workings are in the top section therefore there is no need to cut the tube to replace the valve. Use the appropriate service tool (Airflow valve) or socket (A8 valve) to remove the top section of the valve. Ensure the parts of the valve located on the inside of the tube are retained and not lost in the process. Once the upper part of the valve is removed all loose or damaged parts must be removed from the internal chamber of the bladder. If the internal threaded part is not damaged this may remain inside for the location of the new top part.

Locate the top section of the valve through the exposed hole and into the threaded base. Note the A8 also has an internal washer that must be installed between the internal nut and the fabric. There is a raised section on the washer that must face up towards the fabric Figure 1 below refers. The base requires securing without damaging the fabric of the liferaft. With the valve assembled apply the required torque load to the valve,

- Air Flow Valve 16Nm
- A8 Valve 16Nm

Figure 1 - A8 Top Up Valve

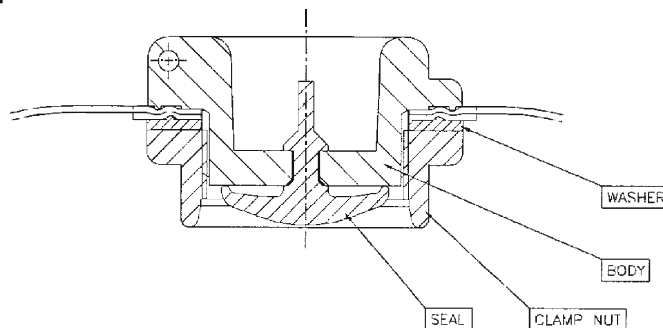

Locate the top section of the valve through the exposed hole and into the threaded base. The base requires securing without damaging the fabric of the liferaft. With the valve assembled apply a torque load of 16Nm to the top section of the valve using the appropriate tool.

Any replacement valves must be checked for air tightness before the valve is re-packed.

Section:	Remedial Actions and Repairs			 OCEAN SAFETY®
DATE:	31/10/2020	CREATED BY:	P.Marlow	
ISSUE:	02/2020	CHECKED BY	J.Beaumont	

5.6 ~ Ocean ISO UltraLite Components

5.6.2 ~ Cylinder Assembly

The cylinder valve has a twin outlet adaptor fitted to the main outlet. If this is found to be loose in service it will require re-bonding using semi permeate thread locker and Loctite 511. Thread locker shall be used to create the bond on the end threads of the cylinder valve, Loctite 511 shall be applied to the first 3 threads of the adaptor to prevent moisture entering the assembly. Fig 5.6 refers. Ensure the threads are cleaned before re-applying any compound.

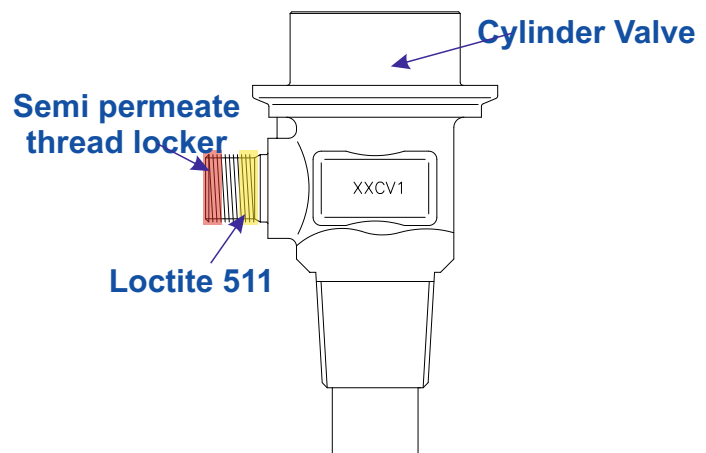
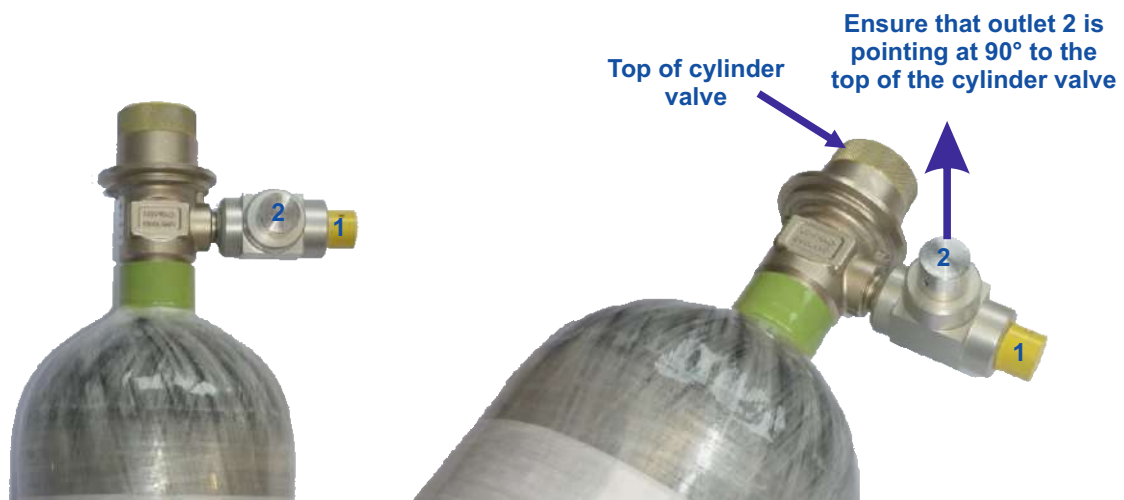



Figure 5.6 - Compound application

Apply the thread locking compound following the manufacturers instructions and reinstall the adaptor. Thread the adaptor and turn it right down to the bottom of the threads. Note that there are 2 outlets on the adaptor, one that runs parallel with the cylinder valve outlet and the other is at 90° to the outlet. Turn the adaptor back so that the outlet at 90° is in the orientation depicted in Fig 5.7.

Figure 5.7 - Twin Outlet Adaptor



Section:	Remedial Actions and Repairs			
DATE:	31/10/2020	CREATED BY:	P.Marlow	
ISSUE:	02/2020	CHECKED BY	J.Beaumont	

LEL-20018 Issue 7 ~ Section 5

5.6.2 ~ GIS Cylinder Valve Installation

Warning: The following checks must be carried out prior to installation of cylinder valve to cylinder.

1. Ensure that the cylinder & cylinder valve threads are compatible & that the cylinder conforms to the standard specified for the working pressure identified on the cylinder valve.
2. Ensure that the Cylinder Valve threads show no visible signs of damage.
3. Ensure that the Syphon Tube (where fitted) is free to swivel and rotate.
4. Ensure that all Cylinder Valve Bores and recesses are clean and free from particles.
5. Ensure that the Sealing Face and Anvil are free from damage and debris.

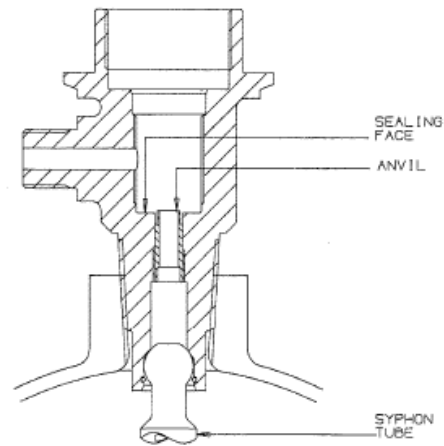

INSTALLATION

6. Sealing material should be applied to the threads as recommended by the LIFE RAFT manufacturer. Tighten Cylinder Valve to a torque of 160-170Nm

Caution: Never insert into the cylinder valve body any implement which could damage the sealing face or anvil.

Warning: Do not exceed the recommended torque or attempt to further tighten the cylinder valve once the gas bottle is charged as this could cause failure of the valve.

Section:	Remedial Actions and Repairs			
DATE:	31/10/2020	CREATED BY:	P.Marlow	
ISSUE:	02/2020	CHECKED BY	J.Beaumont	

LEL-2008 Issue 7 ~ Section 7

5.6.3 ~ Fitting Penetrator Assembly

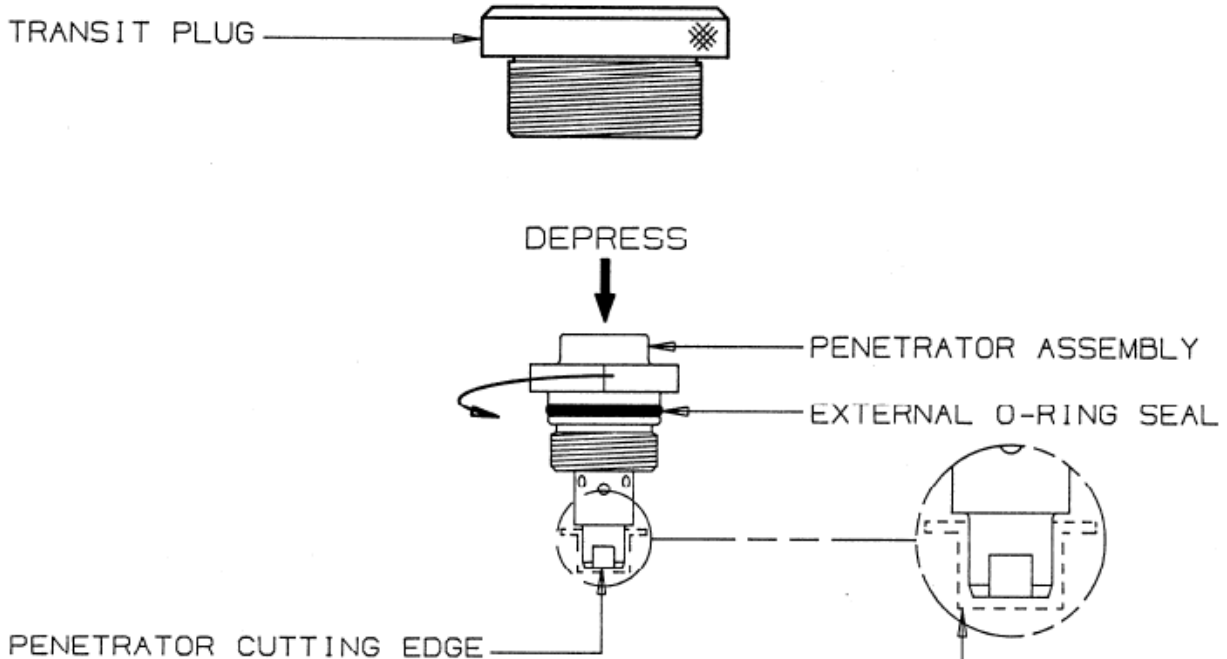

WARNING:
PROTECTIVE CAP MUST
BE REMOVED WHEN
PENETRATOR ASSEMBLY
IS FITTED.

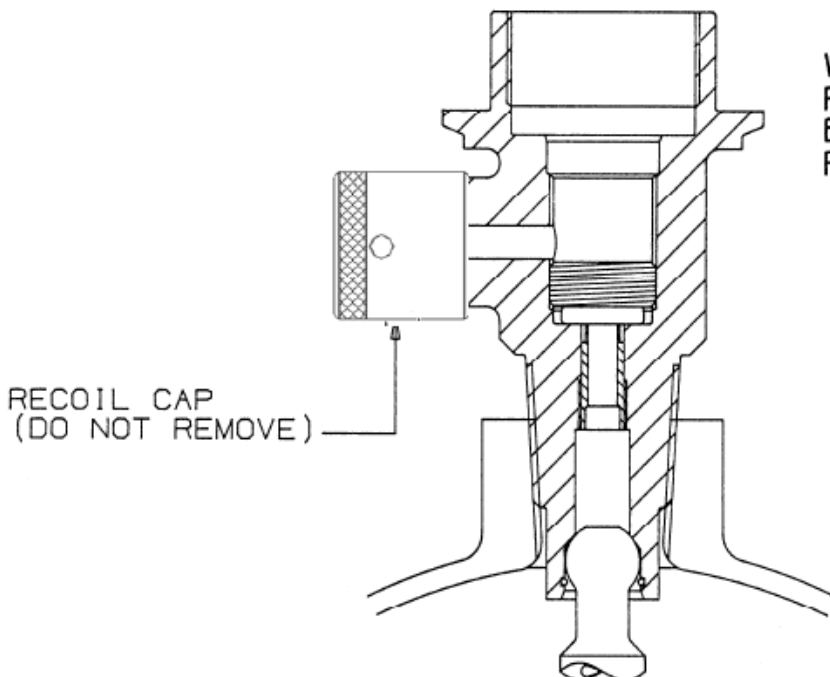

Section:	Remedial Actions and Repairs			
DATE:	31/10/2020	CREATED BY:	P.Marlow	
ISSUE:	02/2020	CHECKED BY	J.Beaumont	

LED-2008 Issue 7 ~ Section 7

Fitting Penetration Assembly

1. Remove Transit Plug from Cylinder Valve.

Warning: Do not remove recoil cap.

2. Remove protective cap from Penetrator Assembly.

3. Visually inspect penetrator blade to ensure there is no damage to cutting edge. Plug Gauge must freely enter and move in bore of penetrator.

Warning: If plug gauge does not enter penetrator or if penetrator shows signs of significant damage, penetrator assembly must be discarded & replaced.

4. Depress penetrator shaft to ensure freedom of movement.

5. Ensure external 'O' Ring is in good condition. Smear with a thin film of Molykote 111 grease.

6. Fit Penetrator Assembly into Cylinder Valve and tighten to a torque of 25Nm using suitable 24mm A/F spanner and torque wrench.

Warning: Never insert any implement into cylinder valve or push down penetrator shaft when penetrator assembly is fitted as this could cause violent gas discharge.

7. Re-fit Transit Plug.

Caution: Transit plug should be fitted to cylinder valve when charged cylinder is to be handled, transported or stored with penetrator fitted, to prevent ingress of dirt.

Caution: Do not store charged cylinders in direct sunlight or where temperatures can exceed 65°C.

Section:	Remedial Actions and Repairs			 OCEAN SAFETY®
DATE:	31/10/2020	CREATED BY:	P.Marlow	
ISSUE:	02/2020	CHECKED BY	J.Beaumont	

LEL-2008 Issue 7 ~ Section 8

5.6.4 ~ GIS Assembly of Operating Head to Cylinder Valve

1. If fitted, remove Transit Plug fro cylinder valve.

Warning: Do not remove recoil cap.

2. Apply a thin film of Molykote 111 grease to 'O' Ring flange seal & fit to neck of cylinder valve.

Warning: Ensure that 'O' Ring seal is correctly lubricated & fitted as this is a critical item to prevent ingress of water.

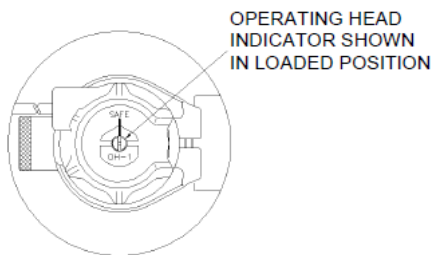
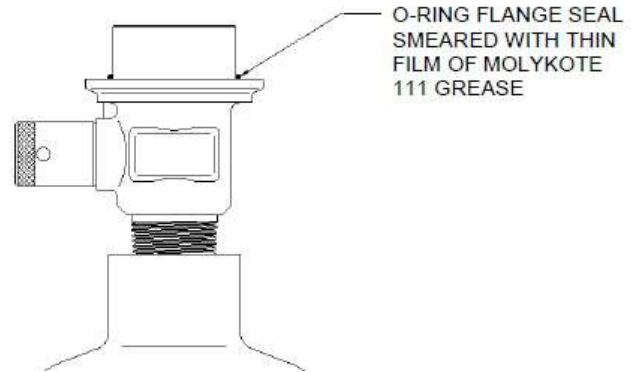

3. Check that the operating head is loaded. Screwdriver shot must be in line with SAFE marking as shown. If not, reload.

Warning: Operating head must be correctly loaded or system will not function.

4. Locate Operating Head onto Cylinder valve. Push fully home before proceeding to fit clamp.

5. Fit clamp & retain nut with a suitable Ø6mm rob until screw is initially engaged tightens using a Pozidriv No.2 screwdriver so the Operating Head can just be rotated by hand on Cylinder valve. Align Operating Head as required.

6. Tighten screw further until rotation of the operating Head is just prevented. Tighten a further one turn. **DO NOT OVER TIGHTEN.** This will leave a gap as shown in next diagram depending on the type of clamp fitted/

7. Clamp Type B: If the Operating Head is being reused, it is possible that the clamp has previously been over-tightened & stretched. In this case it is acceptable to tighten beyond the nominal gap shown in next diagram to ensure the operating Head cannot rotate on the cylinder Valve.

Section:	Remedial Actions and Repairs			 OCEAN SAFETY®
DATE:	31/10/2020	CREATED BY:	P.Marlow	
ISSUE:	02/2020	CHECKED BY	J.Beaumont	

LEL-2008 Issue 7 ~ Section 8

GIS Assembly of Operating Head to Cylinder Valve

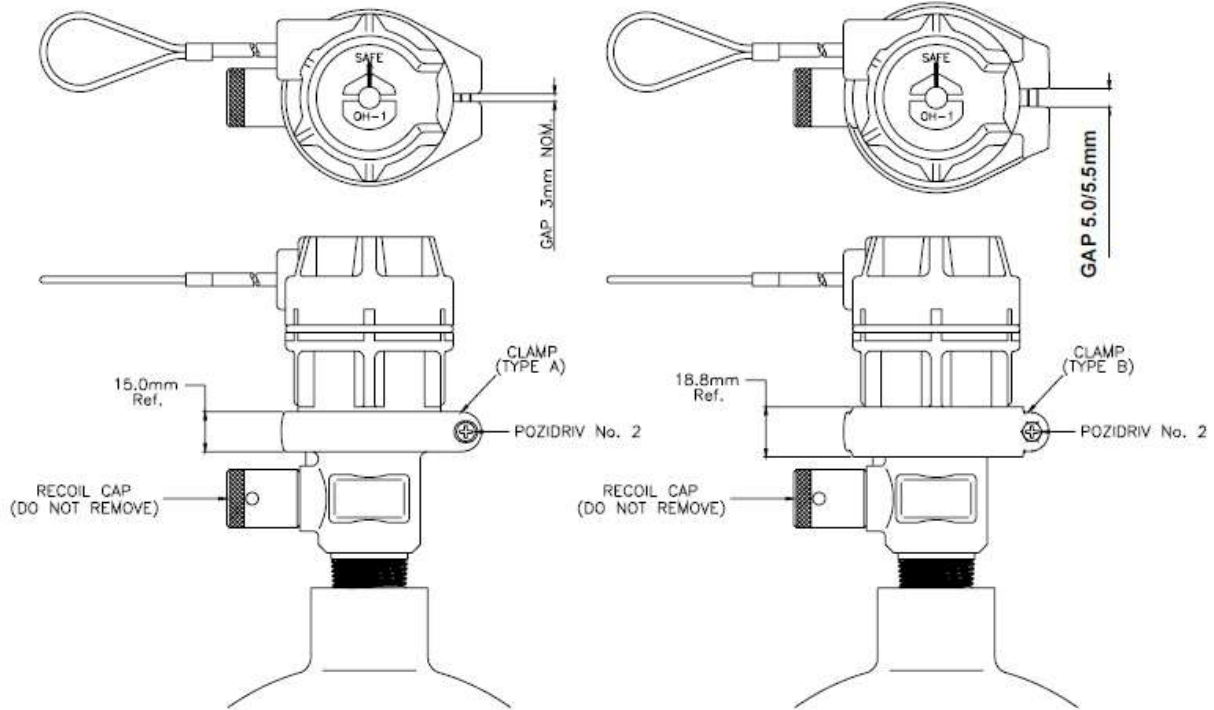

CAUTION: The clam faces will not meet when the screw is tightened. A gap will be evident, nominally as shown above. Do not over tighten screw.

CAUTION: Do not store charged cylinders in direct sunlight or where temperature can exceed 65°C.

Note: For GIS Valves on Ultralite liferafts in the new style containers the firing wire will be of the twin ball type.

Section:	Remedial Actions and Repairs			 OCEAN SAFETY®
DATE:	31/10/2020	CREATED BY:	P.Marlow	
ISSUE:	02/2020	CHECKED BY	J.Beaumont	

LEL-2008 Issue 7 ~ Section 12

5.6.5 ~ GIS Resetting of Operating Head after Firing
 Figure 12:

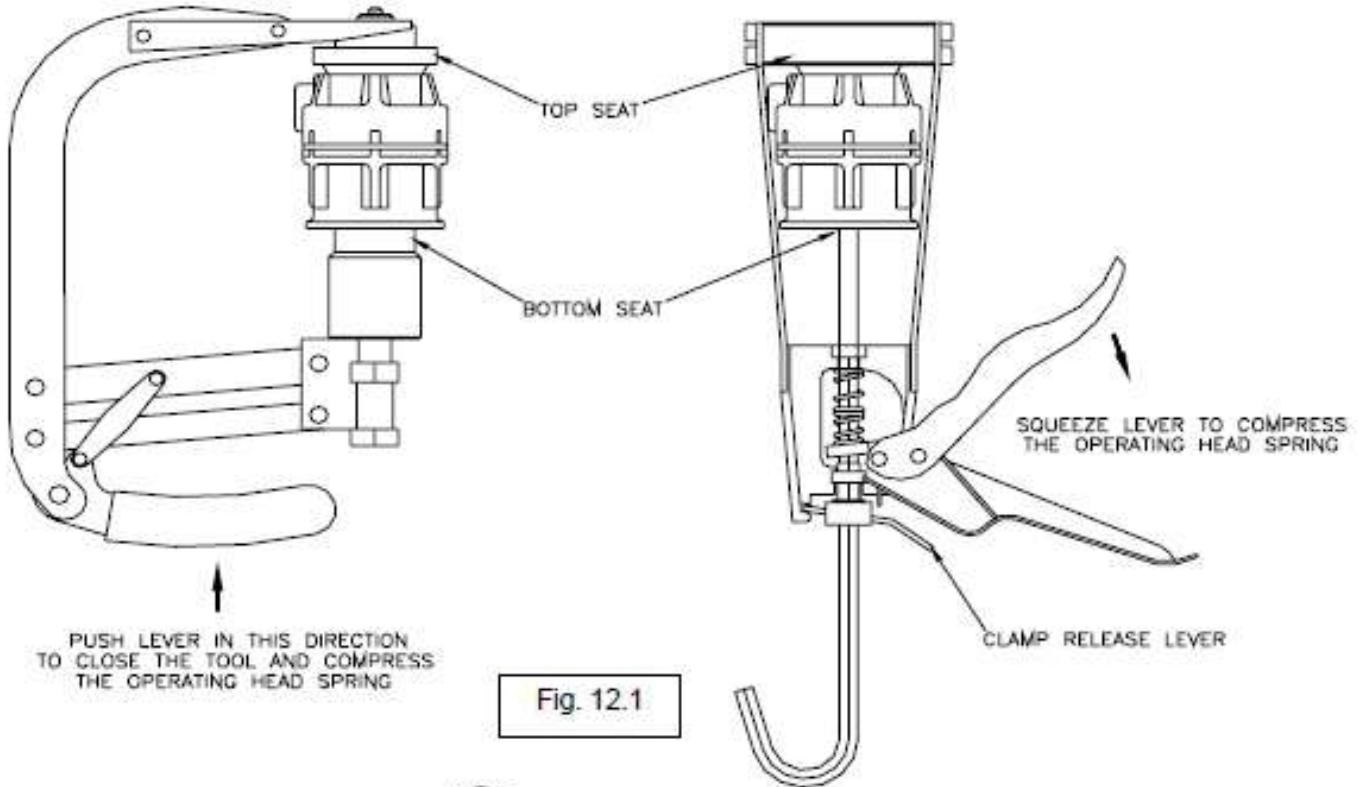

Fig. 12.1

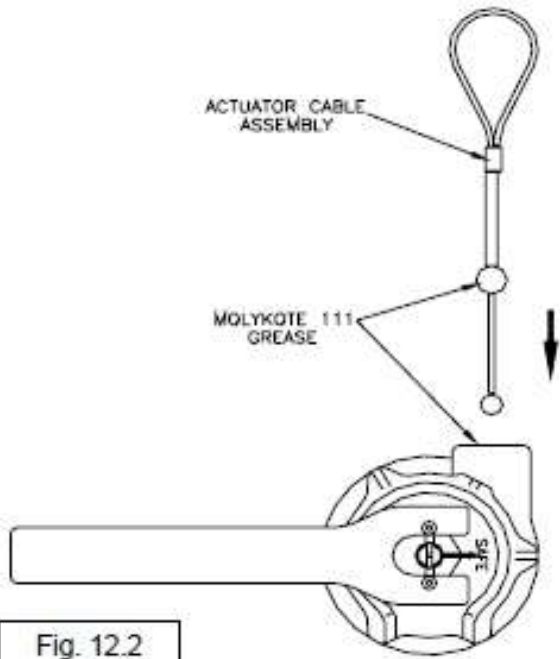

Fig. 12.2

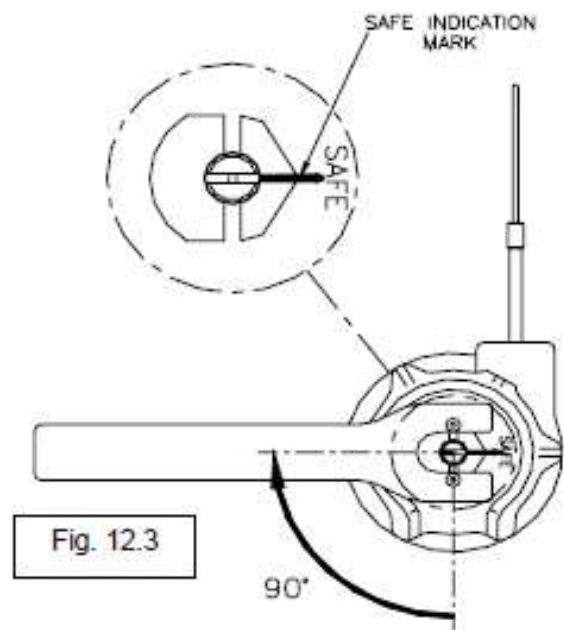



Fig. 12.3

Section:	Remedial Actions and Repairs			
DATE:	31/10/2020	CREATED BY:	P.Marlow	
ISSUE:	02/2020	CHECKED BY	J.Beaumont	

LEL-2008 Issue 7 ~ Section 12

GIS Resetting of Operating Head after Firing

1. Remove the clamp retaining Operating Head to Cylinder Valve. Remove Operating Head from Cylinder Valve.
2. Visually examine Operating Head. Discard if damaged or more than 15 years old.
3. An Operating Head previously used **MUST** be flushed through with clean water and dried thoroughly in air.

Note: WD40 can be applied to the Operating Head mechanism to prevent surface corrosion if used regularly in training.

WARNING: Operating Head must not be cleaned with solvents, soaps or chemical cleaning agents. These may degrade system components & cause malfunction.

4. Locate Operating Head into Top Seat of Loading Tool. (Fig. 12.2 refers)
5. Compress Operating Head spring by pushing Loading Tool lever fully home or squeezing handles 3-4 times (depending on Loading Tool used), ensuring that Bottom Seat enters fully into Operating Head. Take care not to scratch chamfered entrance of plastic body. (Fig. 12.2 refers)
6. Visually examine Actuator Cable Assembly for condition of crimp, ball end and sealing ball. Discard if damaged. (Fig. 12.2 refers)

WARNING: If sealing Ball shows any signs of surface damage or deformation the entire cable must be replaced, or water may enter the system & cause malfunction.

7. Apply a smear of Molykote 111 grease to cable port in Operating Head and to rubber ball seal of Actuator Cable Assembly. Push the rubber ball seal away from the metal ball end, up to the plastic sleeve. Insert Actuator Cable into cable port in Operating Head.

8. Using a suitable, parallel tip screwdriver turn screwdriver slot in top of Operating Head **CLOCKWISE** through 90° to pull in Actuator Cable and reset Operating Head. (Fig. 12.3 refers)

9. Unclamp Loading Tool and remove Operating Head.
10. Ensure the screwdriver slot is aligned with the SAFE mark.

WARNING: Operating Head must be correctly loaded or system will not function.

11. Fit Safety Pin, if required.
12. Store in a clean, dry place until required.

Section:	Remedial Actions and Repairs			 OCEAN SAFETY®
DATE:	31/10/2020	CREATED BY:	P.Marlow	
ISSUE:	02/2020	CHECKED BY	J.Beaumont	

LEL-2008 Issue 7 ~ Section 13

5.6.6 ~ GIS Refurbishment of Cylinder Valve after Firing

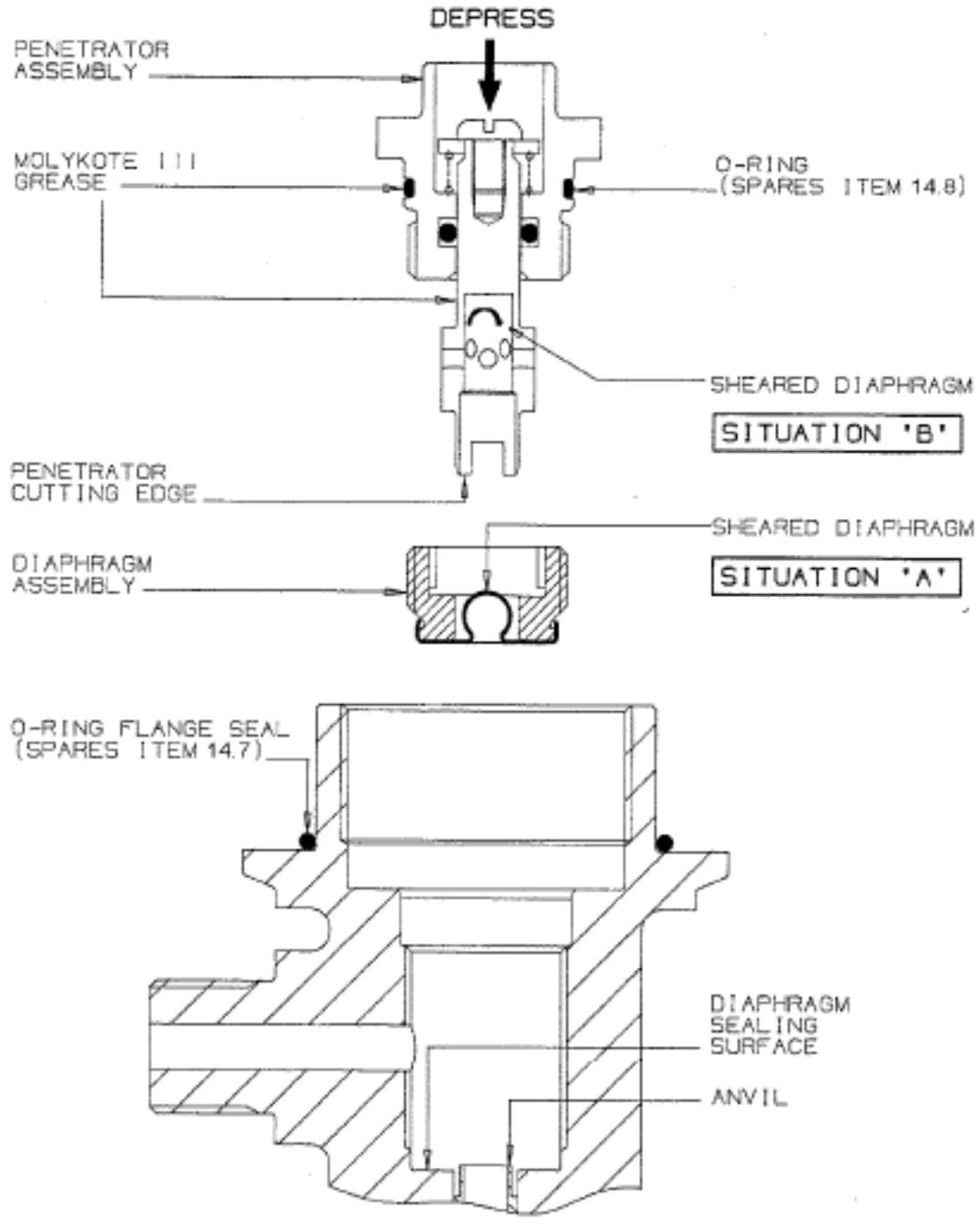

Section:	Remedial Actions and Repairs			
DATE:	31/10/2020	CREATED BY:	P.Marlow	
ISSUE:	02/2020	CHECKED BY	J.Beaumont	

LEL-2008 Issue 7 ~ Section 13

GIS Refurbishment of Cylinder Valve after Firing

1. Visually examine exterior of Cylinder Valve. Significant areas of exposed base metal (brass) or green corrosion are not acceptable.

2. Remove Penetrator Assembly, Diaphragm Assembly and 'O' Ring Flange Seal from Cylinder Valve. Discard 'O' Ring Flange Seal and external 'O' Ring on Penetrator Assembly, taking care not to damage the Penetrator Assembly 'O' Ring groove.

3. Thoroughly clean and degrease Cylinder Valve Body, ensuring no cleaning solution can enter the cylinder.

WARNING: Cylinder Valve must not be reused if there is any significant distortion, corrosion or impact damage or if there is damage to external threads, hose seating surface, diaphragm seating surface or anvil.

4. Establish if sheared diaphragm is Situation 'A' or Situation 'B'. In either situation the Diaphragm Assembly MUST be discarded. After a normal operation it is usual for the sheared diaphragm to be retained as shown in Situation 'A'. However, sometimes the cut element of the diaphragm may be lodged within the Penetrator as shown in Situation 'B'.(Fig.13.1 refers)

CAUTION: The Penetrator assemble may be reused if it has no more then 5 firings & is less than 15 years old. Otherwise it must de discarded & replaced with new.

5. If the Penetrator Assembly is to be reused, then the following actions MUST be carried out:

5.1 The sheared diaphragm, if in Situation 'B', must be carefully removed. This is best done using a pair of fine-nosed tweezers, with care being taken not to damage the cutting edge of the penetrator.

5.2 Clean Penetrator Assembly in clean water and dry thoroughly in air.

WARNING: Penetrator assembly must not be cleaned with solvents, soaps or chemical cleaning agents as this can degrade the components. Do not attempt to dismantle Penetrator assembly - This item is not serviceable,

5.3 Visually inspect penetrator blade to ensure there is no damage to the cutting edge. Plug Gauge must freely enter and move in the bore of the penetrator.

5.4 Depress penetrator shaft (in direction of arrow in fig. 13.1) to ensure freedom of movement and apply a thin film of Molykote 111 as shown.

5.5 Replace 'O' Ring with NEW Smear with a thin film of Molykote 111 grease and fit as shown, taking care not to damage 'O' Ring.

WARNING: If plug gauge does not enter Penetrator or if Penetrator shows signs of significant damage, penetrator assembly must be discarded & replaced with new.

Section:	Remedial Actions and Repairs			
DATE:	31/10/2020	CREATED BY:	P.Marlow	
ISSUE:	02/2020	CHECKED BY	J.Beaumont	

LEL-2008 Issue 7 ~ Section 13

GIS Refurbishment of Cylinder Valve after Firing.

6. Fit NEW Diaphragm Assembly and charge the cylinder..

7. Fit Penetrator Assembly.

8. Cylinder/Cylinder Valve is now ready for fitting of Operating Head and installation to liferaft

9. Fit a new 'O' Ring flange seal to Cylinder Valve body.

WARNING: Recoil cap must always be fitted to Cylinder Valve outlet when charged cylinder is stored unconnected to liferaft.

CAUTION: Transit plug should be fitted to cylinder valve when charged cylinder is to be handled, transported or stored with Penetrator Assembly fitted.

CAUTION: Do not store charged cylinder in direct sunlight or where temperature can exceed 65°C.

Section:	Remedial Actions and Repairs			
DATE:	31/10/2020	CREATED BY:	P.Marlow	
ISSUE:	02/2020	CHECKED BY	J.Beaumont	

5.7 ~ Ancillary Equipment

5.7.1 ~ Drogue & Line

If there is damage to the line of the sea anchor the entire length shall be replaced. The line is supplied cut to length direct from Ocean Safety. The line is sourced to comply with ISO 9650:1 2005. Only Ocean Safety parts may be assembled to the liferaft.

When connecting the line to the drogue, the line must be spliced on the webbing of the drogue. Do not use knots to fasten the line to the drogue.

If damage is present on mesh or the webbings of the drogue, the whole unit shall be replaced.

5.7.2 ~ Safety Knife / Whistle

Check the blade for signs of surface rust may be cleaned using abrasive paper. Anything more than surface rust will deem the part unfit for purpose and will require replacement.

Check that the whistle operates correctly & it is secured with a lanyard.

Any units showing signs of damage are to be replaced with Ocean Safety supplied spares.



5.6.3 ~ Quiot & Line

Check that the line is attached to the raft & that it is neatly coiled up with the quiot are secured within the pouch provided.



Section:	Remedial Actions and Repairs			
DATE:	31/10/2020	CREATED BY:	P.Marlow	
ISSUE:	02/2020	CHECKED BY	J.Beaumont	

5.6.4 ~ Containers fitted with Guides

Both the Mk2 Containers & Ultralite Containers have guides fitted.

The container is fitted with four guides on the lower section of the container. If one or more are damaged or missing they must be replaced before re-packing may commence.

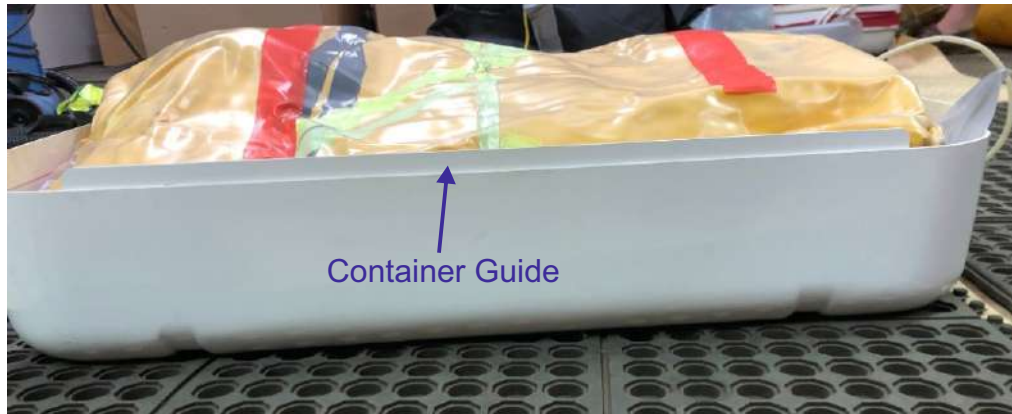

To replace the guides the bonding area must be dry and clean of all debris. Any broken guides are to be removed along with all adhesive residues. Clean the surface using solvent such as acetone - **Ensure protective equipment is worn while working with solvents or power tools.**

All surfaces for bonding require a key and cleaning with solvent before adhesive is applied. Re-bond the guides a high strength fast curing two part epoxy adhesive. Do not let the guides slip during curing time. Take care not to apply excessive adhesive at the containers mating edge. Follow the specific instructions for the adhesive use noting the cure times, required cavity depth and working time.

Section:	Remedial Actions and Repairs			 OCEAN SAFETY®
DATE:	31/10/2020	CREATED BY:	P.Marlow	
ISSUE:	02/2020	CHECKED BY	J.Beaumont	

5.8 ~ Torque Setting

The following are the various torque setting for the Ocean ISO Liferaft range.

Componet	Newton Meters	Feet Pounds
M24 Nut	30.0Nm	(22.1 ft.lb)
Fitting Hose to Cylinder Valve	12.2Nm	9.00 ft.lb
GIST Op. Head Bolts	1.12Nm	0.83 ft.lb
B10 PRV (initial setting	25.0Nm	18.44 ft.lb
B10 PRV (After 12 Hours)	29.0Nm	21.39 ft.lb
A8 Top-up Valve	16.0Nm	21.39 ft.lb
M16 Quick-Fit Connector Body	20.0Nm	15.00 ft.lb
M16 Nut Inlet Valve	9-12Nm	6.64-8.85 ft.lb
Torque Drive Assembly	4.0Nm	2.95 ft.lb
Cylinder Valve	160-170Nm	119-125 ft.lb
Break Stem Assembly	40.0Nm	29.5 ft.lb
GIS Diaphragm Assembly	35-40Nm	25.81-29.50 ft.lb
GIS Penetrator Assembly	25.0Nm	18.44 ft.lb

Section:	Liferaft Assembly & Packing			
DATE:	31/10/2020	CREATED BY:	P.Marlow	
ISSUE:	02/2020	CHECKED BY	J.Beaumont	

Section ~ 6

Pre-Assembly

Ocean ISO / Ocean ISO Ultralite Liferafts

Including the Mk2 Container

Section:	Liferaft Assembly & Packing			
DATE:	31/10/2020	CREATED BY:	P.Marlow	
ISSUE:	02/2020	CHECKED BY	J.Beaumont	

Section 6 ~ Liferaft Assembly and Packing

All modifications to the following sections shall be recorded in the table provided below. Once a new section is issued, replace the old version of the manual and destroy the obsolete pages.

Revision N°	Sections Affected	Issue Date	Inserted Date	Signature
Rev 0109	6.1, 6.5.1, appendix 1 to 4	02.06.09		C.Perks
Rev 1010	6.6 incorporated	07.10.10		C.Perks
Rev 0414	6.1,	30.04.14		J.Beaumont
02/2020	Complete update including the Mk2 container & the relevant enhancements	31/10/2020	31/10/2020	P.Marlow

Section:	Liferaft Assembly & Packing			
DATE:	31/10/2020	CREATED BY:	P.Marlow	
ISSUE:	02/2020	CHECKED BY	J.Beaumont	

6 ~ Assembly and Packing

6.1~ Emergency Packs

- 6.1.1 ~ ISO Pack 2, Less than 24 Hours
- 6.1.2 ~ ISO Pack1, Greater than 24 Hours
- 6.1.3 ~ SOLAS B Pack
- 6.1.4 ~ Clear Film Equipment Bag - Sealing Procedure.

6.2 ~ Deflation Process

6.3 ~ Equipment Fitted Before Packing

- 6.3.1 ~ Fitting the RL 6 Liferaft Light
- 6.3.2 ~ Fitting the AquaSpec Liferaft Light
- 6.3.3 ~ Attaching the Drogue
- 6.3.4 ~ Fitting the Cylinder
- 6.3.5 ~ Fitting the Operating Head
- 6.3.6 ~ Fitting of Ultralite Cylinder & Operating Head
- 6.3.7 ~ Securing the Emergency Pack

6.4 ~ Painter

- 6.4.1 ~ Attaching Painter Firing Lines Mk2
- 6.4.2 ~ Packing Painter Pocket

Section:	Liferaft Assembly & Packing			
DATE:	31/10/2020	CREATED BY:	P.Marlow	
ISSUE:	02/2020	CHECKED BY	J.Beaumont	

6.1 ~ Emergency Packs

To comply with the requirements of ISO 9650 each liferaft shall contain an emergency pack containing as a minimum the specified equipment as per the standard.

The Ocean ISO Liferaft range optional pack variants. Refer to section 2 for details of each pack content. The following section describes and depicts the packing procedure for each emergency equipment pack type within the Ocean ISO Liferaft range.

The equipment bag should be of the clear film type, in earlier Ocean ISO liferafts they may have the yellow fabric bag, this should be replaced.

6.1.1 ~ ISO Pack 2, less than 24 hour

Assemble the equipment for the ISO Pack 2 as per section 2 of this manual. Arrange the equipment as detailed in the pictures below.



Pack the equipment into the vacuum bag a stage at a time ensuring that all components are kept as flat and tidy as possible. Try to avoid packing solid components onto of one another.

Note: Pictures still show water, this is no longer supplied in the ISO Pack 2, less than 24 hour with Mk2 containers. However it may still be supplied in older models.

Section:	Liferaft Assembly & Packing			
DATE:	31/10/2020	CREATED BY:	P.Marlow	
ISSUE:	02/2020	CHECKED BY	J.Beaumont	

6.1.2 ~ ISO Pack 1, greater than 24 hour pack

Assemble the equipment for the ISO Pack 1 as per section 2 of this manual. Arrange the equipment as detailed in the pictures.

Pack the equipment into the vacuum bag a stage at a time ensuring that all components are kept as flat and tidy as possible. try to avoid packing solid components onto of one another.

Pictures below detailed the appearance of the assembled pack.



Section:	Liferaft Assembly & Packing			
DATE:	31/10/2020	CREATED BY:	P.Marlow	
ISSUE:	02/2020	CHECKED BY	J.Beaumont	

6.1.3 ~ SOLAS B pack

Assemble the equipment for the SOLAS B pack as per section 2 of this manual. Arrange the equipment as detailed in the pictures.

Pack the equipment into the vacuum bag a stage at a time ensuring that all components are kept as flat and tidy as possible. try to avoid packing solid components onto of one another.

Pictures below detailed the appearance of the assembled pack.

Note: the picture still show water as older rafts are still supplied. Liferafts with the Mk2 container are no longer supplied with water

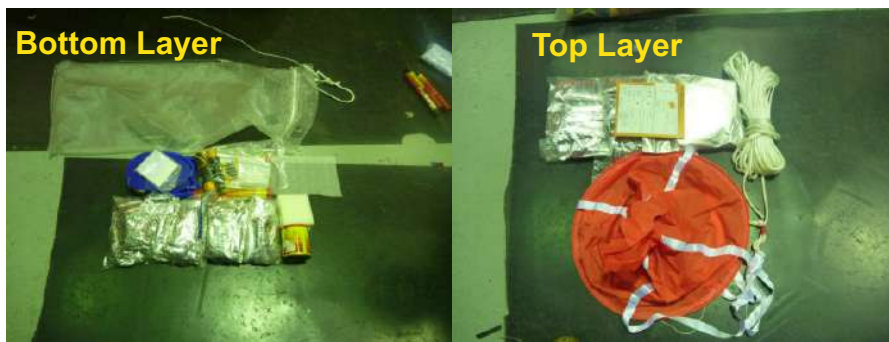

Section:	Liferaft Assembly & Packing			
DATE:	31/10/2020	CREATED BY:	P.Marlow	
ISSUE:	02/2020	CHECKED BY	J.Beaumont	

6.1.4 ~ Clear Film Equipment Bag - Sealing Procedure.

Using a high frequency hand held electrode, weld the upper and lower layers of the bag together. With the bag sealed use a vacuum pump via the integral valve, remove excess air within the equipment bag.



Section:	Liferaft Assembly & Packing			
DATE:	31/10/2020	CREATED BY:	P.Marlow	
ISSUE:	02/2020	CHECKED BY	J.Beaumont	

6.2 ~ Deflation Procedure

Before the liferaft may be packed the inflated structure requires deflation to aid packing. When deflating the structure use dry clean air and a vacuum pump or similar device to extract all excess gas within the liferafts buoyancy tubes.



Using a vacuum pump or similar device deflate the top tube through the top-up valve.

Once the tube has deflated re-install the top-up valve cap.

Ensure that the arch tube holds pressure throughout this process. If the arch deflates refer to the remedial action section for instructions.

Using a vacuum pump or similar device deflate the bottom tube through the top-up valve.

Once the tube has deflated re-install the top-up valve cap.

While the liferaft is deflating ensure that the folds of fabric are laying in a uniform manner.



Using a vacuum pump or similar device deflate the Arch tube through the top-up valve.

Once the tube has deflated re-install the top up valve cap.

While the liferaft is deflating ensure that the folds of fabric are laying in a uniform manner.

Section:	Liferaft Assembly & Packing			
DATE:	31/10/2020	CREATED BY:	P.Marlow	
ISSUE:	02/2020	CHECKED BY	J.Beaumont	

6.3 ~ Equipment Fitting before Packing

6.6 ~ Fitting the RL6 Light

Check that the light is working.

Make sure the battery is in date, the expiry date needs to be a longer date than the next service.

If the light is not working then first of all change the battery. If the light still doesn't work, then it will need to be changed.

Unplug light from the back of the battery. release the wire it can be threaded through the canopy patch, then pull the wire from outside through the pouch pocket. The light itself is held in by a hook & loop patch. Unfasten hook & loop & remove old light.

Replacing the light, place the light in to the holding patch & re-fasten the hook & loop in position. Feed the lead from the light to the canopy pouch and feed the lead in through the patch. Inside the raft reconnect the lead to the battery connector on the back of the battery, make sure its clipped into position.

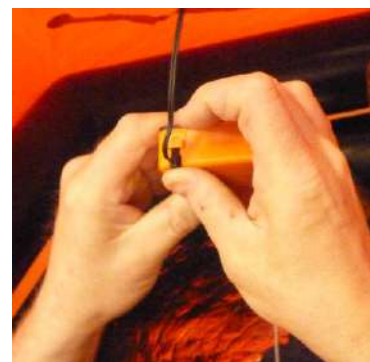

Using the hook & loop patches on the liferaft arch to secure the battery. Once in position tuck the light lead between the canopy and the arch.



There should be a cord that is secure to the black loop that is attached to the battery. The black loop is the part of the arming system, which activates the light. The cord will need to be attached to the safety line once the raft is deflated.

Section:	Liferaft Assembly & Packing			
DATE:	31/10/2020	CREATED BY:	P.Marlow	
ISSUE:	02/2020	CHECKED BY	J.Beaumont	

6.3.2 ~ Fitting the AquaSpec Liferaft Light

The new AquaSpec light has been introduced into all the Ocean Safety liferaft range from September 2020. This is replacing the RL 5 / RL 6 liferaft light.

It consists of an external light with lead & plug & Battery pack with integrated internal light with the plug connector for external light.



To fit the external light, first of all feed the lead through the hole under the light fitting patch. The external light has a securing ring the screw on/off, remove ring before fitting in to light holder then refit securing ring once external light in position.

Fitting the battery pack / internal light, on the arch there is a fitting patch with velcro strips. Using the Velcro strips secure the back plate of the battery/internal light, then clip the battery pack into place. Then connect the lead from the external light to the battery pack.



An activation line will need to be added to the yellow ring which is attached to the cord leading from the battery, this will need to be attached to a strong point once the raft has been deflated.

For old liferafts a service patch will be required.



AquaSpec Service Patch ~ (OSS0073), either glue the patch immediately to the left (as you look at the raft) of the current patch with the tie cords or, cut the tie cords off and glue the patch over the existing patch.

Use Bostik 2402, Apollo 486 or local equivalent, follow the manufacturers instructions and allowed to fully cure. It is not necessary to pressure test after the cure period on this patch.

Section:	Liferaft Assembly & Packing			
DATE:	31/10/2020	CREATED BY:	P.Marlow	
ISSUE:	02/2020	CHECKED BY	J.Beaumont	

6.3.3 ~ Attachment of Drogue



1) Take the tail end of the drogue line. Run the drogue line around the left hand side of the liferaft leaving the drogue in the front entrance of the liferaft.



2) Take the end of the drogue line and thread it through the eyelet in the drogue patch.

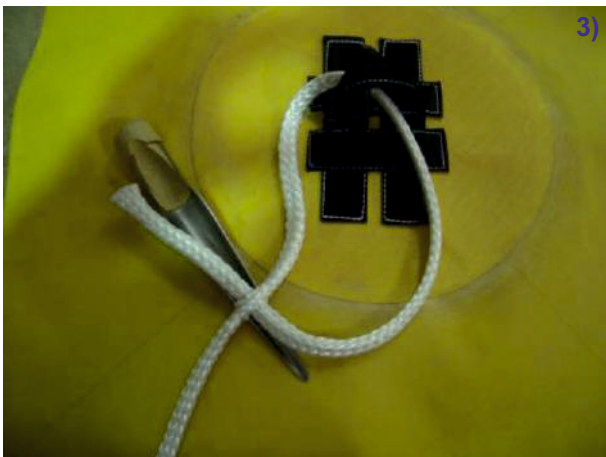

3) Using a fid, splice the line three times to secure the line to the patch.

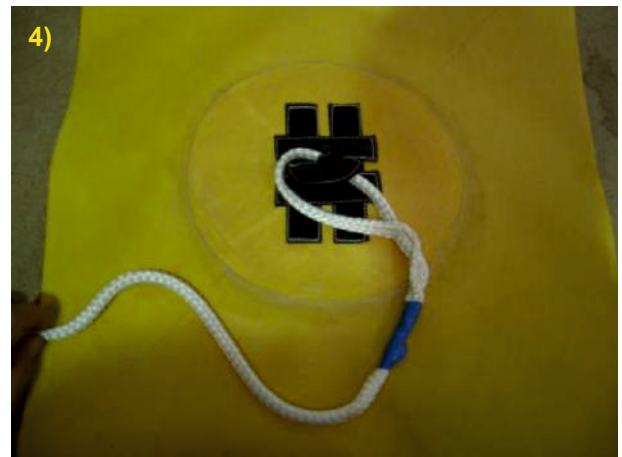

4) Tidy the line by taping the loose end of the line to the leading side.



5) Attach the drogue line to the outer life line using ball ties. Secure the line in 2 positions around the periphery of the liferaft.

Ensure that the drogue line is held between the tubes and any excess line is re-stowed inside either the drogue pouch (if fitted) or the drogue located in the front entrance of the liferaft.

Section:	Liferaft Assembly & Packing			
DATE:	31/10/2020	CREATED BY:	P.Marlow	
ISSUE:	02/2020	CHECKED BY	J.Beaumont	

6.3.4 ~ Fitting the Cylinder

1. Locate the cylinder pocket. Turn the tube over to aid access to the pocket.

Warning: At this time check that the torque drive assembly is installed in the top of the cylinder valve. Without the torque drive assembly the cylinder will not discharge and inflate the liferaft.



2. Locate the hose running from the upper buoyancy tube. Insert the threaded end into the upper most outlet on the cylinder valve.

Using a torque wrench tighten the hose into position using the torque valve 12.2Nm.

3. Locate the hose running from the lower buoyancy tube. Insert the threaded end into the lower most outlet on the cylinder valve.

Using a torque wrench tighten the hose into position using the torque valve 12.2Nm.



Section:	Liferaft Assembly & Packing			
DATE:	31/10/2020	CREATED BY:	P.Marlow	
ISSUE:	02/2020	CHECKED BY	J.Beaumont	

6.3.5 ~ Fitting of Operating Head

Position the operating head over the valve and push down until the housing locates over the serrated diameter of the cylinder valve. DO NOT TWIST.

Locate the bolts in the head assembly and ensure that they engage the threaded inserts of the operating head via the recess in the cylinder valve.

Tighten the bolts in the operating head assembly using a calibrated torque screwdriver to a torque of 1.12Nm.



Warning: On the completion of the task the cylinder is armed. Handle with caution through the remaining procedures

Section:	Liferaft Assembly & Packing			
DATE:	31/10/2020	CREATED BY:	P.Marlow	
ISSUE:	02/2020	CHECKED BY	J.Beaumont	

6.3.6 ~ Fitting of Ultralite Cylinder & Operation Head.

Locate the cylinder pocket. Turn the tube over to aid access to the pocket.

Warning: At this time check that the torque drive assembly is installed in the top of the cylinder valve. Without the torque drive assembly the cylinder will not discharge and inflate the liferaft.

Locate the hose running from the upper buoyancy tube. Insert the threaded end into the upper most outlet on the cylinder valve.

Using a torque wrench tighten the hose into position using the torque valve in appendix 1.



Locate the hose running from the lower buoyancy tube. Insert the threaded end into the lower most outlet on the cylinder valve. Using a torque wrench tighten the hose into position using the torque valve in appendix 1.

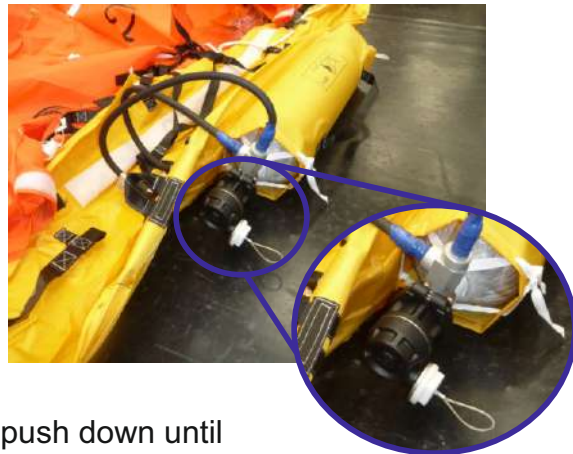

Position the operating head over the valve and push down until the housing locates over the collar of the cylinder valve. Locate the screw in the head assembly and ensure that it engages the threaded inserts of the operating head.

Tighten the bolts in the operating head assembly until resistance is felt or to a torque of 1.12Nm. Refer to appendix 3 section 7 for details.

Warning: On the completion of the task the cylinder is armed. Handle with caution through the remaining procedures

Section:	Liferaft Assembly & Packing			
DATE:	31/10/2020	CREATED BY:	P.Marlow	
ISSUE:	02/2020	CHECKED BY	J.Beaumont	

6.3.7 ~ Securing the Emergence Pack

Securing equipment - Ensure that the entrance to the liferaft is secured open. Ensure that the cylinder pocket is turned back over to sit face down.

1) Insert the equipment pack into the liferaft. the pack is positioned inside the entrance to the liferaft, no wider than the cylinder and as tight to the bottom of the lower buoyancy chamber.

1a)

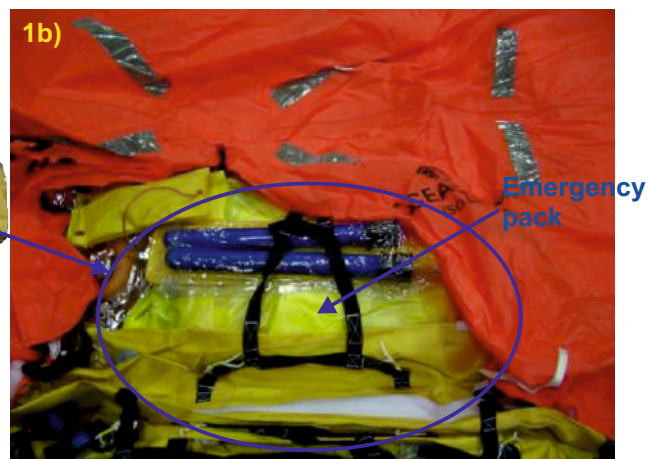

2) Tie the equipment pack onto the right hand side inner lifeline (as you look in from the entrance). Secure the pack using a double hitch.



3) Position the oars on top of the equipment pack and secure to the same inner life line. Place the drogue on top of the oars (either packed inside the drogue pouch or on earlier models with the line stowed inside the drogue).

Gather the boarding ladder up and place with the folds between the chambers. Raise the cylinder slightly to locate ties underneath it.

Warning: Ensure that the emergency pack is located tightly in position and is not allowed to move throughout the packing process. If the pack moves the shape of the packed liferaft will not be correct. If this occurs the packing process must be undone, the pack repositioned and the procedure repeated.

Section:	Liferaft Assembly & Packing			 OCEAN SAFETY®
DATE:	31/10/2020	CREATED BY:	P.Marlow	
ISSUE:	02/2020	CHECKED BY	J.Beaumont	

6.4 ~ Painter

6.4.1 ~ Attaching Pinter “Firing Lines” Mk 2 - October 2020

The firing wire & vacuum bag have changed as part of the update for the Ocean ISO liferaft with Mk2 container. This means the painter line will need firing lines attached.

The firing lines are made up of one length of 300mm 2.8mm cord.

These need to be anchored into position on the Painter where the red end meets the white. Using a Fid to make a hole in the Painter. Fig.1,

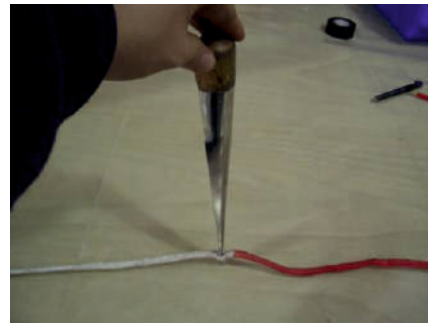

Fold the Firing line in half & pass through the hole of the painter using the fid to assist you Fig.2. Pull through so you have a small loop in the firing line Fig.3.



Pass the two ends of the firing line through the loop & pull tight. Fig.4.
Now secure the firing line in position using tape Fig.5

Once the painter line has been prepared then, locate the Vacuum Bag Firing Wire Clip.

Secure both firing lines separately to the Vacuum Bag Firing Wire Clip using overhand knots. The tap the loose ends to together.

Section:	Liferaft Assembly & Packing			 OCEAN SAFETY®
DATE:	31/10/2020	CREATED BY:	P.Marlow	
ISSUE:	02/2020	CHECKED BY	J.Beaumont	

6.4.2 ~ Packing the Painter into the Pocket.

If re-packing an old painter line, check the condition of the line prior to re-packing. If there is any damage present, replace the assembly rather than packing.

Take the painter line pouch and locate the coloured section of the line in the pouch first. Lay the line on the bottom of the pouch positioning the non coloured section out the side of the pouch.

800mm of uncoloured painter line

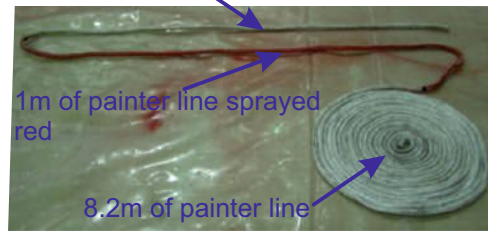

Flake the remainder of the line into the pouch on top of the red line. Leave approximately 1m of line trailing from the other side of the pouch.

Tall End which has the red showing attaches to the painter bridle



Working end that goes through the container / Valise

Note. The diagrams on this page do not show the Firing lines attached to the painter.

Section:	Liferaft Assembly & Packing			
DATE:	31/10/2020	CREATED BY:	P.Marlow	
ISSUE:	02/2020	CHECKED BY	J.Beaumont	

Section ~ 7

Assembly and Packing

Ocean ISO / Ocean ISO Ultralite Liferafts

Including the Mk2 Container

Section:	Liferaft Assembly & Packing			
DATE:	31/10/2020	CREATED BY:	P.Marlow	
ISSUE:	02/2020	CHECKED BY	J.Beaumont	

Section 6 ~ Liferaft Assembly and packing

All modifications to the following sections shall be recorded in the table provided below. Once a new section is issued, replace the old version of the manual and destroy the obsolete pages.

Revision N°	Sections Affected	Issue Date	Inserted Date	Signature
Rev 0109	6.1, 6.5.1, appendix 1 to 4	02.06.09		C.Perks
Rev 1010	6.6 incorporated	07.10.10		C.Perks
Rev 0414	6.1,	30.04.14		J.Beaumont
02/2020	Complete update including the Mk2 container & the relevant enhancements	31/10/2020	31/10/2020	P.Marlow

Section:	Liferaft Assembly & Packing			
DATE:	31/10/2020	CREATED BY:	P.Marlow	
ISSUE:	02/2020	CHECKED BY	J.Beaumont	

7 ~ Assembly and Packing

7.1~ Folding Procedure for Ocean ISO Liferafts

- 7.1.1 ~ 4 Person ISO Liferaft, Folding Procedure
- 7.1.2 ~ 6/8 Person ISO Liferaft, Folding Procedure
- 7.1.3 ~ 10/12 Person ISO Liferaft, Folding Procedure

7.2 ~ Packing Liferaft in to Vacuum Bag

- 7.2.1 ~ Positioning Liferaft in to Vacuum Bag, Mk1
- 7.2.2 ~ Positioning Liferaft in to Vacuum Bag, Ultralite
- 7.2.3 ~ Positioning Liferaft in to Vacuum Bag, Mk1

7.3 ~ Arming the Firing System

- 7.3.1 ~ Arming the Firing System Mk1 (Loop Firing Wire)
- 7.3.2 ~ Arming the Firing System Ultralite (Loop Firing Wire)
- 7.3.3 ~ Arming the Firing System Mk2 (Twin Ball Firing Wire)

7.4 ~ Packing the Liferaft into Container / Valise

- 7.4.1 ~ Positioning the Liferaft in the Container
- 7.4.2 ~ Painter Pouch Positioning
- 7.4.3 ~ Securing the Container Mk1
- 7.4.4 ~ Packing Ultralite into the Container
- 7.4.5 ~ Packing Mk2 into Container
- 7.4.6 ~ Packing ISO Valise
- 7.4.7 ~ Packing ISO Ultralite Valise

Section:	Liferaft Assembly & Packing			 OCEAN SAFETY®
DATE:	31/10/2020	CREATED BY:	P.Marlow	
ISSUE:	02/2020	CHECKED BY	J.Beaumont	

7.1 ~ Folding Procedure for Ocean ISO Liferafts

The folding procedure for the Ocean ISO / ISO Ultralite are all the same.

7.1.1 ~ 4 Person, ISO Liferaft, Folding Procedure

Securing equipment - Ensure that the entrance to the liferaft is secured open. Ensure that the cylinder pocket is turned back over to sit face down.

1) Insert the equipment pack into the liferaft. The pack is positioned inside the entrance to the liferaft, no wider than the cylinder and as tight to the bottom of the lower buoyancy chamber.

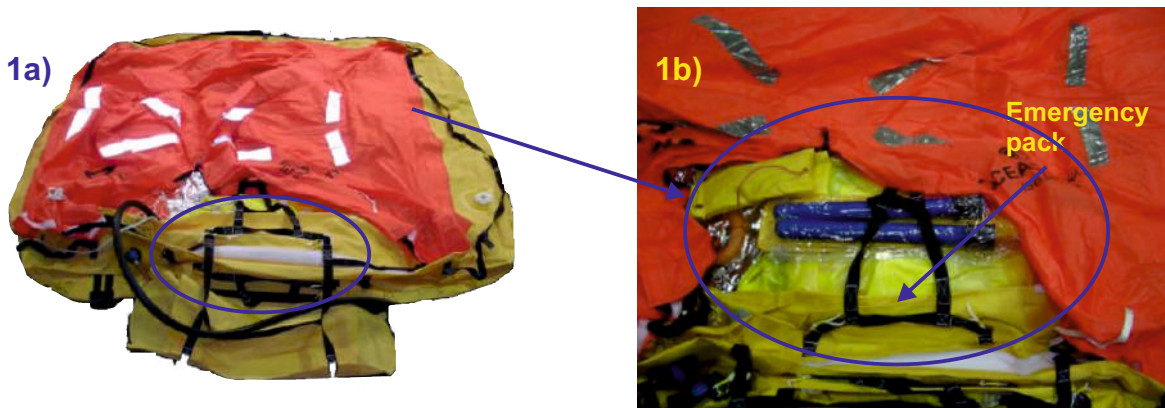

2) Tie the equipment pack onto the right hand side inner lifeline (as you look in from the entrance). Secure the pack using a double hitch.

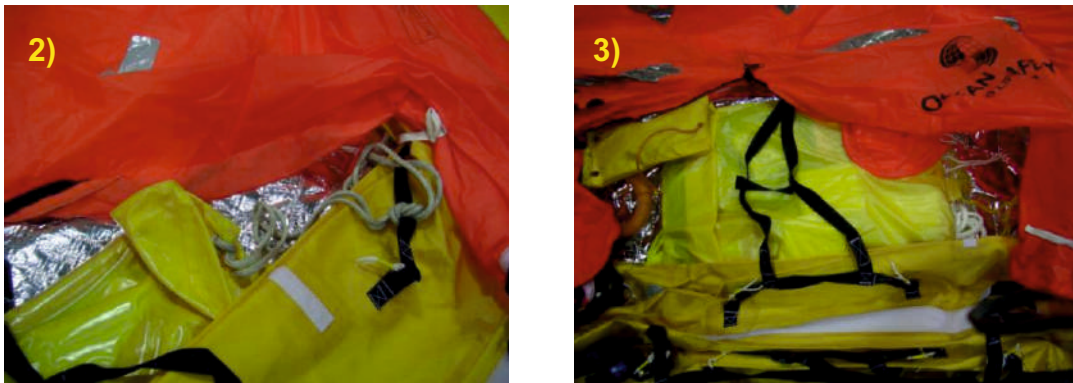

3) Position the oars on top of the equipment pack and secure to the same inner life line. Place the drogue on top of the oars (either packed inside the drogue pouch or on earlier models with the line stowed inside the drogue).

Gather the boarding ladder up and place with the folds between the chambers. Raise the cylinder slightly to locate ties underneath it. Place one under the cylinder at the operating head end and one at the bottom of the cylinder. Run the tie back towards the rear of the liferaft.

Warning: Ensure that the emergency pack is located tightly in position and is not allowed to move throughout the packing process. If the pack moves the shape of the packed liferaft will not be correct. If this occurs the packing process must be undone, the pack repositioned and the procedure repeated.

Section:	Liferaft Assembly & Packing			 OCEAN SAFETY®
DATE:	31/10/2020	CREATED BY:	P.Marlow	
ISSUE:	02/2020	CHECKED BY	J.Beaumont	

4 Person, ISO Liferaft Folding Procedure, cont.



Fig 1

1) Starting from the operating head side of the liferaft, fold the liferaft along a fold line that runs perpendicular to the cylinder depicted by the dashed line above.

2) Once folded flatten the area ensuring that the layers of the liferaft are as flat as possible expelling trapped air. Straighten the water pockets in preparation for the next fold.

3) The second fold line is depicted above by the dashed line. The fold is to run from the base of the cylinder. Fold the layers up onto the assembled layers formed by fold 1.

4) Before moving to the next stage of packing ensure that all folds are assembled neatly, all water pockets are laid out neatly and as much as possible is expelled from the folds.



Fig 2

Fig 3

Operating head

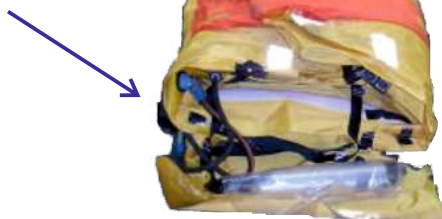



Fig 4



5) Move to the rear of the Liferaft. The liferaft will be folded twice before being inserted into the vacuum bag. Once fold over and one fold up onto the emergency pack. At this stage ensure that all folds remain straight to avoid excess fabric jutting out or bulges.

Make the first fold as depicted in fig 4. Ensure that the fold ends just short of of the emergency pack.

Section:	Liferaft Assembly & Packing			
DATE:	31/10/2020	CREATED BY:	P.Marlow	
ISSUE:	02/2020	CHECKED BY	J.Beaumont	

4 Person ISO, Liferaft Folding Procedure, cont.

6) The final fold is to be made up onto the area of the liferaft containing the emergency pack. A second person will make this process easier. One person folds the liferaft up into position, the other person receives the fold and pulls them tight to the end, level with the front of the liferaft. Once again use pressure to expel trapped air from the folds of the liferaft.

Fig 5

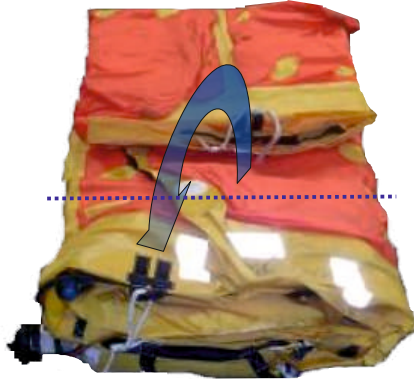

7) Make sure that the hoses are tucked in away in the folds of the raft & that they are no extreme bend that could result in damage to the high pressure hose.

Fig 6



8) Use temporary tie fabric to secure the folds in position, this will assist with getting the raft into the vacuum bag.



Section:	Liferaft Assembly & Packing			 OCEAN SAFETY®
DATE:	31/10/2020	CREATED BY:	P.Marlow	
ISSUE:	02/2020	CHECKED BY	J.Beaumont	

7.1.2 ~ 6/8 Person, ISO Liferaft Folding Procedure

Securing equipment - Ensure that the entrance to the liferaft is secured open. Ensure that the cylinder pocket is turned back over to sit face down.

1) Insert the equipment pack into the liferaft. the pack is positioned inside the entrance to the liferaft, no wider than the cylinder and as tight to the bottom of the lower buoyancy chamber.

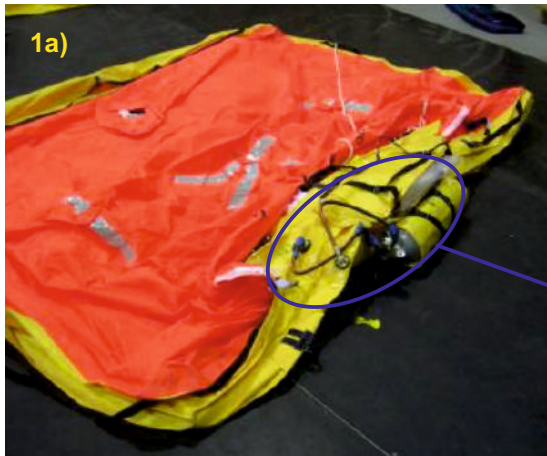

2) Tie the equipment pack onto the right hand side inner lifeline (as you look in from the entrance). Secure the pack using a double hitch.

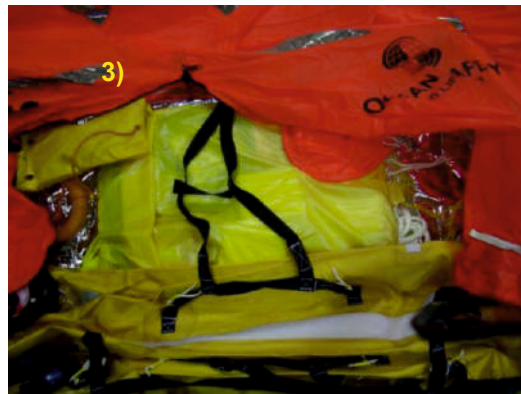

3) Position the oars on top of the equipment pack and secure to the same inner life line. Place the drogue on top of the oars (either packed inside the drogue pouch or on earlier models with the line stowed inside the drogue).

Gather the boarding ladder up and place with the folds between the chambers. Raise the cylinder slightly to locate ties underneath it. Place one under the cylinder at the operating head end and one at the bottom of the cylinder. Run the tie back towards the rear of the liferaft.

Warning: Ensure that the emergency pack is located tightly in position and is not allowed to move throughout the packing process. If the pack moves the shape of the packed liferaft will not be correct. If this occurs the packing process must be undone, the pack repositioned and the procedure repeated.

Section:	Liferaft Assembly & Packing			 OCEAN SAFETY®
DATE:	31/10/2020	CREATED BY:	P.Marlow	
ISSUE:	02/2020	CHECKED BY	J.Beaumont	

6/8 Person ISO Liferaft Folding Procedure, cont.

1) Starting from the operating head side of the liferaft, fold the liferaft along a fold line that runs perpendicular to the cylinder depicted by the dashed line above.

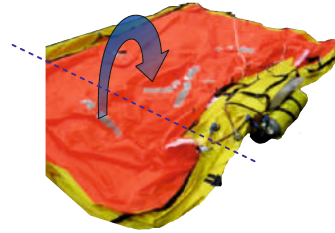

Fig 1

2) Straighten the water pockets in preparation for the next fold.

Fig 2



3) The second fold line is depicted above by the dashed line. The fold is required to reduce the width of the folded raft.

Fig 3



4) The third fold line is depicted above by the dashed line. The fold is intended to reduce the width of the folded liferaft.

Fig 4



5) The fourth fold line is depicted above by the dashed line. The fold is to run from the base of the cylinder. Fold the layers up onto the assembled layers formed by folds 1 and 2.

Section:	Liferaft Assembly & Packing			 OCEAN SAFETY®
DATE:	31/10/2020	CREATED BY:	P.Marlow	
ISSUE:	02/2020	CHECKED BY	J.Beaumont	

6/8 Person ISO Liferaft Folding Procedure, cont.

6) Move to the rear of the Liferaft. The liferaft will be folded three times before being inserted into the vacuum bag. Twice folded over and one fold up onto the emergency pack. At this stage ensure that all folds remain straight to avoid excess fabric jutting out or bulges.

Fig 5



Make the first fold as depicted in fig 5. Ensure that the fold ends just short of the next water pocket.

Fig 6



7) Make the second fold as depicted in fig 6. Ensure that the folds remain straight, tidy and all air is expelled.

6) The final fold is to be made up onto the area of the liferaft containing the emergency pack. A second person will make this process easier. One person folds the liferaft up into position, the other person receives the fold and pulls them tight to the end, level with the front of the liferaft. Once again use pressure to expel trapped air from the folds of the liferaft.

Fig 7



Fig 8



7) Use the ties to secure the folds in position for the handling required in the next stage of packing.

Assembly the hoses as depicted in figure 9. Ensure there are no extreme bend radiuses that could result in damage to the high pressure hose.



Fig 9

Section:	Liferaft Assembly & Packing			
DATE:	31/10/2020	CREATED BY:	P.Marlow	
ISSUE:	02/2020	CHECKED BY	J.Beaumont	

6.4.3 ~ 10/12 Person, ISO Liferaft Folding Procedure

Securing equipment - Ensure that the entrance to the liferaft is secured open. Ensure that the cylinder pocket is turned back over to sit face down.

1) Insert the equipment pack into the liferaft. The pack is positioned inside the entrance to the liferaft, no wider than the cylinder and tight to the bottom of the lower buoyancy chamber.

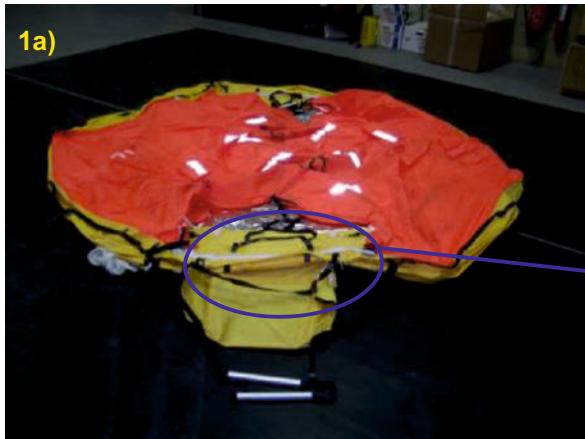

2) Tie the equipment pack onto the right hand side inner lifeline (as you look in from the entrance). Secure the pack using a double hitch.



3) Position the oars on top of the equipment pack and secure to the same inner life line. Place the drogue on top of the oars (either packed inside the drogue pouch or on earlier models with the line stowed inside the drogue).

Gather the boarding ladder up and place with the folds between the chambers. Raise the cylinder slightly to locate ties underneath it. Place one under the cylinder at the operating head end and one at the bottom of the cylinder. Run the tie back towards the rear of the liferaft.

Warning: Ensure that the emergency pack is located tightly in position and is not allowed to move throughout the packing process. If the pack moves the shape of the packed liferaft will not be correct. If this occurs the packing process must be undone, the pack repositioned and the procedure repeated.

Section:	Liferaft Assembly & Packing			
DATE:	31/10/2020	CREATED BY:	P.Marlow	
ISSUE:	02/2020	CHECKED BY	J.Beaumont	

10/12 Person, ISO Liferaft Folding Procedure, cont

1) Starting from the operating head side of the liferaft, fold the liferaft along a fold line that runs perpendicular to the cylinder depicted by the dashed line above.



2) Straighten the water pockets in preparation for the next fold.

3) The second fold line is depicted above by the dashed line. The fold is required to reduce the width of the folded raft. Fold the edge of the liferaft back along the dashed line depicted above.

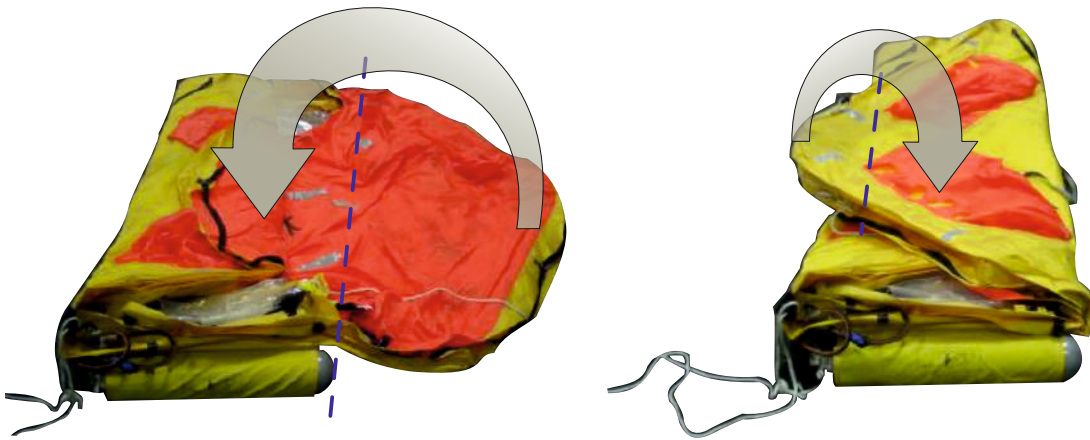

4) The third fold line is depicted above by the dashed line. The fold runs perpendicular from the base of the cylinder.

5) Straighten the water pockets in preparation for the next fold.

6) The third fold line is depicted adjacent by the dashed line. The fold is required to reduce the width of the packed raft. Fold the edge of the liferaft back along the dashed line depicted above.

Section:	Liferaft Assembly & Packing			 OCEAN SAFETY®
DATE:	31/10/2020	CREATED BY:	P.Marlow	
ISSUE:	02/2020	CHECKED BY	J.Beaumont	

10/12 Person ISO Liferaft Folding Procedure, cont

7) Move to the rear of the Liferaft. The liferaft will be folded four times before being inserted into the vacuum bag. The raft will be folded over 3 times and one fold up onto the emergency pack. At this stage ensure that all folds remain straight to avoid excess fabric jutting out or bulges. While folding ensure that hard components are not packed upon one another, for example ensure that the PRV's are space so that they sit side by side rather than on top of one another.



8) Make the second fold of this process along the line depicted. Ensure that all folds and water pockets are neat and in line. Try to keep the folds tight as you progress.

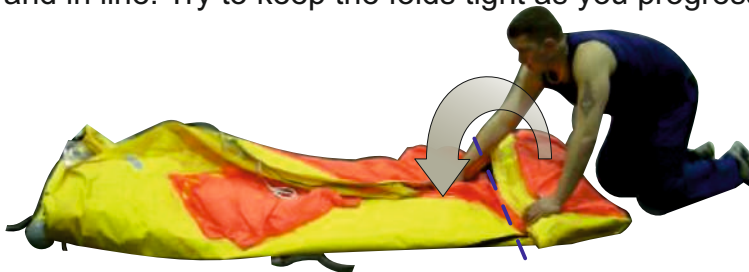

9) Make the 3rd fold of this process along the line depicted. Ensure that all folds and water pockets are neat and in line. Try to keep the folds tight as you progress.

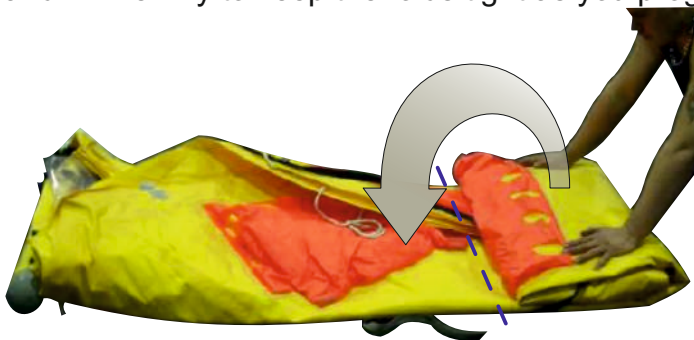

Section:	Liferaft Assembly & Packing			 OCEAN SAFETY®
DATE:	31/10/2020	CREATED BY:	P.Marlow	
ISSUE:	02/2020	CHECKED BY	J.Beaumont	

10/12 Person ISO Liferaft Folding Procedure, cont

10) Make the forth fold up onto the emergency pack. Ensure as with the steps previously, all folds are in line and water pockets are straight. With the folds assembled correctly, use the packing strap to retain the folds through the vacuum bag packing process.



Ensure that the operating head is packed as depicted below. Ensure that there are not extreme bend radiuses that could result in damage to the high pressure hoses.



Section:	Liferaft Assembly & Packing			 OCEAN SAFETY®
DATE:	31/10/2020	CREATED BY:	P.Marlow	
ISSUE:	02/2020	CHECKED BY	J.Beaumont	

7.2 ~ Packing Liferaft in to Vacuum Bag

7.2.1 ~ Positioning the liferaft inside the Vacuum Bag Mk1

1) The vacuum bag features one open end, a flange, 2 eyelets and a valve. the valve is welded to the top of the bag and must face up. The operating head locates into the flange. The eyelets are used to secure the painter line and the painter line pocket. Fig.1 below refers.

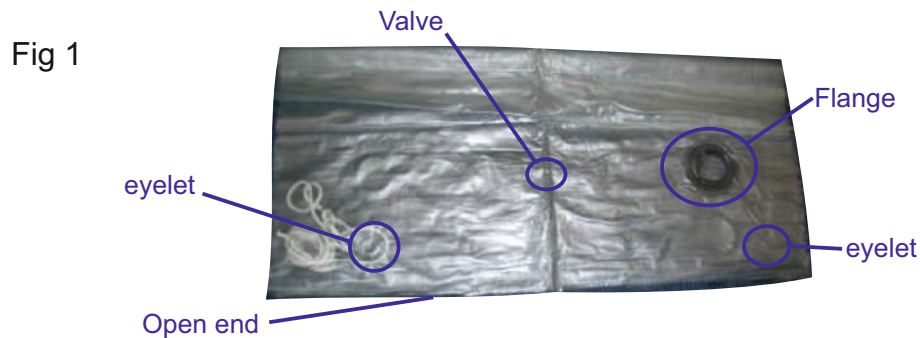

The 4 person vacuum bag shall be trimmed to aid inflation. vacuum bags are supplied with a trim line welded into the upper layer of the bag. If the trim line cannot be located, follow the instructions below.

Trim in between the eyelets down perpendicular to the open end of the bag by 150mm. Once both sides are trimmed, cut across in-between to remove the panel. FIG 2 refers.

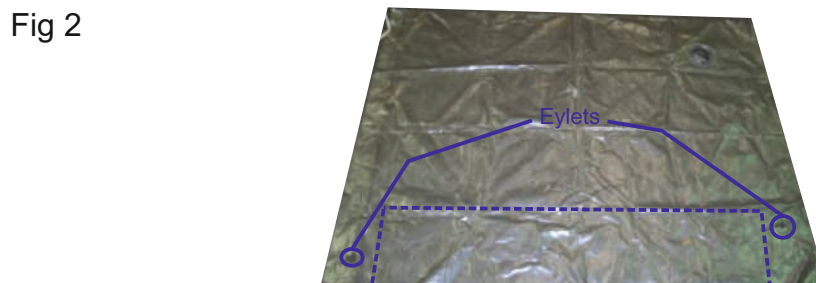

2) Take the line supplied with the vacuum bag and run the length around the eyelet inside the vacuum bag.

3) Thread one of loose ends of rope through the painter patch eyelet. Tie the two ends together using a hitch.

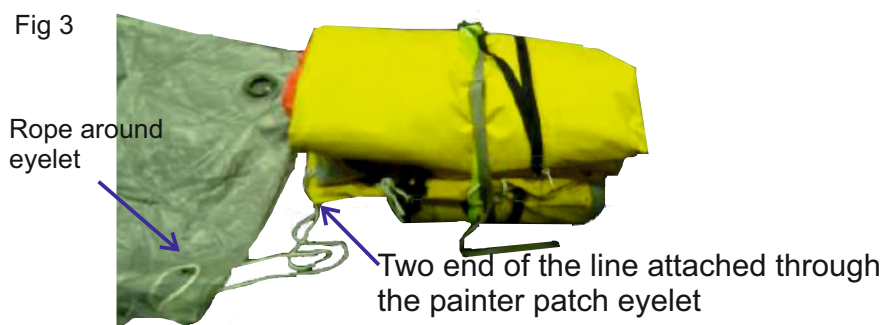

Section:	Liferaft Assembly & Packing			 OCEAN SAFETY®
DATE:	31/10/2020	CREATED BY:	P.Marlow	
ISSUE:	02/2020	CHECKED BY	J.Beaumont	

4) Locate the operating head through the flange. Ensure that the O ring supplied with the vacuum bag is in position on between the operation head and the flange on the inside of the bag.

Fig 4



Position the folded liferaft inside the vacuum bag and secure the operating head in position using the cable ties supplied with the vacuum bag.

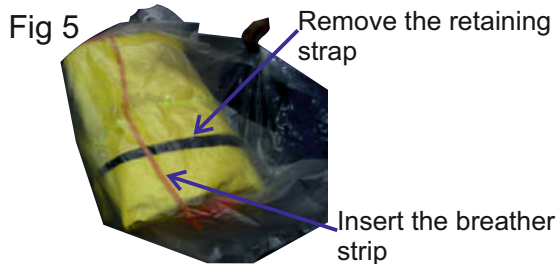

5) Remove the securing straps from around the packed liferaft. Fig 5 refers

6) Position a breather strip under the valve of the vacuum bag. Fig 5 refers

Fig 6

7) Take up the two layers of film that make up the open end of the bag. Ensure that the overlap is level. Fig 6 refers

Pull the layers tight to remove any pleats or creases.

Slide the RF welder over the ends of the bag. allow the jaws to close onto the bag. Release the tension held on the bag by your other hand.



With the tension released from the bag active the RF welder to seal the bag.

Continue the process until the bag is welded closed.

Warning - Do not attempt to weld the bag shut while applying any transverse or longitudinal tension. Failure to realise all tension will result in damage to the vacuum bag.

Section:	Liferaft Assembly & Packing			 OCEAN SAFETY®
DATE:	31/10/2020	CREATED BY:	P.Marlow	
ISSUE:	02/2020	CHECKED BY	J.Beaumont	

7.2.2 Positioning the Ultralite liferaft inside the vacuum bag

1) The vacuum bag features one open end, a open hole an eyelet and a valve. The valve is to be the top of the bag. The operating head is located through the open hole and the eyelet is used for the painter and firing line (see fig 1).

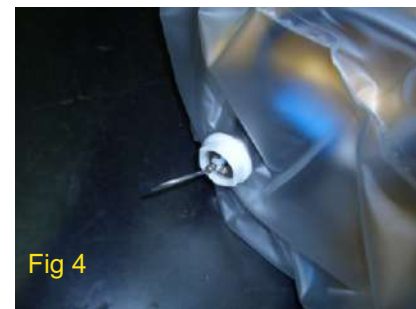
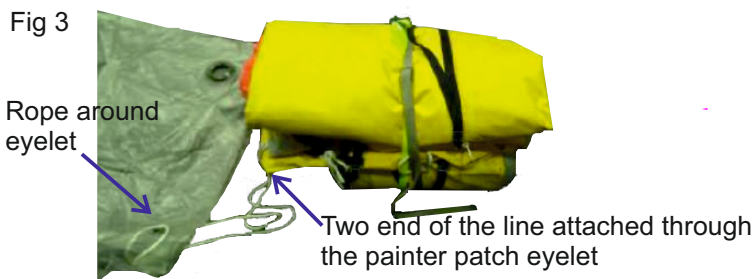
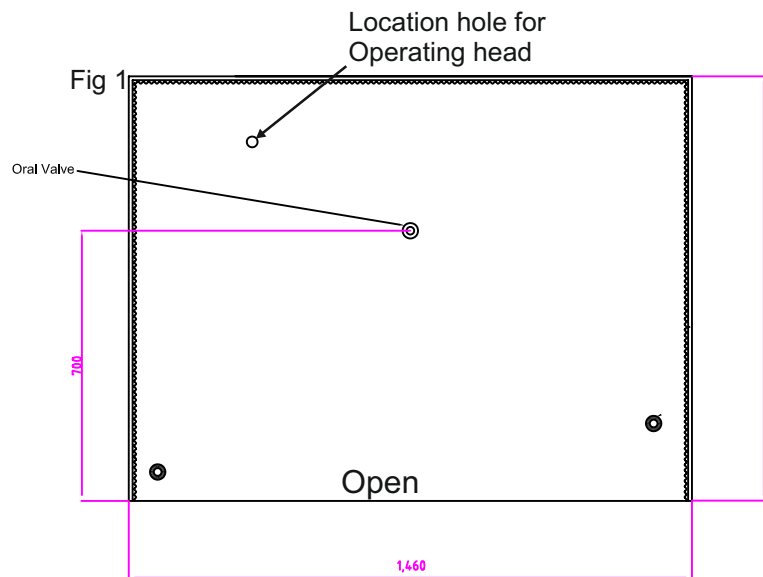

2) Take the line supplied with the vacuum bag and run the length around the eyelet inside the vacuum bag.

3) Thread one of loose ends of rope through the painter patch eyelet. Tie the two ends together using a hitch.

4) Insert the liferaft inside the vacuum bag so that the cylinder is at the bottom of the folded liferaft and of the correct orientation to locate the operating head through open hole is the bag.

locate the locking nut over the threaded section protruding out of the vacuum bag. Engage the threads and tighten to the torque specified in appendix 2.

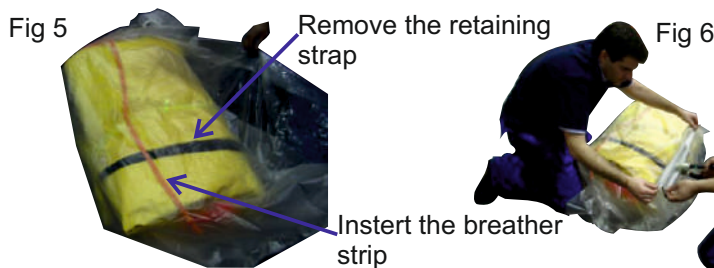

5) Remove the securing straps from around the packed liferaft. Fig 5 refers

6) Position a breather strip under the valve of the vacuum bag. Fig 5 refers

7) Take up the two layers of film that make up the open end of the bag. Ensure that the overlap is level. Fig 6 refers

8) Pull the layers tight to remove any pleats or creases.

9) Slide the RF welder over the ends of the bag. Allow the jaws to close onto the bag. Release the tension held on the bag by your other hand.

10) With the tension released from the bag active the RF welder to seal the bag.

11) Continue the process until the bag is welded closed.

Warning - Do not attempt to weld the bag shut while applying any transverse or longitudinal pressure. Failure to release all tension will result in damage to the vacuum bag.

Section:	Liferaft Assembly & Packing			
DATE:	31/10/2020	CREATED BY:	P.Marlow	
ISSUE:	02/2020	CHECKED BY	J.Beaumont	

7.2.3 ~ Positioning the raft in to the Vacuum Bag ~ Post October 2020

1) Firstly lay the Vacuum bag out so that you can locate the firing wire sleeve in advance to putting the raft into the vacuum bag. Also to check the securing line is attached.



Firing wire sleeve Eyelet

2) Take the line supplied with the vacuum bag and run the length around the eyelet inside the vacuum bag.



3) Thread one of loose ends of rope through the painter patch eyelet. Tie the two ends together using a hitch.

4) Slide the raft in to the vacuum bag. once fully into the bag rotate the bag to align the firing wire sleeve of the vacuum bag with the operating head firing wire.

Slid the vacuum bag sleeve over the firing wire.



Caution: Be careful not to pull the Operating Head Firing Wire as this active the cylinder.

Section:	Liferaft Assembly & Packing			
DATE:	31/10/2020	CREATED BY:	P.Marlow	
ISSUE:	02/2020	CHECKED BY	J.Beaumont	

5) Hold the sleeve of the vacuum bag, in position over the ball of the firing wire, fit the Vacuum Bag Firing Wire Clip and secure it using a Pozi screwdriver.

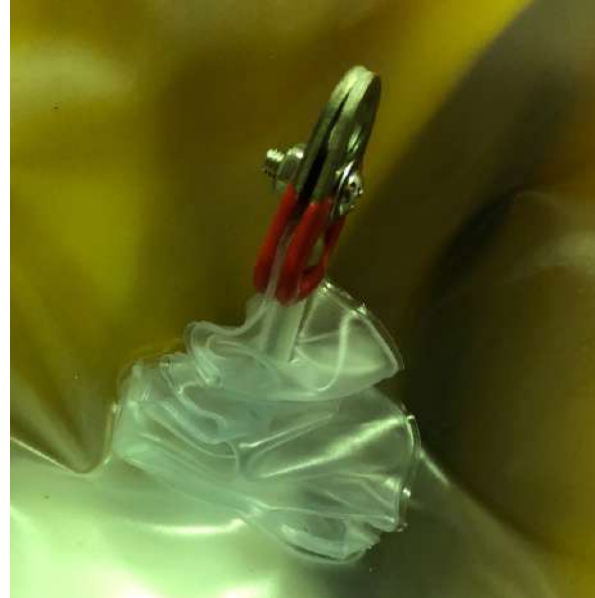

6) Once the Firing Wire clip has been fitted lay the raft on the floor, remove any pleats & seams from the vacuum bag to make it easier to seal the vacuum bag with sealing tongs.

7) Now locate the vacuum bag plug for attaching the vacuum pump, place the mesh sleeve between the vacuum bag & the raft, to help assist the air extraction. To keep the mesh sleeve in position you may find it easier to use some tape.

Caution: Do not pull the vacuum bag around the firing wire clip.



7) Pull the layers tight to remove any pleats or creases.

Slide the RF welder over the ends of the bag, allow the jaws to close onto the bag.

Release the tension held on the bag by your other hand. With the tension released from the bag activate the RF welder to seal the bag.

Continue the process until the bag is welded closed.

Warning: Do not attempt to weld the bag shut while applying any transverse or longitudinal tension. Failure to realise all tension will result in damage to the vacuum bag.

Section:	Liferaft Assembly & Packing			 OCEAN SAFETY®
DATE:	31/10/2020	CREATED BY:	P.Marlow	
ISSUE:	02/2020	CHECKED BY	J.Beaumont	

7.3 ~ Arming the Firing System

7.3.1 ~ Arming the firing system Mk1 (Loop Firing Wire) ~ Pre 2020

1) Locate the tail end of the painter line. The tail end runs from the bottom of the pouch, and the running end comes from the top of the pouch.

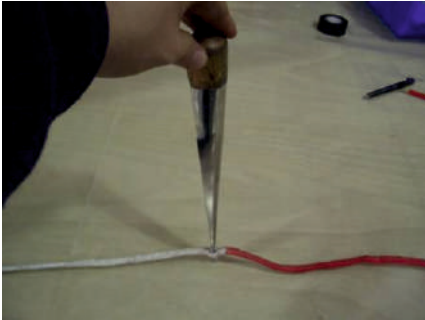

To the painter line pouch

To the strong point on the vacuum bag.



2) The tail end of the painter line has a coloured section.



At the beginning of this coloured section split the line using a Fid. Slide the actuator pin up the groove in the Fid, feeding the loop of the pin through the hole in the painter line.



3) Remove the Fid leaving the loop of the pin through the middle of the painter line.

Section:	Liferaft Assembly & Packing			
DATE:	31/10/2020	CREATED BY:	P.Marlow	
ISSUE:	02/2020	CHECKED BY	J.Beaumont	

4) Feed the tail end of the painter line back through the loom of the firing pin and secure with tape.



5) The tail end is to be located through the eyelet on the vacuum pouch. Once this is through the eyelet, fasten to the strong point by splicing the line.



Line to the painter patch

Tail end of the line running from painter pouch. Splice the line looping both the eyelet & the line from the painter patch.

Warning: This operation involves working with the actuation device of the gas inflation system. Caution must be exercised not to accidentally fire the system. No force must be brought to the firing pin that will result in the pin being removed from the operating head.

Section:	Liferaft Assembly & Packing			 OCEAN SAFETY®
DATE:	31/10/2020	CREATED BY:	P.Marlow	
ISSUE:	02/2020	CHECKED BY	J.Beaumont	

7.3.2 ~ Arming the Ultralite GIS Firing System

1) Locate the tail end of the painter line. The tail end runs from the bottom of the painter pouch and features the red coloured section of line. The leading end comes from the top of the pouch and is uncoloured.

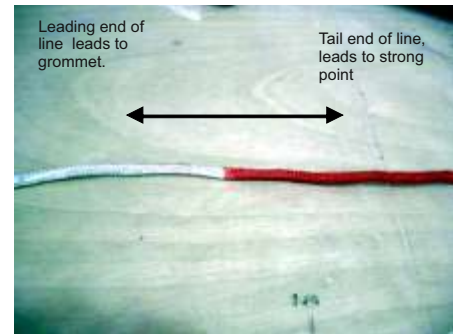

The coloured section of the line runs from the bottom of the pouch back to the uncoloured section.

The uncoloured section is 8 feet long.

Locate the firing pin and the strong point

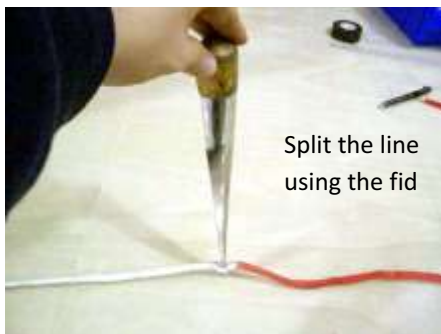

Split the line using the fid

2) Where the two sections of red and uncoloured line meet, use the fid to split the braiding of the line.

3) With the fid split the line and slide the end of the firing pin up through the hole in the line just created.

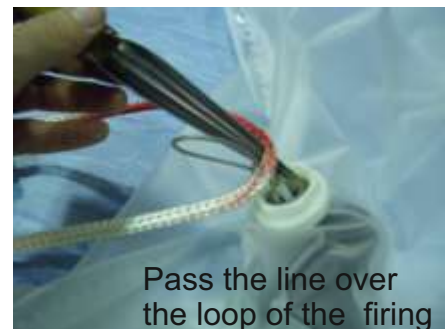

Pass the line over the loop of the firing



Remove the fid leaving the line over the pin.

4) Remove the fid so that the line is left located over and around the firing pin.

Section:	Liferaft Assembly & Packing			
DATE:	31/10/2020	CREATED BY:	P.Marlow	
ISSUE:	02/2020	CHECKED BY	J.Beaumont	

5) Pass the tail end of the painter line back through the eye of the firing pin.

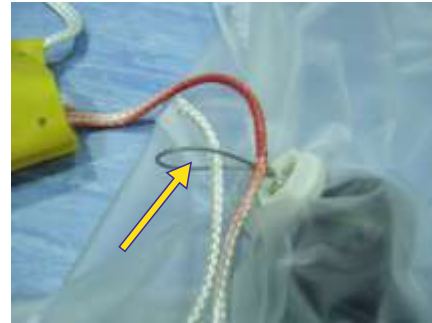

6) Bring the two layers together.

7) Tape the tail end of the line together with the final part of the coloured section.

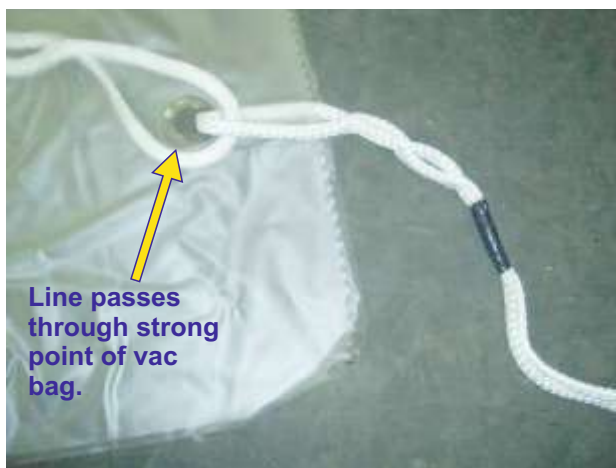

7) Tail end of the line running from painter pouch. Pass it through the strong point of the vacuum bag & loop back on its self & then Spliced the line together. Having spliced 3 tucks tape the end to the painter.

Section:	Liferaft Assembly & Packing			
DATE:	31/10/2020	CREATED BY:	P.Marlow	
ISSUE:	02/2020	CHECKED BY	J.Beaumont	

7.3.3 ~ Attaching the Painter (Ball Firing Wire) Mk2

1) Prepare the painter with firing lines
in accordance with Section 6 Para.6.4.1



2) Once the painter line has been prepared then, locate the Vacuum Bag Firing Wire Clip.

3) Secure both firing lines separately to the Vacuum Bag Firing Wire Clip using overhand knots.

4) Then tape the loose ends to together



Section:	Liferaft Assembly & Packing			
DATE:	31/10/2020	CREATED BY:	P.Marlow	
ISSUE:	02/2020	CHECKED BY	J.Beaumont	

7.4 ~ Packing Liferaft into Container

7.4.1 ~ Positioning the Liferaft in the container

With the airline still connected, offer up the liferaft to see container and check the fit. If required release the vacuum and the bag will re-inflate. Once there is air back in the bag, reconnect the vacuum pump and work the packed unit into the correct shape.

Position the lower half of the container next to the liferaft. The lower half of the container features all drainage holes and the orifice for the grommet.

Locate the rubber sealing strip around the periphery of the container.



The Mk 2 containers do not have the rubber sealing strip. The bottom half is fitted with guides & once the container is closed, the gap is taped.

Position a layer of 3mm foam in the bottom half of the container. Ensure that the length of foam is sufficient to full encompass the folded liferaft.

Lift the liferaft into the container and position the liferaft so that the operating head is next to the open hole.



Section:	Liferaft Assembly & Packing			
DATE:	31/10/2020	CREATED BY:	P.Marlow	
ISSUE:	02/2020	CHECKED BY	J.Beaumont	

7.4.2 ~ Painter Pouch Positioning.

Position the painter line pouch down by the side of the packed liferaft in line and parallel with the cylinder. Position the pouch so that the open end is facing the drilled hole in the container with the tail end of the line is the same side as the cylinder.



Secure the pouch to the strong point located on the vacuum bag.
 Pass the end of the painter through the hole of the container.
 Then get the container grommet & pass the painter through its centre & fit to the container.



Reconnect the vacuum if required. Remove the vacuum pump once the liferaft is reduced to the required size. Locate the sealing cap of the valve. Position the foam around the liferaft so that the liferaft is completely encompassed.

Section:	Liferaft Assembly & Packing			
DATE:	31/10/2020	CREATED BY:	P.Marlow	
ISSUE:	02/2020	CHECKED BY	J.Beaumont	

7.4.3 ~ Securing the Container

Position the top half of the container over the assembled bottom half ensuring that the 3mm foam does not protrude from inside the liferaft.

Locate the edge of the container into the groove in the sealing strip. Run the strap of the ratchets over the top of the container.

Locate these in the ratchets and compress the top half of the container down onto the bottom. Work around the container with a spatula tool and ensure that the sealing strip has located properly.



Once the sealing strip is correctly installed, take two lengths of strapping and run them under the container.

Locate the strapping in the tool and tighten. Place the fid under the top edge of the strapping to make the following processes easier.

Once the correct tension has been applied locate a strapping seal over the strapping at the edge of the container. Use the seal crimping tool to close the seals.



Use scissors to cut the excess strapping on both sides of the seal.

Cover the seals with electrical tape and remove the fid.

Section:	Liferaft Assembly & Packing			 OCEAN SAFETY®
DATE:	31/10/2020	CREATED BY:	P.Marlow	
ISSUE:	02/2020	CHECKED BY	J.Beaumont	

7.4.4 ~ Packing Ultralite into the Container

- With the liferaft packed into the vacuum bag and wrap in foam, locate the liferaft into the lower half of the container.
- Locate the painter line through the grommet on the side of the container. Leave approximately 0.5m of line coiled up outside of the container.
- Locate the top of the container over the liferaft.
- Position the ratchet straps around the container. Ensure the surface of the container is protected against damage from the straps
- Carefully compress the container until the two halves but up against each other.
- With the ratchet straps in-place turn the container upside down to fit the packing straps.
- Take a length of packing strap and using the banding tool install two straps in the slots provided. Ensure that the surface of the container is protected from the banding tool.
- Cover the banding clips with heat shrink covers and use the heat gun to carefully form the covers to the shape of the clips. Be careful to not use too much heat as this will result in damage to the banding.
- With the banding in place turn the container back over and remove the ratchet straps.
- Run a layer of black tape around the join between the two halves of container.
- Locate and stick the self adhesive labels to the container. Fill out the label as prescribed in section - Service information and Data Label.



Section:	Liferaft Assembly & Packing			 OCEAN SAFETY®
DATE:	31/10/2020	CREATED BY:	P.Marlow	
ISSUE:	02/2020	CHECKED BY	J.Beaumont	

7.4.5 ~ Securing Mk2 Liferaft into the Container

The Mk2 container, bottom half are fitted with guides to assist with the positioning of the top. It doesn't have the rubber sealing strip, the two halves just butt together.

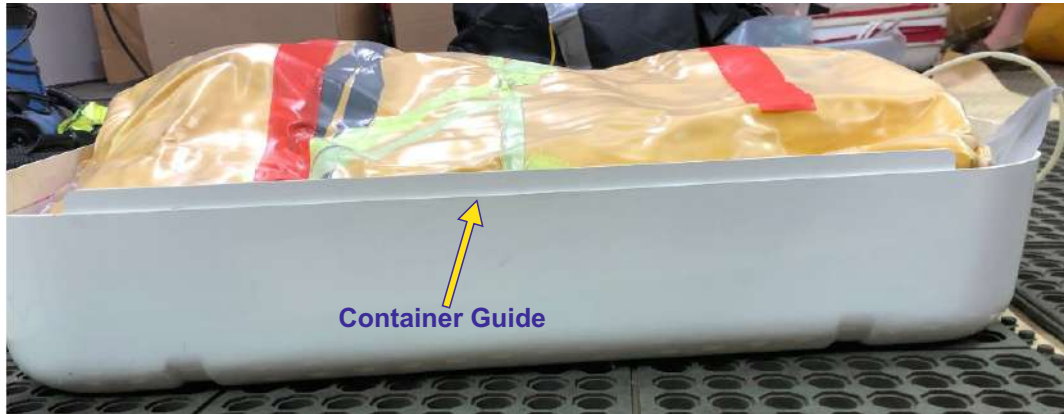

Make sure the liferaft has been extracted of air as best as possible & that it fits in to the container. Making sure that the position of the Painter is near the hole of the container.

Position the painter pocket in such a position to allow the painter to run freely from the pouch. Pass the end of the painter through the hole of the container & then fit the grommet.



Place the top half in to position. Making sure that all the liferaft & vacuum bag are tucked inside the container before starting the banding.

Section:	Liferaft Assembly & Packing			 OCEAN SAFETY®
DATE:	31/10/2020	CREATED BY:	P.Marlow	
ISSUE:	02/2020	CHECKED BY	J.Beaumont	

You may need to use the ratchets to keep the container together to assist with banding. Follow how to carry out the banding which is covered in Section 7.4.3. The only change to this procedure is that the banding is secured on top in the middle. This reduces the risk of damage to the top container being face down.

Once the banding is in place then use OSL8080 Adhesive Tape to seal the gap between the two halves.



Secure the painter to the outside of the container to prevent being caught in transit.



Section:	Liferaft Assembly & Packing			 OCEAN SAFETY®
DATE:	31/10/2020	CREATED BY:	P.Marlow	
ISSUE:	02/2020	CHECKED BY	J.Beaumont	

7.4.6 ~ Packing ISO Valise



Locate the vacuum over the valve positioned on the top of the vacuum bag. Start to remove the air inside the bag.

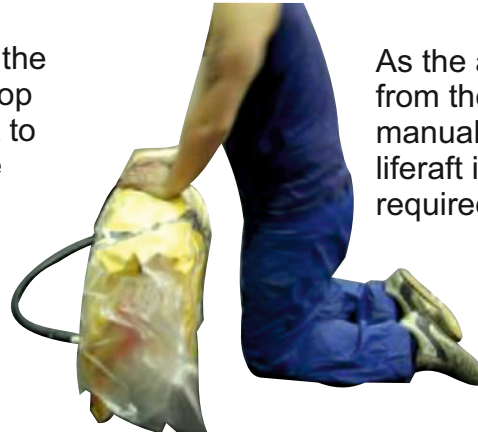

As the air is extracted from the bag, manually mould the liferaft into the required shape.

With the airline still connected, offer up the liferaft to the container and check the fit. If required release the vacuum and the bag will re-inflate. Once there is air back in the bag, reconnect the vacuum pump and work the packed unit into the correct shape. Position the Valise next to the liferaft with the half featuring the punched hole at the bottom. Run a layer of 3mm in the bottom half of the valise. ensure the foam is long enough to fully wrap around the liferaft.



Position the painter line pouch down by the side of the packed liferaft in line and parallel with the cylinder. Position the pouch so that the open end is facing the grommet in the valise with the tail end of the line is the same side as the cylinder.

Secure the pouch to the strong point located on the vacuum bag.

Take the running end of the painter line and run it from the to the grommet located by the top of the operating head. Pass the line through the grommet leaving approximately 50cm of line outside the end of the valise.



Section:	Liferaft Assembly & Packing			
DATE:	31/10/2020	CREATED BY:	P.Marlow	
ISSUE:	02/2020	CHECKED BY	J.Beaumont	



Reconnect the vacuum pump if the liferaft requires further adjustment to fit into the valise. Remove the vacuum pump and install the sealing cap in the oral valve on the top of the vacuum bag.



Close the second half of the valise on top of the folded liferaft with the 3mm foam in place around the liferaft.



Run the zips around and off of the end of the zipper.



Before threading the break thread ensure that the zip is run completely off of the end of the zipper.

Section:	Liferaft Assembly & Packing			
DATE:	31/10/2020	CREATED BY:	P.Marlow	
ISSUE:	02/2020	CHECKED BY	J.Beaumont	

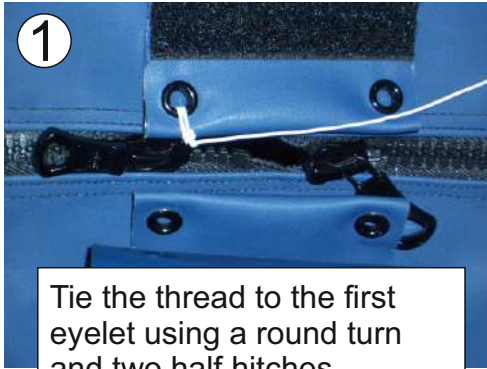

1 Tie the thread to the first eyelet using a round turn and two half hitches



2 Thread the line through the eyelet on the zipper.

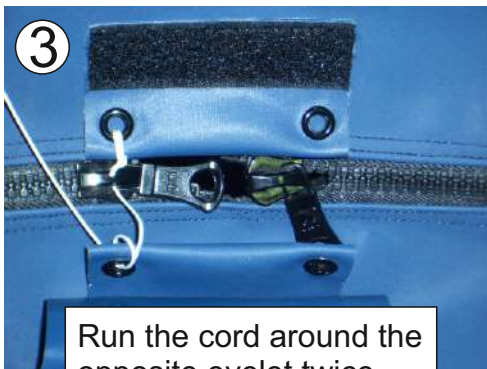

3 Run the cord around the opposite eyelet twice.

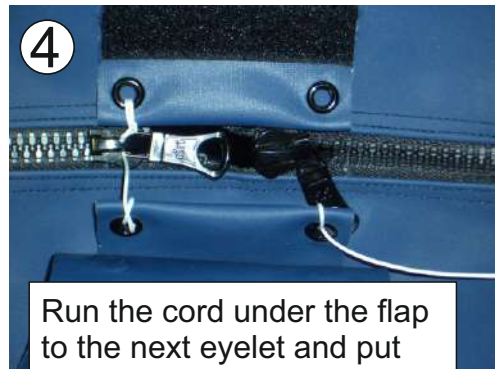

4 Run the cord under the flap to the next eyelet and put two turns around it.

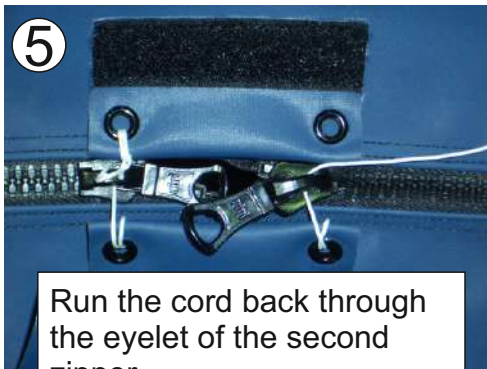

5 Run the cord back through the eyelet of the second zipper.



6 Tie the thread to the last eyelet using a round turn and two half hitches



7 Once the cord is tied, cut the excess cord from the tail end of the cord.

Warning

Before starting point 1 ensure that the zippers are pulled right to the end of both zip tracks. Failure to do this can result in a failed or obstructed inflation.

Section:	Liferaft Assembly & Packing UltraLite		
DATE:	02.06.09	CREATED BY:	C.Perks
ISSUE:	04.14	CHECKED BY	C.Waterman

7.4.7 ~ Packing ISO Ultralite Valise

Wrap the packed liferaft in foam.

Position the valise over the packed liferaft. Orientate the valise and liferaft so that cylinder is at the bottom of the valise with the operating head and actuation cable pointing in the direction of the grommet.

Take the leading end of the painter line and thread it through the grommet. Leave approximately 0.5m outside of the valise. Coil the line and tidy using an elastic band.

Engage the zips and run the zips right around to the end of the zip tracks. Note that one of the tracks is longer than the other. This is a deliberate feature to induce a mode of failure across the zips when the liferaft inflates. Make sure the zip is run to the end of the longer track.

Thread the zippers and eyelets as per standard Ocean ISO Liferaft.

Place the flap over the zip.



Run the zips right to the end of the track, note that one track is longer than the other. Run the zip to the end of the longer zip track.

Once complete thread the zips with the break tie as per the standard Ocean ISO.

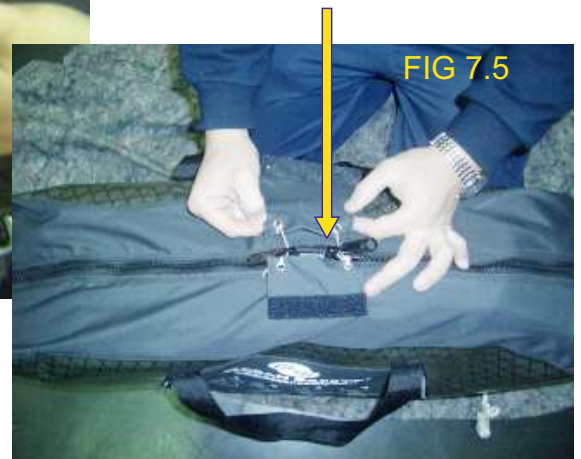

Section:	Service Information & Data Label			
DATE:	31/10/2020	CREATED BY:	P.Marlow	
ISSUE:	02/2020	CHECKED BY	J.Beaumont	

Section ~ 8

Service Information & Data Labels

Ocean ISO / Ocean ISO Ultralite Liferrafts

Including Mk1 & Mk2 Containers

Section:	Service Information & Data Label			 OCEAN SAFETY®
DATE:	31/10/2020	CREATED BY:	P.Marlow	
ISSUE:	02/2020	CHECKED BY	J.Beaumont	

Modifications Log - Service Information & Data Label

All modifications to the following sections shall be recorded in the table provided below. Once a new section is issued, replace the old version of the manual and destroy the obsolete pages.

Revision N°	Sections Affected	Issue Date	Inserted Date	Signature
Rev 1010	7.2 & 7.4	07.10.2010		C. Perks
Rev 0612	Editorial review	30.04.2014		J.Beaumont
02/2020	Complete update including the Mk2 container & the relevant enhancements	31/08/2020	31/08/2020	P.Marlow

Section:	Service Information & Data Label			
DATE:	31/10/2020	CREATED BY:	P.Marlow	
ISSUE:	02/2020	CHECKED BY	J.Beaumont	

8 ~ Service Information & Data Labels

8.1 ~ Introduction

8.2 ~ Manufactures recommended service intervals

8.3 ~ Container Labels

- 8.3.1 ~ Ocean ISO Mk1 Labels
- 8.3.2 ~ Ocean ISO Ultralite Mk1 Labels
- 8.3.3 ~ Ocean ISO Mk2 Labels
- 8.3.4 ~ Ocean ISO Ultralite Mk2 Labels

8.4 ~ Labels, Explained

- 8.4.1 ~ Ocean ISO & ISO Ultralite Mk1 ID & Instruction Label
- 8.4.2 ~ Ocean ISO & ISO Ultralite Mk2 ID & Instruction Label
- 8.4.3 ~ Grab Bag Pack Contents Label

8.5 ~ Alignment of Labels

- 8.5.1 ~ Ocean ISO Mk1 label Arrangement
- 8.5.2 ~ Ocean ISO Ultralite M1 Label Arrangement
- 8.5.3 ~ Ocean ISO & Ultralite Mk2 Label Arrangement

8.6 ~ Valise Labels

- 8.6.1 ~ Valise Data Labels
- 8.6.2 ~ Valise Label Arrangement

8.7 ~ Liferaft Serial Number

Section:	Service Information & Data Label			 OCEAN SAFETY®
DATE:	31/10/2020	CREATED BY:	P.Marlow	
ISSUE:	02/2020	CHECKED BY	J.Beaumont	

8 ~ Service Information & Data Labels

8.1 ~ Introduction

This section details the information externally visible once the liferaft is packed. This information will be used by the owner of the liferaft and service personal at service intervals and as such should be complete using the dyno machine fitted with UV stable paper and ink.

The labels shall be completed and assembled to the liferafts so that all information is correctly completed and clear.

8.2 ~ Manufactures Recommended Service Intervals

The following service intervals are the manufactures recommended maximum service intervals for average use in average conditions. If the liferaft is exposed to extreme conditions it is recommended that the length of the service interval is reduced accordingly.

Where the liferaft is being used to conform to Flag Administration approved regulations, the service guide lines laid out by the Flag Administration shall be followed up to a maximum length of the interval stated buy the manufacturer.

With the changes to the Ocean ISO especially the vacuum bag the service intervals have been increased:

Service Intervals: Every 3 years up to 18 years then annually. Hydrostatic Cylinder Test to remain and conducted when necessary, likely to be 3rd service after 9 years.

	Service Interval 1	Service Interval 2	Service Interval 3	Service Interval 4	Service Interval 5	Service Interval 6	Service Interval 7	Service Interval 8 Onwards
Years of service after commissioning	Year 3	Year 6	Year 9	Year 12	Year 15	Year 18	Year 19	Year 20
Ocean ISO	3 years	3 years	3 years	3 years	3 years	3 years	Annual	Annual
Ocean ISO Ultralite	3 years	3 years	3 years	3 years	3 years	3 years	Annual	Annual

Our service interval remains 3 years but is restricted by the inclusion of a dated First Aid Kit. The First Aid kit or any other dated item does not change our recommended service interval.

Section:	Service Information & Data Label			 OCEAN SAFETY®
DATE:	31/10/2020	CREATED BY:	P.Marlow	
ISSUE:	02/2020	CHECKED BY	J.Beaumont	

8.3 ~ Container Labels

8.3.1 ~ Ocean ISO Mk1 Labels

OS ISO Container Label Set, Contained within the Service Kit.

Ocean ISO Container Mk1 ID & Instructions Label

OCEAN ISO LIFERAFT ISO 9650-1, GROUP A.				 OCEAN SAFETY®	
Vessel Name: _____					
No. of Persons:	Painter Length:		Last Served:		
Pack Type:	> 24 H	< 24 H	SOLAS B	Served by:	
Serial No:			Next Service:		
 <small>Attach painter to STROB point & deploy the liferaft overboard!</small>		 <small>FULL painter charge to inflate</small>		 <small>CUT painter to release Liferaft</small>	

Ocean Safety Label



Contents Label

Name Of Vessel		
<input style="width: 100%;" type="text"/>		
<small>This ISO Liferaft Is Equipped In accordance with the requirements of ISO 9650-1. Additional Equipment May Be Carried In an associated GRAB BAG.</small>		
Associated Grab Bag		
Equipment	LR	GB
Paddles	2	
Baler	1	
Sponge	2	
Whistle	1	
Torch Spare Bulb & Batt	2	
Signal Mirror	1	
Anti Sea Sick Pills	60	
Sea Sick Bag (1 per person)		
Hand Flare Red	3	
Parachute Flare Red	1	
Operation/Survival Inst	1	
Repair Kit	1	
Pump	1	
Drinking Water (0.5L/Pers)		
Scissors		
Buoyant Smoke Signals		
Thermal Protective Aid		
Food Ration (10000J/Pers)		
Sea Anchor - Spare		
Fishing Kit		
Drinking Vessel		
Radar Reflector		
First Aid Kit ISO		
First Aid Kit 'Cat C'		
International Signal Card		

No Step Label x 2



Section:	Service Information & Data Label			 OCEAN SAFETY®
DATE:	31/10/2020	CREATED BY:	P.Marlow	
ISSUE:	02/2020	CHECKED BY	J.Beaumont	

8.3.2 ~ Ocean ISO Ultralite Mk1 Labels

Ocean ISO Ultralite Mk1 Data & Instruction Label

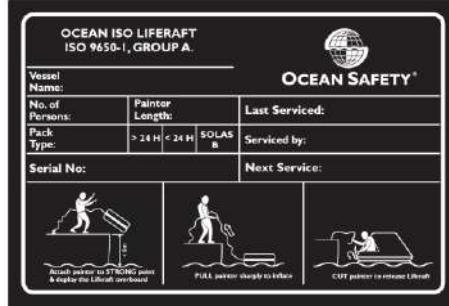

Ocean Safety Ultralite Logo

Second edition



First edition



No Step Label x2



Section:	Service Information & Data Label			 OCEAN SAFETY®
DATE:	31/10/2020	CREATED BY:	P.Marlow	
ISSUE:	02/2020	CHECKED BY	J.Beaumont	

8.3.2 ~ Ocean ISO Mk2 Labels.

Ocean ISO Container Mk2 ID & Instructions Label

OCEAN SAFETY®
OCEAN ISO LIFERAFT
ISO 9650-1, GROUP A.

VESSEL NAME:		SERIAL NO.:		LAST SERVICED:	
PACK TYPE:	LAUNCH HEIGHT:	PAINTER LENGTH:	NO. OF PERSONS:	SERVICED BY:	
< 24 H	< 6m			NEXT SERVICE:	
> 24 H	> 6m				
SOLAS B					
<small>DO NOT STEP ON BAIT OR DEEP OTHER THAN FOR DEPLOYMENT</small>					
					
1 ATTACH PAINTER TO A STRONG POINT AND DEPLOY			2 PULL PAINTER LINE SHARPLY TO INFLATE		
					
3 BOARD LIFERAFT, AIM FOR CANOPY			4 CUT PAINTER TO FREE LIFERAFT		

Ocean Safety Logo Label x2



Contents Label

Name Of Vessel		
<input style="width: 100%;" type="text"/>		
This ISO Liferaft is Equiped in accordance with the requirements of ISO 9650-1. Additional Equipment May Be carried in an associated GRAB BAG.		
Associated Grab Bag		
Equipment	LR	GB
Paddles	2	
Baler	1	
Sponge	2	
Whistle	1	
Torch, Spare Bulb & Batt'	2	
Signal Mirror	1	
Anti Sea Sick Pills	60	
Sea Sick Bag (1 per person)		
Hand Flare Red	3	
Parachute Flare Red	1	
Operation/Survival Inst'	1	
Repair Kit	1	
Pump	1	
Drinking Water (0.5L/Pers')		
Scissors		
Buoyant Smoke Signals		
Thermal Protective Aid		
Food Ration (10000J/Pers')		
Sea Anchor - Spare		
Fishing Kit		
Drinking Vessel		
Radar Reflector		
First Aid Kit ISO		
First Aid Kit 'Cat C'		
International Signal Card		

No Step Label x 2



Section:	Service Information & Data Label			 OCEAN SAFETY®
DATE:	31/10/2020	CREATED BY:	P.Marlow	
ISSUE:	02/2020	CHECKED BY	J.Beaumont	



8.4 ~ Label, Explained

8.4.1 ~ Ocean ISO / Ultralite Mk1 ID & Instructions Label

Fill out with appropriate liferaft capacity

Complete with 9m painter line length

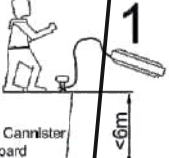
Leave blank unless the vessels name is known at the time of service.

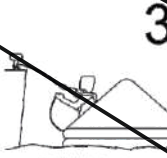
LIFERAFT				
OCEAN ISO 9650 -1, Group A.			Ocean Safety Limited T: +44(0) 23 807 20900 www.oceansafety.com F: +44(0) 23 807 20901	
No. of Persons:	Painter Length:	Name of Vessel:		
Pack Type		Date Last Served:		
ISO 1 >24 hr	ISO 2 <24 hr	SOLAS B	Served By:	
Serial Number:		Date of Next Service:		
 Throw Cannister Overboard <6m	 PULL Painter Sharply to Inflate Liferaft.	 Cut Painter to Release Liferaft.		

Insert date of last service

Insert the name of the service station undertaking the service work.

Please refer to table 7.2 for details

Add the term **GRAB BAG** if applicable.

Complete with the liferafts serial number - refer to log card for details

Select the correct box for the pack type inside the left and black out the remaining two.

Section:	Service Information & Data Label			 OCEAN SAFETY®
DATE:	31/10/2020	CREATED BY:	P.Marlow	
ISSUE:	02/2020	CHECKED BY	J.Beaumont	

8.4.2 ~ Ocean ISO & Ultralite Mk2 Liferaft, Data & Instruction Label ~ Post 2020

With the arrival of the new containers brings with it a new design Data & Instruction labels, providing a clearer label for information.

Both the ISO & ISO Ultralite Data & Instruction label has the same information

The following information needs to be completed by Service Stations when servicing the liferaft.



OCEAN SAFETY®

**OCEAN ISO LIFERAFT
ISO 9650-1, GROUP A.**

Vessels Name:
If known

Serial No.
Serial no. of the liferaft

Last Service:
Date of service carried out

Serviced By:
Name of Service Station conducting the Service

No. of Persons:
Capacity of the liferaft

Painter length:
Complete with 9m of painter line.

Pack Type:
Cover over the two boxes that are not applicable.

VESSEL NAME:		SERIAL NO.:		LAST SERVICED:		<small>Version 1 CSL0802</small>
PACK TYPE:	LAUNCH HEIGHT:	PAINTER LENGTH:	NO. OF PERSONS:	SERVICED BY:		
<input type="checkbox"/> < 24 H <input type="checkbox"/> > 24 H <input type="checkbox"/> SOLAS B				<input type="text"/>		
<small>DO NOT STEP ON RAFT OR DROP OTHER THAN FOR DEPLOYMENT</small>						
						
1 ATTACH PAINTER TO A STRONG POINT AND DEPLOY			2 PULL PAINTER LINE SHARPLY TO INFLATE			
						
3 BOARD LIFERAFT, AIM FOR CANOPY			4 CUT PAINTER TO FREE LIFERAFT			

Section:	Service Information & Data Label			 OCEAN SAFETY®
DATE:	31/10/2020	CREATED BY:	P.Marlow	
ISSUE:	02/2020	CHECKED BY	J.Beaumont	

8.4.3 ~ Grab Bag Pack Contents Label

Name Of Vessel

This ISO Liferaft is Equiped in accordance with the requiremensts of ISO 9650-1. Additional Equipment May Be carried in an associated GRAB BAG.

Associated Grab Bag

Equipment	LR	GB
Paddles	2	
Baler	1	
Sponge	2	
Whistle	1	
Torch,Spare Bulb & Batt'	2	
Signal Mirror	1	
Anti Sea Sick Pills	60	
Sea Sick Bag (1 per person)		
Hand Flare Red	3	
Parachute Flare Red	1	
Operation/Survival Inst'	1	
Repair Kit	1	
Pump	1	
Drinking Water (0.5L/Pers')		
Scissors		
Buoyant Smoke Signals		
Thermal Protective Aid		
Food Ration (10000J/Pers')		
Sea Anchor - Spare		
Fishing Kit		
Drinking Vessel		
Radar Reflector		
First Aid Kit ISO		
First Aid Kit 'Cat C'		
International Signal Card		

Print the name of the vessel if known. If not known leave the box blank

If grab bag is required denote box with **Yes**

The column marked GB is reserved for the content of the grab bag. If any of the required emergency pack content is stowed inside a grab bag the column is to be marked accordingly.

The column marked LR is reserved for the content of the emergency pack inside the liiferaft. Equipment that makes up the pack is denoted accordingly in the table.

At the bottom of the table there are blank spaces so that not standard equipment may be added by the owner.

Section:	Service Information & Data Label			 OCEAN SAFETY®
DATE:	31/10/2020	CREATED BY:	P.Marlow	
ISSUE:	02/2020	CHECKED BY	J.Beaumont	

8.5 ~ Alignment of Labels

8.5.1 ~ Ocean ISO Mk1 Labels Arrangement

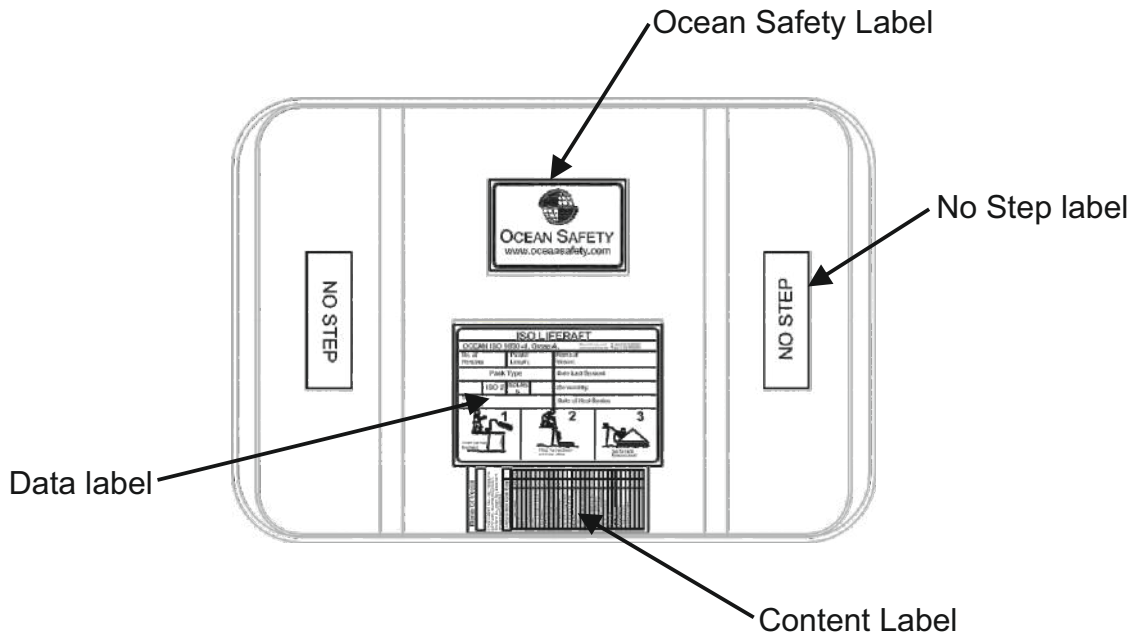

Section:	Service Information & Data Label			 OCEAN SAFETY®
DATE:	31/10/2020	CREATED BY:	P.Marlow	
ISSUE:	02/2020	CHECKED BY	J.Beaumont	

8.5.2 ~ Ocean ISO Ultralite Mk1 Label Arrangement

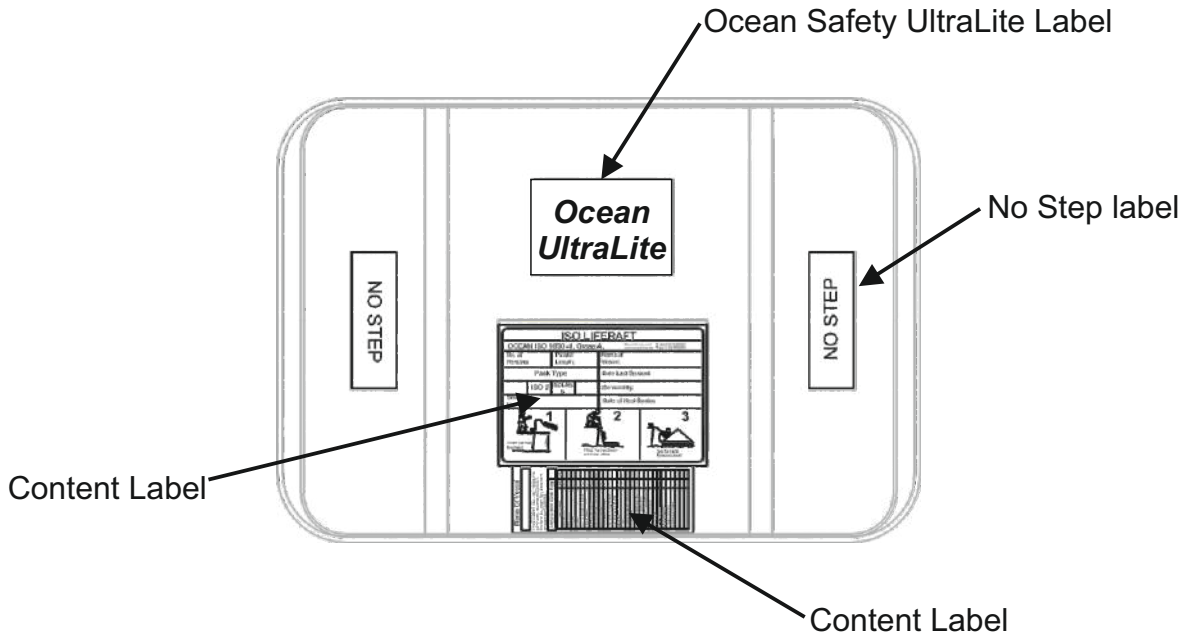

Section:	Service Information & Data Label			 OCEAN SAFETY®
DATE:	31/10/2020	CREATED BY:	P.Marlow	
ISSUE:	02/2020	CHECKED BY	J.Beaumont	

8.5.3 ~ Ocean ISO & Ultralite Mk2 Label Arrangement

Positioning of the label for the Ocean ISO & Ocean ISO Ultralite.



Ocean Safety Logo
Label to be
positioned on each
end of the container.



Section:	Service Information & Data Label			 OCEAN SAFETY®
DATE:	31/10/2020	CREATED BY:	P.Marlow	
ISSUE:	02/2020	CHECKED BY	J.Beaumont	

8.6 ~ Valise Labels

8.6.1 ~ Valise Data Label

Fill out with appropriate liferaft capacity

Complete with 9m painter line length

Insert date of last service

Insert the name of the service station undertaking the service work.

Please refer to table 7.2 for details

OCEAN ISO 9650 -1, Group A.				
No. of Persons:		Painter Length:		Ocean Safety Limited T: +44(0) 23 807 20800 www.oceansafety.com F: +44(0) 23 807 20801
Pack Type			Date Last Serviced:	
ISO 1 >24 hr	ISO 2 <24 hr	SOLAS B	Serviced By:	
Serial Number:			Date of Next Service:	

Complete with the liferafts serial number - refer to log card for details

Select the correct box for the pack type inside the left and black out the remaining two.

Add the term **GRAB BAG** if applicable.

8.6.2 ~ Valise Label Arrangement

Valise Data Label

Content label

PVC pocket

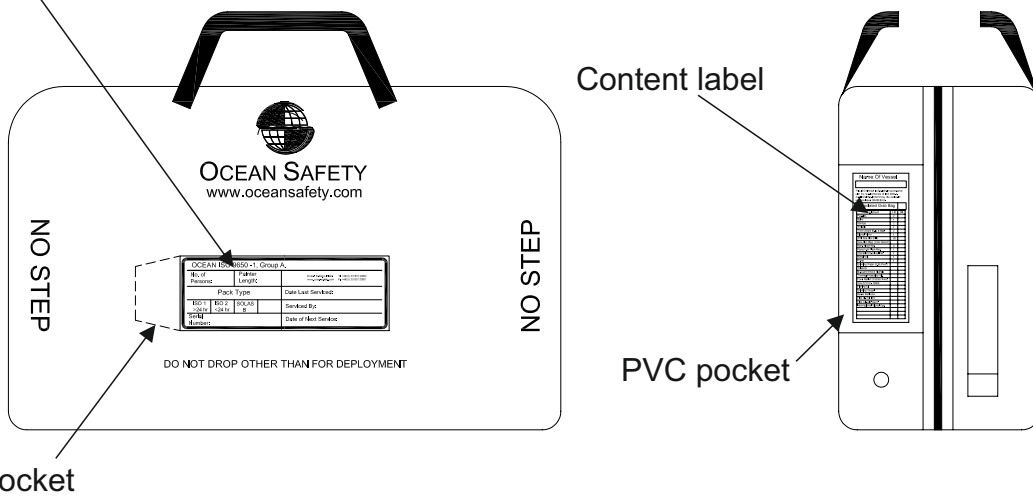

Contents Label, is the same as the container.

Section:	Service Information & Data Label			 OCEAN SAFETY®
DATE:	31/10/2020	CREATED BY:	P.Marlow	
ISSUE:	02/2020	CHECKED BY	J.Beaumont	

8.7 - Liferaft Serial Number

To complete the Liferaft serial number, fill out using the following format.

Sequential number is a serial number the liferaft is provided by the manufacturer.

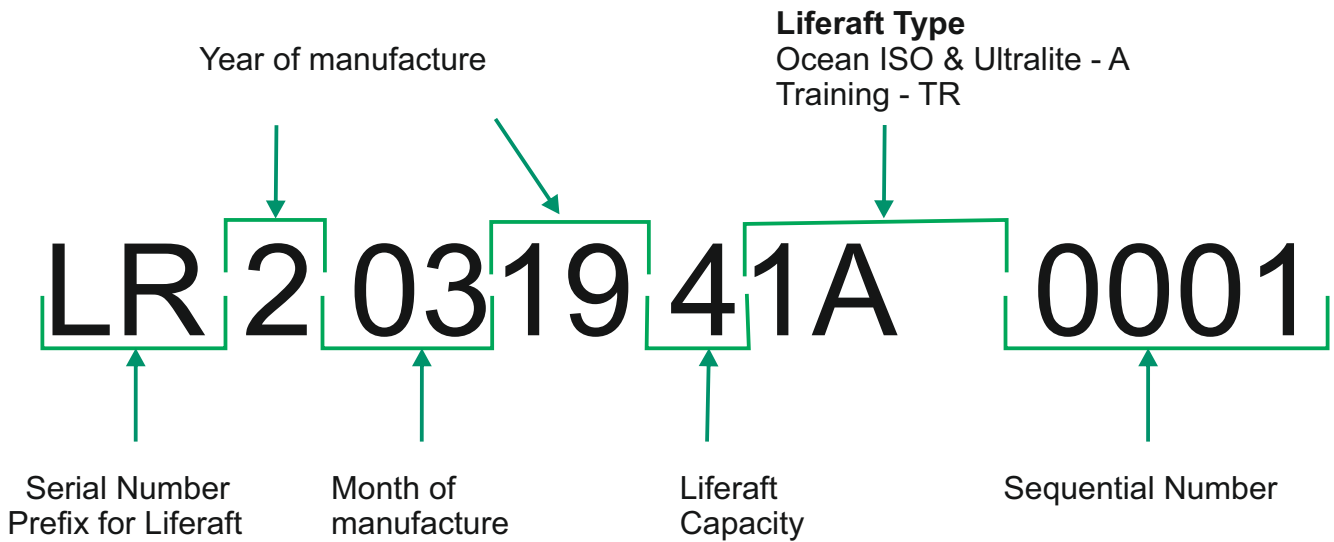

Section:	Service Spares and Tools			
DATE:	31.10.2020	CREATED BY:	P.Marlow	
ISSUE:	02.2020	CHECKED BY	J.Beaumont	OCEAN SAFETY®

Section 9

Service Spares and Tools

Ocean ISO / Ocean ISO Ultralite Liferrafts

Including Mk1 & Mk2 Containers

Section:	Service Spares and Tools			 OCEAN SAFETY®
DATE:	31.10.2020	CREATED BY:	P.Marlow	
ISSUE:	02.2020	CHECKED BY	J.Beaumont	

Section 9 ~ Service Spares & Tools

All modifications to the following sections shall be recorded in the table provided below. Once a new section is issued, replace the old version of the manual and destroy the obsolete pages.

Revision N°	Sections Affected	Issue Date	Inserted Date	Signature
Rev 0309	Tools	06.07.2009		
Rev 1010	All Sections	07.10.2010		
Rev 0414	All Sections	30.04.2014		
02/2020	Complete update including the Mk2 container & the relevant enhancements	31/10/2020	31/10/2020	P. Marlow

Section:	Service Spares and Tools			 OCEAN SAFETY®
DATE:	31.10.2020	CREATED BY:	P.Marlow	
ISSUE:	02.2020	CHECKED BY	J.Beaumont	

9 ~ Service Spare Parts List

9.1 ~ Introduction

9.2 ~ Spare Parts List

9.2.1 ~ Service Kits

9.2.2 ~ Container Kit

9.2.3 ~ Valve

9.2.4 ~ Inflation System

9.2.5 ~ Light System

9.2.6 ~ Repair

9.2.7 ~ Emergency Equipment

9.2.8 ~ Containers

9.2.9 ~ Container Kits, Complete

9.3 - Tools

Section:	Service Spares and Tools			 OCEAN SAFETY®
DATE:	31.10.2020	CREATED BY:	P.Marlow	
ISSUE:	02.2020	CHECKED BY	J.Beaumont	

9. Spare Parts List

9.2.1 ~ Service Items

Part No.	Description	Image	Details
OSL8010S	Ocean ISO Service Kit Small 4, 6, 8 Person		OS VAR Vacuum Bag, Small 4, 6, 8 Person Operating Head Firing Wire, twin ball Vacuum Bag Firing clip OS VAR ISO & JB Cord 2.8mm ~ 2100mm Vacuum Bag Mesh Sleeve Vac.Bag Painter Line 8mm flat braid per mtr x 3mtr Ocean ISO Container ID & Instr. (Old style) Ocean ISO Container ID & Instr. (New Style) Ocean ISO Container "Ocean Safety" Logo x2 Ocean "No Step" Label x2 OS ISO Pack Contents Label Container Grommet AquaSpec Service Patch Gist "O" Rings for Hoses x2 Strapping per mtr x 6Mtr Strapping clips x 2 Heat Shrink Seals x2 Bobble Ties OSL0185 x12
OSL8010L	Ocean ISO Service Kit Large 10, 12 Person		OS VAR Vacuum Bag, Large 10, 12 Person Operating Head Firing Wire, twin ball Vacuum Bag Firing clip OS VAR ISO & JB Cord 2.8mm ~ 2100mm Vacuum Bag Mesh Sleeve Vac.Bag Painter Line 8mm flat braid per mtr x 3mtr Ocean ISO Container ID & Instr. (Old style) Ocean ISO Container ID & Instr. (New Style) Ocean ISO Container "Ocean Safety" Logo x2 Ocean "No Step" Label x2 OS ISO Pack Contents Label Container Grommet AquaSpec Service Patch Gist "O" Rings for Hoses x2 Strapping per mtr x 6Mtr Strapping clips x 2 Heat Shrink Seals x2 Bobble Ties OSL0185 x12

Section:	Service Spares and Tools			 OCEAN SAFETY®
DATE:	31.10.2020	CREATED BY:	P.Marlow	
ISSUE:	02.2020	CHECKED BY	J.Beaumont	

9. Spare Parts List

9.2.1 ~ Service Items

Part No.	Description	Image	Details
OSL8015S	Ocean ISO Ultralite Service Kit Small 4, 6, 8 Person		OS VAR Vacuum Bag, Small 4, 6, 8 Person Operating Head Firing Wire, twin ball Vacuum Bag Firing clip OS VAR ISO & JB Cord 2.8mm ~ 2100mm Vacuum Bag Mesh Sleeve Vac.Bag Painter Line 8mm flat braid per mtr x 3mtr Ocean ISO UL Container ID & Instr. (Old style) Ocean ISO UL Container ID & Instr (New Style) Ocean ISO UL Container "Ocean Safety" Logo x2 Ocean UL "No Step" Label x2 OS ISO Pack Contents Label Container Grommet AquaSpec Service Patch Gist "O" Rings for Hoses x2 Strapping per mtr x 6Mtr Strapping clips x 2 Heat Shrink Seals x2 Bobble Ties OSL0185 x12 <i>Available from December 2020</i>
OSL8015L	Ocean ISO Ultralite Service Kit Large 10, 12 Person		OS VAR Vacuum Bag, Large 10, 12 Person Operating Head Firing Wire, twin ball Vacuum Bag Firing clip OS VAR ISO & JB Cord 2.8mm ~ 2100mm Vacuum Bag Mesh Sleeve Vac.Bag Painter Line 8mm flat braid per mtr x 3mtr Ocean ISO UL Container ID & Instr. (Old style) Ocean ISO UL Container ID & Instr (New Style) Ocean ISO UL Container "Ocean Safety" Logo x2 Ocean UL "No Step" Label x2 OS ISO Pack Contents Label Container Grommet AquaSpec Service Patch Gist "O" Rings for Hoses x2 Strapping per mtr x 6Mtr Strapping clips x 2 Heat Shrink Seals x2 Bobble Ties OSL0185 x12 <i>Available from December 2020</i>

Section:	Service Spares and Tools			 OCEAN SAFETY®
DATE:	31.10.2020	CREATED BY:	P.Marlow	
ISSUE:	02.2020	CHECKED BY	J.Beaumont	

9. Spare Parts List

9.2.1 ~ Service Items

Service Kits Notes:

The Service kits are designed to allow Service stations to carry out a routine service with the appropriate items.

The Vacuum bag now supplied does not have the hole & gasket to fit the operating head. It has a sleeve for the firing wire to be positioned.

The Firing Wire need to be changed in the Operating Head from the loop firing wire to the twin ball firing wire. This is supplied along with the Vacuum bag firing wire clamp.







There is two metres of line which can be used for the Painter firing lines which needs to be 300mm, the activation cord (800mm) of the liferaft light & securing the paddles.

The labels supplied cover both the original containers & the Mk2 containers.

Part No.	Description	Image	Details
TCS1295	Fluorescent Temporary Tie Fabric Per Meter		Liferaft Temporary Tie Fabric
OSL8080	Container Seal Tape		Post October 2020 Containers are sealed using this tape, instead of the container rubber seal gasket.





Section:	Service Spares and Tools			 OCEAN SAFETY®
DATE:	31.10.2020	CREATED BY:	P.Marlow	
ISSUE:	02.2020	CHECKED BY	J.Beaumont	

9.2.2 ~ Containers Kits, Complete

Part No.	Description	Image	Details
OSL8092	OS ISO 4P <24 Container Mk2		The kit contains: Top & bottom halves of container, Container Grommet, labels & Banding kit
OSL8193	OS ISO 4P >24 & 6P <24 Container Mk2		The kit contains: Top & bottom halves of container, Container Grommet, labels & Banding kit
OSL8194	OS ISO 8P <24 Container Mk2		The kit contains: Top & bottom halves of container, Container Grommet, labels & Banding kit
OSL8195	OS ISO 6P >24 & 8P >24 Container Mk2		The kit contains: Top & bottom halves of container, Container Grommet, labels & Banding kit
OSL8196	OS ISO 10/12 <24 Container, Mk2		The kit contains: Top & bottom halves of container, Container Grommet, labels & Banding kit
OSL8197	OS ISO 10/12P >24 Container, Mk2,		The kit contains: Top & bottom halves of container, Container Grommet, labels & Banding kit











Section:	Service Spares and Tools			
DATE:	31.10.2020	CREATED BY:	P.Marlow	
ISSUE:	02.2020	CHECKED BY	J.Beaumont	OCEAN SAFETY®

9.2.8 ~ Container Kit, Complete

Part No.	Description	Image	Details
Contact Ocean Safety	OS ISO UltraLite Container Mk2 6P Kit, Complete		The kit contains: Top & bottom halves of container, Container Grommet, labels & Banding kit
Contact Ocean Safety	OS ISO UltraLite Container Mk2 8P Kit, Complete		The kit contains: Top & bottom halves of container, Container Grommet, labels & Banding kit
Contact Ocean Safety	OS ISO UltraLite Container Mk2 10P Kit, Complete		The kit contains: Top & bottom halves of container, Container Grommet, labels & Banding kit
Contact Ocean Safety	OS ISO Ultralite Container Mk2 12P Kit Complete		The kit contains: Top & bottom halves of container, Container Grommet, labels & Banding kit







Section:	Service Spares and Tools			 OCEAN SAFETY®
DATE:	31.10.2020	CREATED BY:	P.Marlow	
ISSUE:	02.2020	CHECKED BY	J.Beaumont	

9.2.3 ~ Valves

Part No.	Description	Image	Details
OSL0125	OS ISO GIST Inlet Valve 1.2 Jet		
OSL0150	OS-VAR A6 Relief Valve Brown		Component part for 4 & 6 person liferaft only. Pre December 2010
OSL0160	OS-VAR A10B Relief Valve		Component part for 8, 10 & 12 person liferaft only. Pre December 2010
OSL0165	B10 PRV - Brown		Post 2010 Under the cap, there is a label with the batch number. It also has a coloured dot, this should be "Brown".
OSL0168	A8 - Top Up Valve		
OSL0170	OS-VAR A6 Relief Valve Bung		
OSL0175	OS-VAR A 10 Relief Valve Bung		
OSL0177	OS-VAR B10 Relief Valve Bung		
OSL0190	OS ISO Airflow Transfer Valve		0.5 psi Pre June 2011
OSL0195	OS ISO Airflow Top Up Valve		0.5 psi Post June 2011

Section:	Service Spares and Tools			 OCEAN SAFETY®
DATE:	31.10.2020	CREATED BY:	P.Marlow	
ISSUE:	02.2020	CHECKED BY	J.Beaumont	

9.2.4 ~ Inflation Systems

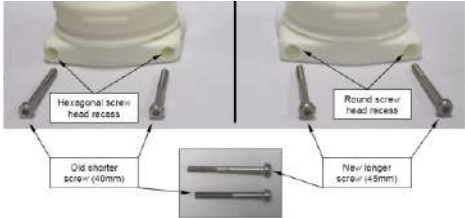
Part No.	Description	Image	Details
CYL2116	OS ISO GIS Disc Plug 400 Bar (Air)		Leaffield Part ~ 0907002
CYL2320	GIS Cylinder Valve Complete		Made up of the following components: 21LB LR Syl, Refill & P/Test GIS Valve Transit Safety Plug Leaffield Recoil Cap GIS Cutter
CYL2380	GIS Operating Head Firing Wire		30mm sleeve
CYL2385	OS ISO GIS Operating Head O-Ring		Leaffield Part ~ 66300458
CYL2390	OS ISO GIS Cutter		Penetrator assembly Complete with O-Ring seal
OSL0102	OS-ISO GIST Operating Head O-Ring		
OSL0104	GIST Operating Head Assembly 'Twin Ball'		<p>The earlier White Operating Heads had shorter screw 40mm with hexagonal screw recess heads. The new White Operating Heads have Round Screw head recess, supplied with two 45mm screws.</p> <p>Only use the correct length screw, with the right operating head.</p> 

Section:	Service Spares and Tools			
DATE:	31.10.2020	CREATED BY:	P.Marlow	
ISSUE:	02.2020	CHECKED BY	J.Beaumont	OCEAN SAFETY®

9.2.4 ~ Inflation Systems

Part No.	Description	Image	Details
OSL0105	Torque Drive Assembly		
OSL0107	GIST Firing Wire Long Twin Ball		This has replaced OSL0103 Length 145mm
OSL0110	GIST Break Stem 250 Bar		All new Break Stems have a notch, also marked with a batch number. Max. safe pressure at 65deg C - 190 Colour code ~ white
OSL0115	GIST Cylinder Valve Assembly - 250 Bar		
OSL0513	OS-VAR Vacuum Bag Firing Line Clip		
OSL0125	M16 Quick Fit Connector		
OSL0130	OS ISO GIST 546mm Hose c/w Connector		c/w OSL0125 ~ M16 Quick Fit Connector.
OSL0135	OS ISO GIST 546mm Hose		

Section:	Service Spares and Tools			 OCEAN SAFETY®
DATE:	31.10.2020	CREATED BY:	P.Marlow	
ISSUE:	02.2020	CHECKED BY	J.Beaumont	

9.2.4 ~ Inflation Systems

Part No.	Description	Image	Details
OSL0137	GIST "O" Ring for Hose & Fill Bung		
OSL0140	GIST Valve Assembly (M18) 450 Bar		c/w Blast Disc & Penetrator
OSL0142	OS-ISO GIS Operating Head		c/w Vac Bag securing nut
OSL0143	OS ISO GIS Port Adaptor		3/8" BSP to M16 x 2
OSL0400	OS ISO Painter Line Assembly		Painter Line 10.8 meter of 8mm Flat braid c/w Painter Pocket



Section:	Service Spares and Tools			 OCEAN SAFETY®
DATE:	31.10.2020	CREATED BY:	P.Marlow	
ISSUE:	02.2020	CHECKED BY	J.Beaumont	

9.2.4 ~ Inflation System





Part No.	Description	Image	Details
OSL0010	OS ISO 4P Liferaft Cylinder		2.5 Ltr cylinder c/w GIST Cylinder valve Assembly
OSL0012	OS ISO 6 & 8P Liferaft Cylinder		5 Ltr cylinder c/w GIST Cylinder valve Assembly
OSL0014	OS ISO 10 & 12P Liferaft Cylinder		7.5 Ltr cylinder c/w GIST Cylinder valve Assembly
OSL0071	OS ISO UltraLite 6P & 8P 4.7Ltr Cylinder		GIS Valve Assembly (M18) 450bar OS ISO GIS Port Adaptor Cylinder - Carbon Composite - 4.7Ltr GIS Valve Penetrator Assembly OS ISO GIS Disc Plug 400 Bar (Air)
OSL0072	OS ISO UltraLite 10P 6 Ltr Cylinder		GIS Valve Assembly (M18) 450bar OS ISO GIS Port Adaptor Cylinder - Carbon Composite - 6.0Ltr GIS Valve Penetrator Assembly OS ISO GIS Disc Plug 400 Bar (Air)
OSL0053	OS ISO UltraLite 12P 6.8Ltr Cylinder		GIS Valve Assembly (M18) 450bar OS ISO GIS Port Adaptor Cylinder - Carbon Composite - 6.8Ltr GIS Valve Penetrator Assembly Thanner Disc Plug Air/N2 (G)

Section:	Service Spares and Tools			 OCEAN SAFETY®
DATE:	31.10.2020	CREATED BY:	P.Marlow	
ISSUE:	02.2020	CHECKED BY	J.Beaumont	

9.2.5 ~ Light System

Part No.	Description	Image	Details
OSS0072	Aquaspec Liferaft Light AQLRL		Internal / External Light & Battery From September 2020 this will be the Liferaft light fitted to all Ocean Safety liferafts.
OSS0073	AquaSpec LR Lt Service patch		

9.2.6 ~ Repairs

Part No.	Description	Image	Details
OSL8550	Adhesive Bostik 2402 + Hardener		4.8 Ltr Tin (A/B Part)
OSL8800	OS ISO Buoyancy Fabric (per m ²)		
OSL8805	OS ISO Canopy Fabric (per m ²)		
OSL8870	Cord 3mm (per M)		Used for connecting the component parts of the Liferaft
OSL8875	Cord 1.2mm (per M)		Used for connecting the component parts of the Liferaft



Section:	Service Spares and Tools			 OCEAN SAFETY®
DATE:	31.10.2020	CREATED BY:	P.Marlow	
ISSUE:	02.2020	CHECKED BY	J.Beaumont	

9.2.7 ~ Emergency Equipment

Part No.	Description	Image	Details
FLR5000	Parachute Rocket Flares MCA		Direct Replacement
FLR5005	Red Hand Held Flares MCA		Direct Replacement
FLR5010	Orange Buoyant Smoke MCA		Direct Replacement
MED0090	SOLAS First Aid Kit		For vessels outside the EU
MED0100	First Aid Kit Cat - C		Direct Replacement
MED0115	ISAF First Aid Kit		







Section:	Service Spares and Tools			 OCEAN SAFETY®
DATE:	31.10.2020	CREATED BY:	P.Marlow	
ISSUE:	02.2020	CHECKED BY	J.Beaumont	

9.2.7 ~ Emergency Equipment

	Details		Part Number
OSL0230	OS ISO Quoit & Line		c/w pouch
OSL0265	OS ISO Paddles		Supplied in a plastic bag & should remain in the bag when packing into liferaft.
OSL0275	OS ISO Torch, Batteries & Spare Bulb		
OSL0280	OS ISO Owners Instructions & Cert.		Complies with ISO 9560 Part One - Liferaft standard equipment.
OSL0310	OS ISO Equipment Bag		
OSL0315	OS ISO Bailer		
OSL0330	OS ISO Clam Seals		





Section:	Service Spares and Tools			 OCEAN SAFETY®
DATE:	31.10.2020	CREATED BY:	P.Marlow	
ISSUE:	02.2020	CHECKED BY	J.Beaumont	

9.2.7 ~ Emergency Equipment cont.

Part No.	Description	Image	Details
OSL0345	OS ISO Pump		Supplied with Adapter OSL0320 required to connect to top up valve
OSL0345	OS ISO A8 Pump Adapter		
SUR0005	Sea Sickness Tablets		6 per person, container holds 60 tablers
SUR0015	Waterproof Torch c/w Spare Bulb		
SUR0030	Signal Mirror		4" Heliograph Mirror - MCA
SUR0035	Food Rations		10,000 kj per person, >24 hour pack only
SUR0035	Water Rations		1 1/2 Litre water Sachets, per person, >24 hour pack only

Section:	Service Spares and Tools			 OCEAN SAFETY®
DATE:	31.10.2020	CREATED BY:	P.Marlow	
ISSUE:	02.2020	CHECKED BY	J.Beaumont	

9.2.7 ~ Emergency Equipment cont.

Part No.	Describe	Image	Details
SUR0076	Safety Knife		
SUR0090	Compressed Sponge		
SUR0115	Inflatable Radar Reflector		SOLAS B Pack only
SUR0125	Drogue & Line		
SUR0135	Heaving Line c/w Quoit		
SUR0140	Thermal Protective Aid - MCA		>24 hour pack & SOLAS B Pack
SUR0160	SOLAS No.2 Card		SOLAS B Pack only
SUR0165	Whistle		
SUR0180	Sea Sickness Bags		Re-sealable bags, 1 per person

Section:	Service Spares and Tools			
DATE:	31.10.2020	CREATED BY:	P.Marlow	
ISSUE:	02.2020	CHECKED BY	J.Beaumont	OCEAN SAFETY®

9.2.8 ~ Containers

Part No.	Description	Image	Details
OSL8086	OS ISO 4P <24 Container Mk2 Bottom Half		4 Person <24 Hour Bottom Half
OSL8087	OS ISO 4P <24 Container Mk2 Top Half		4 Person <24 Hour Top Half
OSL8088	OS ISO 4P >24 & 6P <24 Container Mk2 Bottom Half		4 Person >24 hour & SOLAS B Pack 6 Person <24 hour Bottom half
OSL8089	OS ISO 4P >24 & 6P <24 Container Mk2 Top Half		4 Person >24 hour & SOLAS B Pack 6 Person <24 hour Top half
OSL8090	OS ISO 8P <24 Container Mk2 Bottom Half		8 Person <24 Hour Bottom Half
OSL8091	OS ISO 8P <24 Container Mk2 Top Half		8 Person <24 Hour Top Half
OSL8092	OS ISO 6P >24 & 8P >24 Container Mk2 Bottom Half		6 Person >24 hour & SOLAS B Pack 8 Person >24 hour & SOLAS B Pack Bottom Half
OSL8093	OS ISO 6P >24 & 8P >24 Container Mk2 Top Half		6 Person >24 hour & SOLAS B Pack 8 Person >24 hour & SOLAS B Pack Top Half

Section:	Service Spares and Tools			
DATE:	31.10.2020	CREATED BY:	P.Marlow	
ISSUE:	02.2020	CHECKED BY	J.Beaumont	OCEAN SAFETY®

9.2.8 ~ Containers

Part No.	Description	Image	Details
OSL8094	OS ISO 10/12 <24 Container, Mk2 Bottom Half		10/12 Person <24 Hour Bottom Half
OSL8095	OS ISO 10/12 <24 Container, Mk2 Top Half		10/12 Person <24 Hour Top Half
OSL8096	OS ISO 10/12P >24 Container, Mk2 Bottom Half		10/12 Person >24 hour & SOLAS B Pack Bottom Half
OSL8097	OS ISO 10/12P >24 Container, Mk2, Top Half		10/12 Person >24 hour & SOLAS B Pack Top Half

Section:	Service Spares and Tools			
DATE:	31.10.2020	CREATED BY:	P.Marlow	
ISSUE:	02.2020	CHECKED BY	J.Beaumont	OCEAN SAFETY®

9.2.8 ~ Containers

Part No.	Description	Image	Details
Contact Ocean Safety	OS ISO UltraLite Container Mk2 ~ 6 Person Bottom Half		OS ISO UltraLite Container Mk2 ~ 6 Person, Black Carbon Bottom Half
Contact Ocean Safety	OS ISO UltraLite Container Mk2 ~ 6 Person Top Half		OS ISO UltraLite Container Mk2 ~ 6 Person, Black Carbon Top Half
Contact Ocean Safety	OS ISO UltraLite Container Mk2 ~ 8 Person Bottom Half		OS ISO UltraLite Container Mk2 ~ 8 Person, Black Carbon Bottom Half
Contact Ocean Safety	OS ISO UltraLite Container Mk2 ~ 8 Person Top Half		OS ISO UltraLite Container Mk2 ~ 8 Person, Black Carbon Top Half
Contact Ocean Safety	OS ISO UltraLite Container Mk2 ~ 10 Person Bottom Half		OS ISO UltraLite Container Mk2 ~ 10 Person, Balck Carbon Bottom Half
Contact Ocean Safety	OS ISO UltraLite Container Mk2 ~ 10 Person Top Half		OS ISO UltraLite Container Mk2 ~ 10 Person, Black Carbon Top Half
Contact Ocean Safety	OS ISO Ultralite Container Mk2 ~ 12 Person Bottom Half		OS ISO Ultralite Container Mk2 ~ 12 Person, Black Carbon Bottom Half
Contact Ocean Safety	OS ISO Ultralite Container Mk2 ~ 12 Person Top Half		OS ISO Ultralite Container Mk2 ~ 12 Person, Black Carbon Top Half

Section:	Service Spares and Tools			 OCEAN SAFETY®
DATE:	31.10.2020	CREATED BY:	P.Marlow	
ISSUE:	02.2020	CHECKED BY	J.Beaumont	





9.2.8 ~ Valise

Part No.	Description	Image	Details
OSL8100	OS ISO 4 Person, Valise		Size 670 x 450 x 270
OSL8102	OS ISO 6/8 Person, Valise		Size 740 x 470 x 290
OSL8103	OS ISO 10 Person, Valise		Size 850 x 450 290
OSL8110	OS ISO UltraLite 6/8 Person Valise		760 x 450 x 260
OSL8115	OS ISO UltraLite 10/12 Person Valise		860 x 450 x 270

Section:	Service Spares and Tools			 OCEAN SAFETY®
DATE:	31.10.2020	CREATED BY:	P.Marlow	
ISSUE:	02.2020	CHECKED BY	J.Beaumont	

9.3 ~ Tools

9.3.1 ~ GIST Tools

Part No	Description	Image	Details
OSL9500	GIST Filling Tool		
OSL9502	GIST Had Re-Setting Tool		
OSL9503	GIST Recoil Cap		
OSL9504	GIST Dust Cap		
OSL9510	GIST Inlet Valve Spanner		



Section:	Service Spares and Tools			 OCEAN SAFETY®
DATE:	31.10.2020	CREATED BY:	P.Marlow	
ISSUE:	02.2020	CHECKED BY	J.Beaumont	

9.3.2 ~ GIS Tools

Part No	Description	Image	Details
CYL2360	GIS Valve Transit Safety Plug		
OSL9550	GIS Cylinder Valve Filling Tool		
OSL9551	GIS Operating Head Re-setting Tool		
OSL9552	GIS Plug Gauge		
OSL9553	Ultralite Filling Adaptor 300 Bar		

Section:	Service Spares and Tools			 OCEAN SAFETY®
DATE:	31.10.2020	CREATED BY:	P.Marlow	
ISSUE:	02.2020	CHECKED BY	J.Beaumont	

9.3.2 ~ Tools, Various

Part No.	Description	Image	Details
OSL9514	B10 Installation Spanner		
OSL9517	D7, C7, A6 Spanner		
OSL9525	Banding Tensioner		
OSL9526	Banding Closing Tong		
OSL9535	A8 Testing/ Deflating Adaptor		
OSL9540	Ocean ISO Inflation Adaptor - Saganaw		
OSL9555	Bonning Tool		
OSL9556	Swedish Fid		