

FIGARO

an ISO9001 company

Application Notes for CO Detectors using TGS5xxx Series

Figaro’s TGS5xxx series electrochemical CO sensors are suitable for residential CO detectors and fire detectors, and are widely used throughout the world. This document includes important technical advice for designing and manufacturing the devices using TGS5xxx sensors. Please read carefully before designing devices using these CO sensors.



Page

Basic Characteristics.....2

Circuit Design

Circuit Example.....2

Setting Reference Voltage.....3

Voltage Follower.....3

Anti-polarization Circuit.....3

Current/Voltage Conversion Circuit.....3

Amplification Factor (gain).....3

Operational Amplifier (Op-Amp).....4

Electric Noise Prevention.....4

Technique for Passing 5000ppm CO Exposure Test.....4

Self Diagnosis Circuit.....4

Compensation of Long-Term Drift.....7

PCB and Housing Design

Position Dependency of the Sensor.....8

Thermistor Location.....8

Housing Design for Quick Response.....8

Packaging Design.....8

Calibration

Calibration Using CO Gas.....8

Calibration Using Individual Sensor Data.....9

Temperature Compensation.....9

Calculation of CO Concentration.....9

Manufacturing Process

Handling and Storage of Sensors.....9

PCB Assembly.....10

Sensor Assembly.....10

Final Assembly.....10

Gas Test.....10

Storage of Finished Products.....10

Packaging.....11

Quality Control.....11

Frequently Asked Questions.....11

Appendix 1 - Sensor Marking.....13

Appendix 2 - Temperature Compensation Coefficients for Residential Usage.....14

Appendix 3 - Temperature Compensation Coefficients for Portable Generators.....15

IMPORTANT NOTE: OPERATING CONDITIONS IN WHICH FIGARO SENSORS ARE USED WILL VARY WITH EACH CUSTOMER’S SPECIFIC APPLICATIONS. FIGARO STRONGLY RECOMMENDS CONSULTING ITS TECHNICAL STAFF BEFORE DEPLOYING FIGARO SENSORS IN YOUR APPLICATION AND, IN PARTICULAR, WHEN CUSTOMER’S TARGET GASES ARE NOT LISTED HEREIN. FIGARO CANNOT ASSUME ANY RESPONSIBILITY FOR ANY USE OF ITS SENSORS IN A PRODUCT OR APPLICATION FOR WHICH THE SENSOR HAS NOT BEEN SPECIFICALLY TESTED BY FIGARO.



TGS5042 and TGS5141 are a UL recognized components in accordance with the requirements of UL2034. Please note that component recognition testing has confirmed long term stability in 15ppm of CO; other characteristics shown in this brochure have not been confirmed by UL as part of component recognition.

This document is mainly designed to address residential CO detector applications. However, these design concepts can be applied to CO detectors for Recreational Vehicles (RVs) and fire alarms/detectors as well.

1. Basic Characteristics

This document covers Figaro electrochemical CO sensors TGS5042 and TGS5141. Expected sensor life of these models is 10 years or longer. Please refer to Table 1 for a summary of the basic differences among these sensors. Accordingly, TGS5042 is most suitable for accuracy-oriented devices, while TGS5141 is best suited for size-oriented devices.

TGS5xxx series sensors are fuel cell type electrochemical sensors with two electrodes. Sensor output current changes linearly with CO concentration. To use the sensor for CO detection, sensor current should be converted to output voltage using an Op-Amp.

	TGS5042	TGS5141
Size	Large	Compact
Expected sensor life	10 yrs+	10 yrs+
Humidity dependency	no	yes (within±10%)
Water reservoir	yes	no

Table 1 - Sensor model comparison

2. Circuit Design

2-1 Circuit diagram

Fig.1 shows an example circuit for CO detectors with the following conditions:

Power source: Battery

Driving voltage: 2.5V

Using this circuit, sensor output current can be converted to output voltage (V_{out}). In this circuit, V_{out} at 0ppm CO is typically set at 2.0V (V_{ref}), and V_{out} will decrease as CO concentration increases. By measuring the output voltage decrease, CO concentration can be calculated. To make a circuit in which V_{out} increases as CO concentration increases, an inverting amplifier circuit should be added.

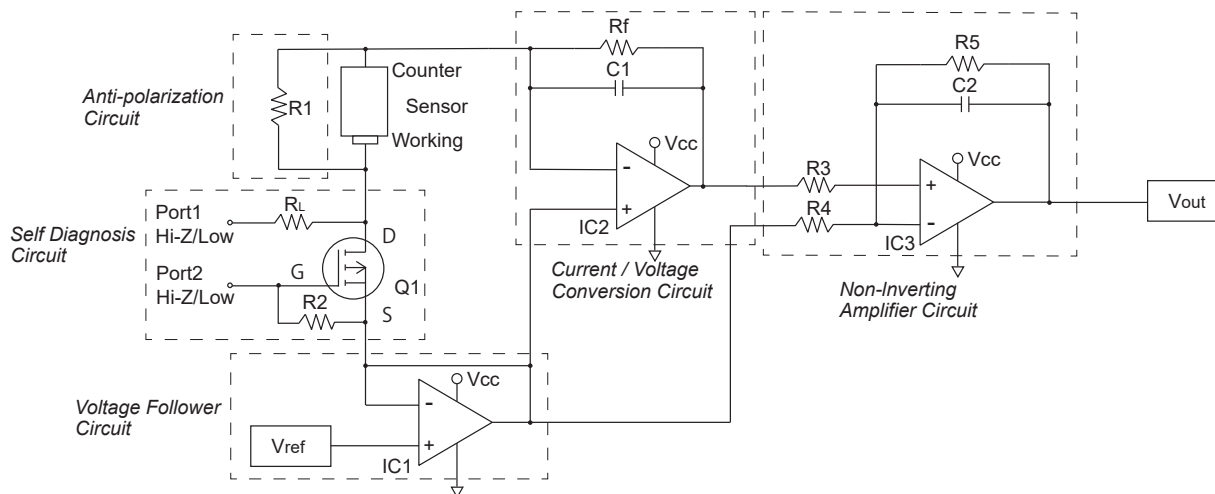

Figure 1 - Example circuit for TGS5xxx sensors

2-2 Setting reference voltage (V_{ref})

Since the Op-Amp used for converting sensor current to output voltage may have an offset voltage that is less than 0V, it is possible for V_{out} to be less than 0V if V_{ref} would be set at 0V. Therefore, it is necessary to set V_{ref} at a value higher than the absolute value of the offset voltage. In this example circuit, the reference voltage is set at 2V.

Although higher reference voltage increases signal resolution for CO detection, when using a battery to power the circuit, V_{ref} should be less than the cut-off voltage of the battery (i.e. the lower-limit voltage at which battery discharge is considered complete). This should be considered as the upper limit of V_{ref} .

2-3 Voltage follower circuit

To prevent the possibility of V_{ref} being influenced by other parts of the overall circuit, Voltage follower plays a role to keep V_{ref} stable as well as to convert impedance of reference voltage.

2-4 Anti-polarization circuit

When stored in an open circuit condition (i.e., no connection between the working electrode and the counter electrode), an electrical charge will accumulate on the electrodes. This effect is called polarization. Since sensors are shipped and stored in an open circuit condition, an anti-polarization circuit as shown in Fig. 1 (using a fixed resistor R1) is recommended to allow the electrodes to discharge so that the sensor output will stabilize. Please note that the smaller the resistor value, the larger the offset voltage. The larger the resistor value, the longer the output stabilization time.

Instead of using the anti-polarization circuit shown in Fig.1, a JFET can be used for anti-polarization. While a JFET is less cost effective, it takes a shorter time to discharge the sensor. Since stabilization time depends on the level of polarization, it is recommended to check stabilization time in the user's actual circuit under actual environment conditions.

2-5 Current/Voltage conversion circuit

Sensor current output is converted into voltage as

shown in Fig.1. V_{out} is expressed by the following formula:

$$V_{out} = V_{ref} - I_s \times R_f + V_{offset}$$

I_s : sensor current

R_f : feedback resistor

V_{offset} : offset voltage of Op-Amp

2-6 Amplification factor (gain)

Since the sensor's output current is very small, in order to achieve sufficient resolution for converting to output voltage, the current should be amplified by an Op-Amp.

The required amplification gain is determined by selecting V_{cc} , and a microprocessor in terms of sensor output range, target gas concentration, and required accuracy. The formula for determining gain is as follows:

$$\text{Gain} = (V_{ref} - V_{max}) / (I_{max} \times T \times C_{max})$$

where:

V_{ref} = voltage at 0ppm

V_{max} = voltage at C_{max}

I_{max} = max. sensitivity to CO (nA/ppm)

T = Temp dependency coefficient [$I(50^\circ\text{C})/I(20^\circ\text{C})$]

C_{max} = upper limit of CO detection range (ppm)

Please refer to Appendix 2 for temperature dependency coefficients for each sensor model.

The following is an example of how to decide amplification gain. In the following circuit conditions, it is calculated to set 520k or higher gain:

V_{cc} : 2.5V

Microprocessor: 10 bit

Minimum required number of bits: 4 bits

Detection range: 0~1,000ppm CO

Full scale: 1,000ppm CO

Sensor output at 0ppm CO: +2V

Sensor output at 1,000ppm CO (V_{max}): 0V

Max. sensor current of TGS5141 (I_{max}): 3.2nA/ppm

Temperature dependency of TGS5141:

$$I(50^\circ\text{C})/I(20^\circ\text{C}) = 1.225 \text{ (refer to Sec 6-3)}$$

$$\text{Gain} = (2.0\text{V} - 0\text{V}) / (3.2\text{nA} \times 1.2 \times 1,000\text{ppm}) = 520\text{k}$$

In case the minimum required is 4 bits, resolution will be 3.9ppm.

$$\text{Resolution} = C_{\text{max}} / 2^M \times B_{\text{min}}$$

where:

C_{max} = maximum target CO concentration

M = Number of bits in microprocessor

B_{min} = Minimum number of bits required

$$1000\text{ppm} / 2^{10} \times 4 = 3.9\text{ppm}$$

With 520k or higher amplification gain, enough signal resolution can be obtained to pass EN50291 (i.e. to distinguish between 36ppm and 50ppm).

2-7 Operational amplifier (Op-Amp)

A rail to rail Op-Amp is recommended for usage. Depending on the balance among power consumption, accuracy, and electric noise, a suitable Op-Amp for devices should be selected. The following Op-Amps are recommended by Figaro: MCP6042, MCP617 (Microchip), TSV914 (STMicroelectronics).

2-8 Electrical noise prevention

Since sensor current is very small and amplification gain is large, the sensor is easily influenced by external electrical noise. As a result, it is necessary to implement measures to minimize electrical noise in the circuit pattern, power supply, etc.

There are three options as a countermeasure for electrical noise:

- 1) Use an electric noise filter
- 2) Use a voltage follower circuit
- 3) Use an RC circuit for power input, output, and amplification of the Op-Amp.

Specifically, by increasing the values of C1 in Fig.1, influence by electric noise can be reduced. However, response speed will become slower as C1 increases, so it is necessary to decide the C1 value considering the balance between electric noise levels and response speed.

If incoming noise is too large to be prevented by the above measures, additional countermeasures can be taken:

- * Use a microwave absorber sheet
- * Protect metallic shielding over the electronic circuit

2-9 Technique for passing 5000ppm CO exposure test

Most electrochemical CO sensors have long recovery time after exposure to high CO gas concentration. As a result, detectors using them cannot pass the 5000ppm CO exposure test of EN50291 (5.3.6) without some countermeasure. When amplified sensor output drops to GND level and does not change after exposure to 5,000ppm CO, sensor output in air will show a lower voltage than V_{ref} for a while (this phenomenon is referred to as ‘undershoot’). As a result, output voltage in CO will temporarily decrease, resulting in non-conformity to EN50291.

As a countermeasure to undershoot, two methods can be suggested:

1. Amplify by two steps

The first amplification gain: A feedback resistor (R_f) is selected so that output voltage from the Op-Amp in 5000ppm of CO does not drop to GND level. The second amplification gain is set to have enough signal resolution.

2. Switch amplification gain depending on sensor output (see Fig. 2)

2-10 Self diagnosis circuit

Self-diagnosis is a safety measure required by the UL2034 standard to detect a sensor malfunction. Figaro’s self-diagnostic circuit checks for malfunction in the 5xxx-series sensors by using the sensor’s capacitance. The sensor will be charged by an external power supply as soon as it is disconnected from the amplifier circuit. Any malfunction of the sensor can be assessed by analyzing the subsequent discharge pattern from the sensor.

Sensitivity to CO can be lost due to wire breakage or short circuit. This type of malfunction can be detected by the self-diagnostic circuit. On the other hand, this test method cannot detect loss of CO sensitivity due to lack of gas diffusion inside the sensor if dust or water droplets cover the pin hole for gas diffusion, or if the sensor’s water reservoir (if any) dries up. In addition, a slight loss of CO sensitivity cannot be detected by the self-diagnosis test. The self-diagnosis is designed to detect serious CO sensor failure.

Figs. 3, 4, and 5 show examples of the self-diagnostic circuit, self-diagnosis process chart, and the Vout patterns corresponding to each condition of the sensor respectively.

Precautions for designing a circuit

Depending on the resistance values of Rf and RL, the negative feedback control of the op-amp may not work correctly during the process 2, resulting in a voltage being applied directly to the sensor, which may damage the sensor performance. To avoid such damage to sensor performance, it is necessary to carefully select Vref, Vc and Rf values that satisfy the following equation:

$$V_{ref}/R_L < (V_{cc} - V_{ref}) / R_f$$

The basic steps of self-diagnosis are:

Process 1) *Disconnect the sensor temporarily from the circuit and apply an electrical charge to the sensor*
 Set Port1 to Low and Port2 to Hi-Z so that the connection between the drain and the source is open and the sensor is charged for a certain period of time. Please choose the current value and the duration of the current flow so that the accumulated electric charge does not to exceed 10μC (e.g. @1 μA for 10 sec.) :

(Electric charge = Current x Current flow period)

Process 2) *Reconnect the sensor to the circuit*

At the end of Process 1, switch the Port1 to Hi-Z and the Port2 to Low to short-circuit the drain and source and reconnect the sensor to the circuit. This will discharge the electric charge on the sensor.

Process 3) *Self-diagnosis determination is carried out*

By measuring the output voltage (Vout) after reconnecting the sensor to the circuit, self-diagnosis determination can be carried out. By observing Vout, the circuit can distinguish between normal sensors and abnormal sensors as follows:

Normal sensors:

Vout drops below 1.5V and returns to its initial level (Vref) after the electrical charge on the sensor has been discharged.

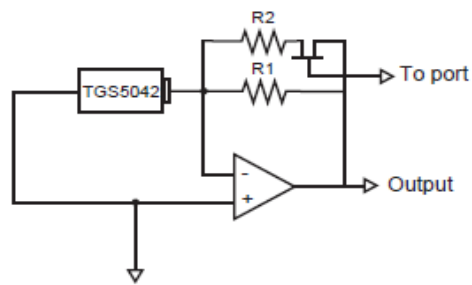

Figure 2 - Circuit for changing gain using a FET

Open sensors:

Vout is at a similar level to the initial level (Vref) since no electric charge is applied on the open sensors in Process 1.

open sensors: $V_{out} \approx V_{ref}$

Short sensors:

short sensors: $V_{out} > V_{ref}$

$$V_{offset} = (1 + R_f/R_s) + R_f \times I_s$$

Rs: Sensor resistance

When the sensor is short-circuited, Rs becomes very small, resulting in a large Voffset.

Vout in Process 1) is expressed by the following formula:

$$V_{out} = I_s \times R_f + V_{offset}$$

Therefore, Vout will also be greater than Vref.

Please note that the above Vout level is based on the circuit shown in Fig.1.

Since the judgement level depends on the circuit design, please set it according to the customer's actual circuit.

Vout will return to its initial level about one minute after the sensor judgment in Process 3. Please note that the greater the electrical charge on the sensor, the longer it takes to complete the self-diagnosis. If the electrical charge builds up on the sensor before Vout returns to its initial level (Vref), the sensor may be damaged.

Recommended circuit

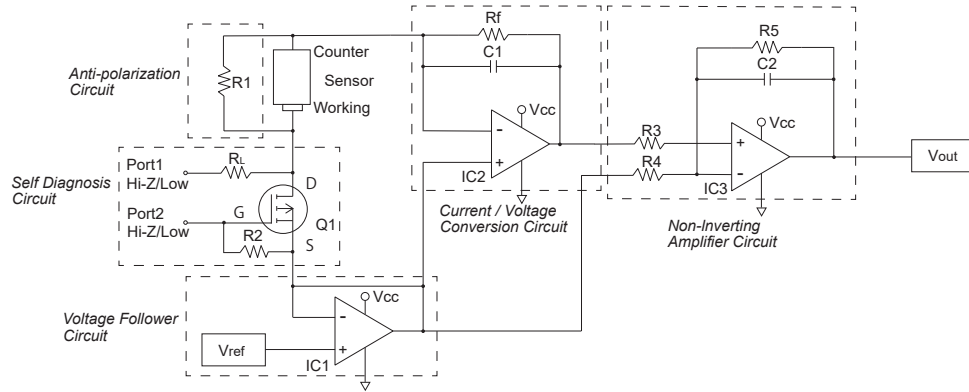

Nomal operation mode and Process 2

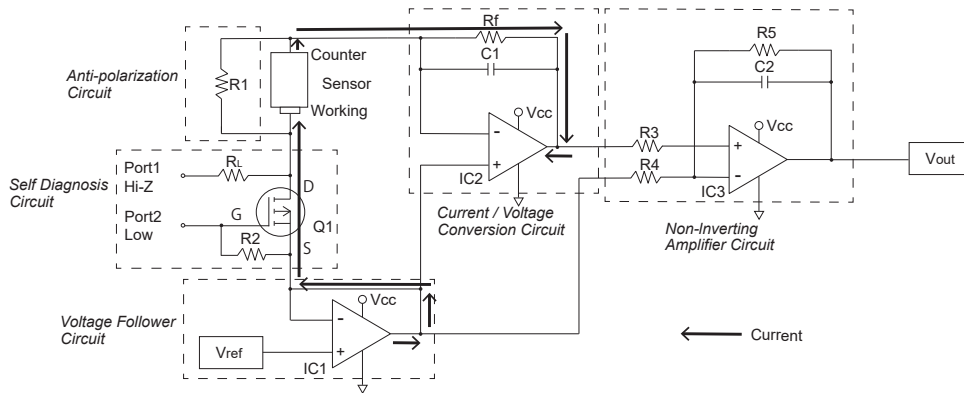

Process 1

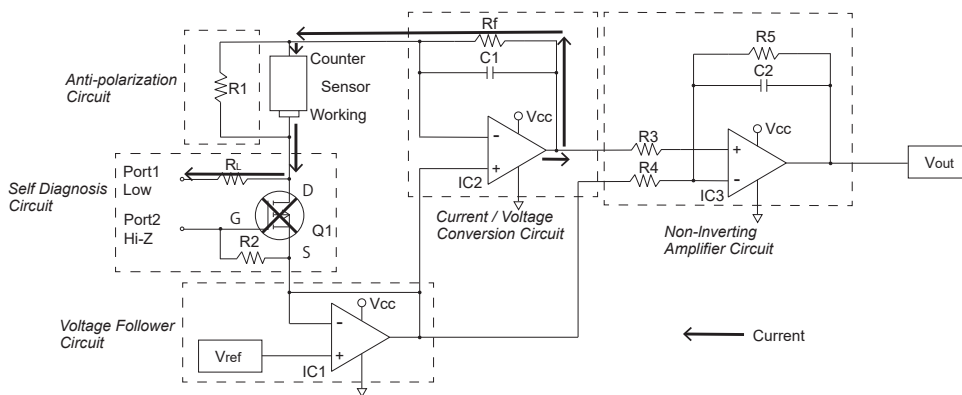

Figure 3 - Self-diagnostic circuit

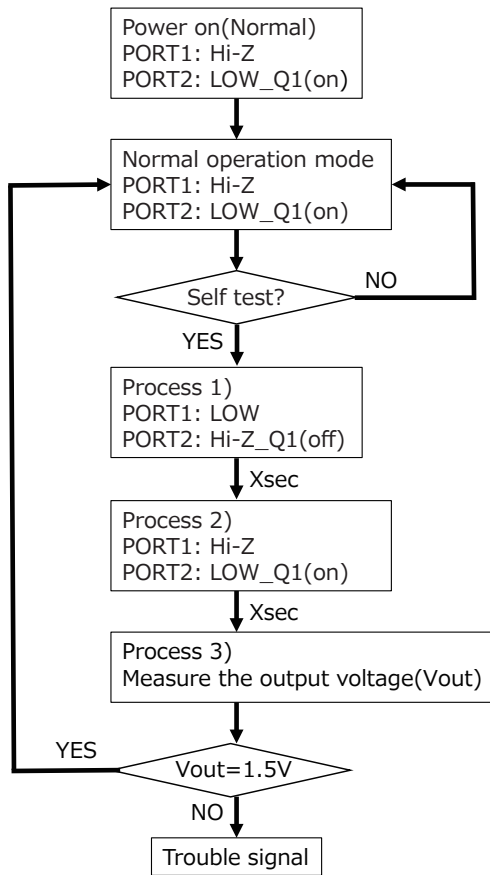

Figure 4 - Self-diagnosis flow chart

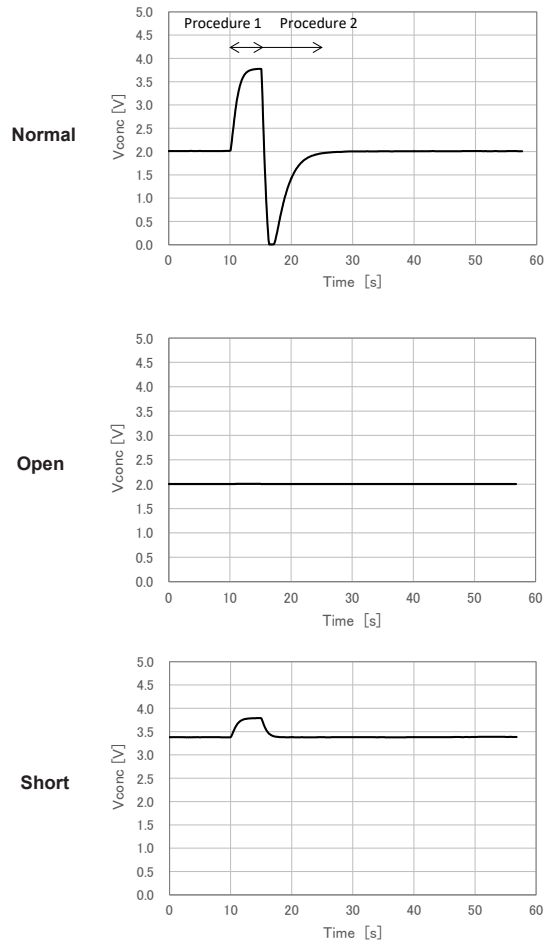

Figure 5 - Vout response patterns for self-diagnosis

Note:

Users should conduct a verification test using their actual circuit.

Do not perform the self-diagnosis test in the presence of CO gas. The self-diagnosis test should be carried out while in clean air.

3. Compensation of Long Term Drift

Fig. 6 shows typical long term stability data. In general, electrochemical CO sensors tend to show decreased sensitivity over time. For CO detectors requiring higher accuracy, it is recommended to adjust CO concentration readings by an increment of 2% per year for compensating long term drift for both TGS5042 and TGS5141. Please consult Figaro for further details.

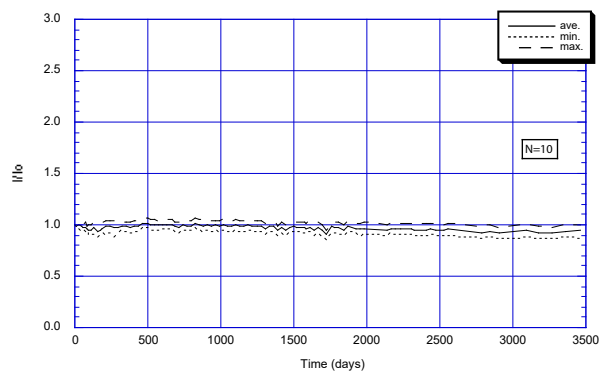

Figure 6 - Typical long term stability of TGS5042

4. PCB and Housing Design

4-1 Position dependency of the sensor

TGS5141 has no position dependency since the sensor does not have any liquid inside. On the other hand, TGS5042 has a water reservoir. While this sensor has no position dependency in normal usage such as in residential CO detectors, for applications where ambient temperature can change drastically and suddenly to less than -20°C, it is recommended that the sensor should be placed in a vertical position with the working electrode upward. If the sensor is positioned horizontally or vertically with the working electrode down, the sensor may be structurally damaged by large volume expansion in case the water in the reservoir freezes quickly.

4-2 Thermistor location

A thermistor should be located as near to the sensor as possible in order to accurately measure ambient temperature around the sensor.

4-3 Housing design for quick response

For applications where quick response is required, such as simple CO analyzers, the gas inlet of the sensor should be located at the detector slit/opening. A small compartment with slits in at least two sides to promote airflow is also recommended. Refer to Fig. 7 for an example of suggested housing design.

5. Packaging Design

The sensor may be susceptible to poisoning by out-gas from packing materials. For example, certain printing inks and insufficiently cured plastics may emit vapors that could adversely affect sensitivity. Be sure that all printing inks and plastics (especially styrene) are completely cured prior to usage. In addition, since dew condensation may take place inside the TGS5042 sensor, inhibiting its ability to sense CO, it is recommended that any bag in which the detector is placed should NOT be sealed. Ideally, packages should be designed so that ambient air can diffuse into the detectors. As an additional precaution, a charcoal bag may be placed inside packaging

1) Sensor compartment



2) Slits



Figure 7 - Sensor compartment design

materials to protect from the effects of out-gassing from packaging materials.

A storage test should be conducted with final packaging by the detector maker to determine if the sensor is damaged/influenced by packaging.

6. Calibration

6-1 Calibration Using CO Gas

- 1) After powering the circuit, wait 5 minutes to stabilize sensor output in clean air
- 2) Perform the zero adjustment process by measuring sensor output in clean air (V0) (*see Note 1 below*)
- 3) Inject C1ppm of CO gas
where: C1 = target concentration of CO
- 4) After stabilizing sensor output (e.g. 3~4 min), measure sensor output (V1)
- 5) Calculate sensor sensitivity α from V0, V1, and feedback resistor (Rf):

$$\alpha = (V0 - V1) / (C1 \times Rf) \quad [\text{Equation A}]$$

Using this method, accuracy of $\pm 5\%$ can be obtained for display readings. Please note that temperature should be in the range of $20^\circ\text{C} \pm 2^\circ\text{C}$ during the calibration process since the sensor has dependency on temperature.

Note 1: If CO gas is present during the zero adjustment process, a correct zero adjustment cannot be carried out. A detector should be checked in advance to verify that it generates output corresponding to a CO concentration less than 10ppm after subtracting detector output without sensor.

6-2 Calibration using sensor barcode data

Using individual data printed on sensor, which is measured at Figaro's factory before shipping, can considerably simplify the calibration process. Though the expected accuracy is less than that for calibrating with CO gas, this method can achieve significant reduction in handling costs while achieving acceptable accuracy. Subject to adjustment due to variation in environmental conditions, on average, calibration using barcode data would yield accuracy of approx. $\pm 15\%$.

* For TGS5141 to comply with EN50291, calibration using CO gas is recommended instead of calibration using sensor barcode data.

6-2-1 Sensor Marking

The barcode shown on the sensor body (see Appendix I) contains the following individual sensor data:

One dimensional bar code:

xxxx

Two-dimensional barcode:

xxxxxxxxxxxxxxxxxxxxxxxxxxxxxxxx

where:

xxxx = sensor's sensitivity (slope) numeric value calculated by the equation A (e.g. 1827=1.827nA/ppm)

6-2-2 Input sensitivity data into microprocessor

Sensor data from the label can be read into the microprocessor in one of two ways:

- 1) Manually input the user readable value printed on the sensor body.
- 2) Using a barcode reader (see Appendix I), read the barcode and input directly to the microprocessor.

6-2-3 Compensation of offset voltage (zero adjustment)

To compensate for offset voltage which is created

by the sensor and operational amplifier, measure the offset voltage (V0) in clean air (0ppm of CO) and write this value into an EEPROM or microprocessor. This value should be read from the finished detector (i.e. after installation of sensor, op-amp, etc.).

To obtain higher accuracy, keep ambient temperature in a range of $20 \pm 10^\circ\text{C}$ and be sure that the ambient air is completely free of CO.

6-3 Temperature compensation

It is necessary to continuously write the thermistor output into the microprocessor. Inside the microprocessor, temperature compensation is carried out by using the compensation coefficient table shown in Appendix 2. CO sensitivity at 20°C (α) is calculated by the following equation:

$$\alpha = \alpha t / CF$$

where:

CF = compensation coefficient at $t^\circ\text{C}$

αt = CO sensitivity at $t^\circ\text{C}$

6-4 Calculation of CO concentration

CO concentration (C) can be calculated by using sensor output (Vout), sensor output in clean air (V0), CO sensitivity at 20°C (α), and feedback resistor (Rf) in the following formula:

$$C = (V0 - Vout) / (\alpha \times Rf) \quad [Equation 1]$$

When high accuracy is required, temperature dependency of an op-amp should be considered.

7. Manufacturing Process (Fig. 8)

7-1 Handling and Storage of Sensors

Prior to usage, sensors should be stored in Figaro's original sealed bag under conditions of $5 \sim 30^\circ\text{C} / 30 \sim 80\% \text{RH}$. Dew condensation should be avoided. Sensors should be stored for a maximum period of 6 months. Sensors with a water reservoir (TGS5042) should NOT be stored in a moisture-proof bag (such as an aluminum coated bag) to prevent dew condensation.

7-2 PCB assembly

Flux should be sufficiently dried before sensors are assembled onto a PCB to avoid any contamination of the sensor by flux vapor

7-3 Sensor assembly

The sensor is shipped from Figaro in an open circuit condition, causing sensor polarization. As a result, the sensor requires a period during which it is shorted in order to remove the effects of polarization (please refer to Sec. 2-4 for more detail).

All models can be directly soldered onto a PCB. Recommended conditions for manual soldering:

- Temperature of soldering copper head: 360°C
- Period: < 5 sec.

Figaro has confirmed that wave soldering can be done without adverse effect by using the materials shown in Table 2. When different materials will be used, a test should be conducted before production starts to see if there would be any influence on sensor characteristics.

7-4 Final assembly

Avoid any shock or vibration which may be caused by air driven tools. This may cause breakage of the sensor's lead wires or other physical damage to the sensor.

7-5 Gas test

Test all finished products in the target gas under normal operating conditions. Keep the atmospheric conditions in the chamber stable, utilizing a user-defined standard test condition which is based on applicable performance standards and on anticipated usage for detectors. Remove any traces of smoke, adhesives, gases, or solvents from the chamber.

Do NOT use Nitrogen balanced CO gas. Oxygen molecules are required for the reaction of the sensor with CO (refer to Sec. 2-Operation Principle of Technical Info for TGS5042 and TGS5141). If exposed to a mixture of CO and N₂, the sensor reacts to CO by consuming oxygen molecules inside the

sensor. After consuming all the oxygen molecules inside sensor, the sensor will not react to CO.

Dry/bottled CO gas can be used since the sensor's humidity dependency is very small.

NOTE: Without testing after final assembly, detectors have no guarantee of accuracy or reliability.

7-6 Storage of finished products

Detectors should be stored in a clean air environment at room temperature. Storage in dirty or contaminated environments should be avoided. Also, avoid storage in extremely low humidity--sensor life may be shortened. Please refer to Sec. 6-Cautions in Technical Info for TGS5042 and TGS5141 for additional information.

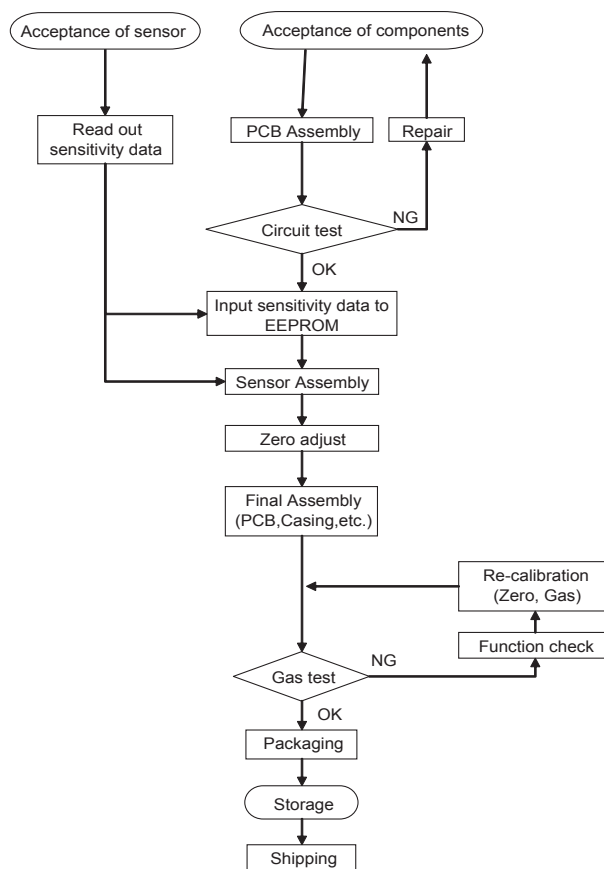

Figure 8 - Manufacturing flow chart

APPLICATION NOTES FOR TGS5xxx SERIES

No.	Soldering Material				Flux	
	Company	Model	Composition	Melting Temp	Company	Model
1	Solder Coat Co. Ltd.	LLS 219	Sn/3.0Ag/0.5Cu	Soldus line: 217°C Liquidus line: 219°C	Koki Company Limited	JS-E-11
2	Nihon Genma Mfg. Co., Ltd.	NO303T H B20	Sn/3.0Ag	Soldus line: 221°C Liquidus line: 223°C	Tamura Corporation	EC-19S-8
3	Koki Company Limited	S3X	Sn/3.0Ag/0.5Cu	Soldus line: 217°C Liquidus line: 219°C	Koki Company Limited	JS-E-15X

Table 2 - Wave soldering materials

7-7 Packaging

Never expose TGS5042 to a vacuum. Sudden exposure to a vacuum may temporarily damage the sensor. Be sure to follow the precautions detailed in *Sec. 5--Packaging Design*.

8. Quality Control

- 1) A sample of finished products from each production lot should be tested to confirm alarm concentration. Check whether these samples are acceptable for shipment and maintain a record of these tests.
- 2) Periodically sample a certain number of finished products to confirm the alarm concentration under extreme conditions (e.g. -10°C or 40°C/85%RH) and maintain a record of these tests.
- 3) Periodically sample a certain number of completed products to confirm their long-term characteristics and maintain a record of such tests.

9. Frequently Asked Questions

Q: What approvals do Figaro CO sensors have?

A: All TGS5xxx series sensors have received UL2034 component recognition.

Q: Is it true that long term stability of two-electrode electrochemical CO sensors is less than that of three electrode type sensors?

A: While this may be true for sensors whose electrode potentials are unstable, Figaro CO sensors exhibit good accuracy. With an optimized sensor structure and electrodes, the sensors maintain very stable electrode potentials. As a result, the sensor shows excellent long term stability.

Q: Where does CO gas enter into the sensor?

A: There are three pin holes in the working electrode which act as a gas inlet. Refer to Fig.1 on page 2 of *TGS5042/5141 Technical Information*.

Q: How long does it take to stabilize sensor output after storage when the sensor electrodes are open circuited?

A: The stabilization period depends on the degree of polarization. For example, if sensors are exposed to 100ppm CO for 10 min. while in open circuit condition, when using a JFET for anti-polarization, it takes about 5 min. of short circuit condition to discharge the sensor short.

In case of using a fixed resistor for anti-polarization, depending on the resistor's value, the stabilization period will vary. It is recommended to monitor sensor output within the actual circuit for stabilization, since the time required depends on stabilization period for both the CO sensor as well as the circuit itself.

Before purchasing this product, please read the Warranty Statements shown in our webpage by scanning this QR code.



https://www.figaro.co.jp/en/pdf/Limited_Warranty_en.pdf

FIGARO ENGINEERING INC.
1-5-11 Senba-nishi
Mino, Osaka 562-8505 JAPAN
Phone: (81)-727-28-2045
URL: www.figaro.co.jp/en/

Appendix 1 - Sensor Marking

Sensor	Marking
<p>Two dimensional bar code One dimensional bar code</p> <p>Lot No. Sensitivity to CO (nA/ppm) (Ex. 1911 - 1.911nA/ppm)</p>	<ol style="list-style-type: none"> One dimensional bar code (<i>see Note 1</i>) Two dimensional bar code (<i>see Note 2</i>) User readable format <ul style="list-style-type: none"> * 6-digit Lot Number is printed below the two dimensional bar code * Sensitivity per ppm (nA) is printed below the one dimensional bar code (e.g. 1827=1.827nA/ppm)
<p>Two-dimensional bar code</p>	<ol style="list-style-type: none"> Two-dimensional bar code (<i>see Note 2</i>)

Note 1: The one dimensional bar code indicates the sensor's sensitivity (slope) in numeric value as determined by measuring the sensor's output in 300ppm of CO:

$$xxxx = x.xxx \text{ nA/ppm}$$

Note 2: The two-dimensional bar code indicates:

xxxxxxxxxxxxxxxxxxxxxxxxxxxxxxxx

where:

xxxx = sensor's sensitivity (slope) in numeric value by measuring sensor output in CO 300ppm
(e.g. 1827=1.827nA/ppm)

xxxxxxxxxxxxxxxxxxxxxxxxxxxxxxxx = 24-digit manufacturer's serial number

Example barcode readers:

TGS5042: KEYENCE: SR-D100H

TGS5141:

KEYENCE: SR-G100, SR-1000,

SIEMENS: MV320, MV325, MV440

DATALOGIC: PowerScan 9500 DPM

Smart phone application:

i-nigma (iPhone)

Barcode Scanner (Android)

Appendix 2 - Temperature Compensation Coefficients for Residential Usage

Temp (°C)	CF (l/lo)		Temp (°C)	CF (l/lo)	
	TGS5042	TGS5141-P00		TGS5042	TGS5141-P00
-10	0.752	0.6745	30	1.060	1.0750
-9	0.761	0.6854	31	1.066	1.0825
-8	0.771	0.6963	32	1.071	1.0900
-7	0.780	0.7072	33	1.076	1.0975
-6	0.789	0.7181	34	1.080	1.1050
-5	0.799	0.7290	35	1.085	1.1125
-4	0.808	0.7399	36	1.089	1.1200
-3	0.817	0.7508	37	1.094	1.1275
-2	0.826	0.7617	38	1.098	1.1350
-1	0.835	0.7726	39	1.101	1.1425
0	0.844	0.7835	40	1.105	1.1500
1	0.852	0.7944	41	1.109	1.1575
2	0.861	0.8053	42	1.112	1.1650
3	0.870	0.8162	43	1.115	1.1725
4	0.878	0.8271	44	1.118	1.1800
5	0.887	0.8380	45	1.121	1.1875
6	0.895	0.8489	46	1.124	1.1950
7	0.903	0.8598	47	1.126	1.2025
8	0.911	0.8707	48	1.128	1.2100
9	0.919	0.8816	49	1.130	1.2175
10	0.927	0.8925	50	1.132	1.2250
11	0.935	0.9034	51	1.134	-
12	0.943	0.9143	52	1.135	-
13	0.950	0.9252	53	1.136	-
14	0.958	0.9361	54	1.137	-
15	0.965	0.9470	55	1.138	-
16	0.972	0.9579			
17	0.980	0.9688			
18	0.987	0.9797			
19	0.994	0.9906			
20	1.000	1.0000			
21	1.007	1.0075			
22	1.013	1.0150			
23	1.020	1.0225			
24	1.026	1.0300			
25	1.032	1.0375			
26	1.038	1.0450			
27	1.044	1.0525			
28	1.050	1.0600			
29	1.055	1.0675			

Appendix 3 - Temperature Compensation Coefficients for Portable Generators

Temp (°C)	CF (l/l _o)	Temp (°C)	CF (l/l _o)	Temp (°C)	CF (l/l _o)
	TGS5141-NP0/PP0		TGS5141-NP0/PP0		TGS5141-NP0/PP0
-40	0.1589	0	0.7835	40	1.1500
-39	0.1761	1	0.7944	41	1.1575
-38	0.1933	2	0.8053	42	1.1650
-37	0.2105	3	0.8162	43	1.1725
-36	0.2277	4	0.8271	44	1.1800
-35	0.2448	5	0.8380	45	1.1875
-34	0.2620	6	0.8489	46	1.1950
-33	0.2792	7	0.8598	47	1.2025
-32	0.2964	8	0.8707	48	1.2100
-31	0.3136	9	0.8816	49	1.2175
-30	0.3308	10	0.8925	50	1.2250
-29	0.3479	11	0.9034	51	1.2271
-28	0.3651	12	0.9143	52	1.2292
-27	0.3823	13	0.9252	53	1.2313
-26	0.3995	14	0.9361	54	1.2334
-25	0.4167	15	0.9470	55	1.2355
-24	0.4339	16	0.9579	56	1.2376
-23	0.4510	17	0.9688	57	1.2396
-22	0.4682	18	0.9797	58	1.2417
-21	0.4854	19	0.9906	59	1.2438
-20	0.5026	20	1.0000	60	1.2459
-19	0.5198	21	1.0075	61	1.2516
-18	0.5370	22	1.0150	62	1.2574
-17	0.5542	23	1.0225	63	1.2632
-16	0.5713	24	1.0300	64	1.2690
-15	0.5885	25	1.0375	65	1.2748
-14	0.6057	26	1.0450	66	1.2806
-13	0.6229	27	1.0525	67	1.2864
-12	0.6401	28	1.0600	68	1.2922
-11	0.6573	29	1.0675	69	1.2980
-10	0.6745	30	1.0750	70	1.3038
-9	0.6854	31	1.0825		
-8	0.6963	32	1.0900		
-7	0.7072	33	1.0975		
-6	0.7181	34	1.1050		
-5	0.7290	35	1.1125		
-4	0.7399	36	1.1200		
-3	0.7508	37	1.1275		
-2	0.7617	38	1.1350		
-1	0.7726	39	1.1425		